

### APPLICATIONS

- Sewage and effluent wastewater transfer • Dewatering

### FEATURES

- Permanent Split Capacitor (PSC)
- Designed for continuous duty
- 2" FNPT (51 mm) and 3" FNPT (76.2 mm) discharge models
- Handles solids up to 2" (51 mm) diameter
- 140 °F (60 °C) liquid temperature rating
- cCSAus listed



### SERIES SPECIFICATIONS

Volts	Hz	Amps		Watts	Performance (GPM @ Height in Feet)		Shut-Off (ft)	PSI
		FLA	Start		10'	20'		
115	60	11.6	21	1100	100	35	25	10.8
208-240	60	4.6	7.8	1100	100	35	25	10.8

Item No.	Model	HP	Volts	Discharge	Switch Type/ Operation	Cord	Weight
514320	14S-CIM	1/2	115	2"	Manual	20' 6.1 m	87 lbs 39.46 Kg
514420	14S-CIM*	1/2	115	3"	Manual	20' 6.1 m	88 lbs 39.92 Kg
514321	14S-CIM	1/2	208 -240	2"	Manual	20' 6.1 m	88 lbs 39.92 Kg
14940726	14S-CIM*	1/2	208 - 240	3"	Manual	20' 6.1 m	88 lbs 39.92 Kg

ENGINEERING DATA

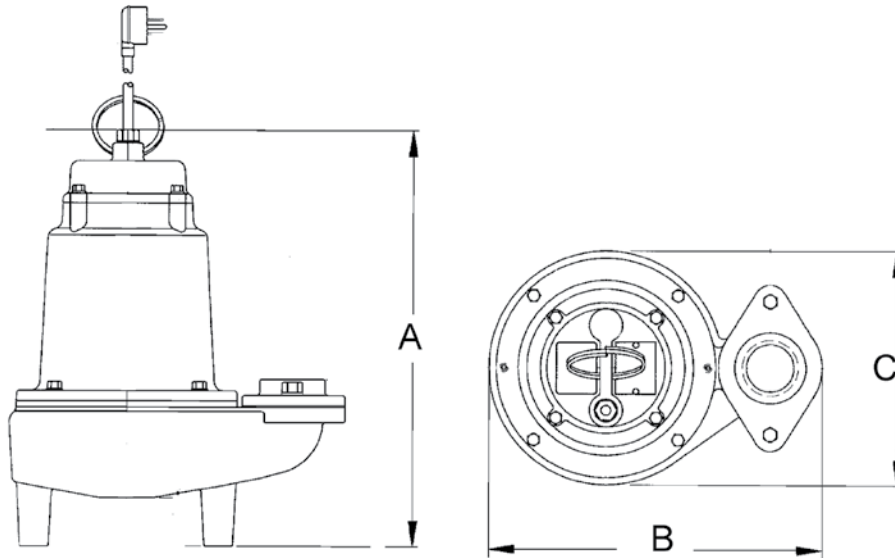

A	B	C
16.15" 41.02 cm	14.07" 35.74 cm	9.89" 25.12 cm

PERFORMANCE DATA

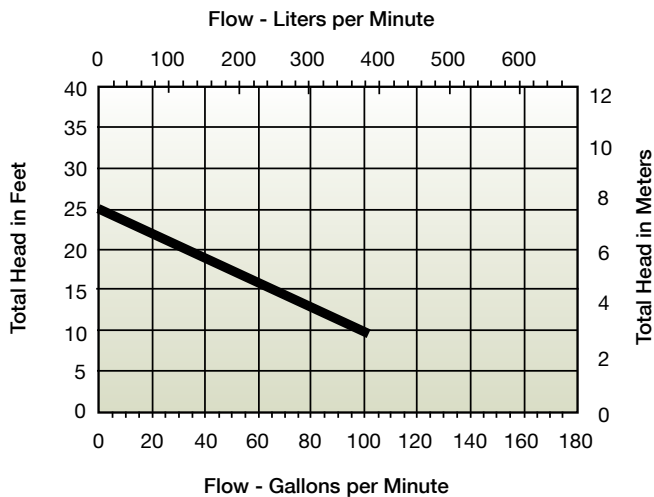

CONSTRUCTION

<b>Motor Housing</b>	Epoxy-coated cast iron
<b>Impeller Material</b>	Epoxy-coated cast iron
<b>Impeller Type</b>	Two-vane, non-clog
<b>Volute</b>	Epoxy-coated cast iron
<b>Mechanical Shaft Seal</b>	Nitrile with carbon and ceramic faces
<b>Fasteners</b>	Stainless steel
<b>Shaft</b>	Stainless steel
<b>Bearings</b>	Upper and lower ball bearings
<b>Power Cord</b>	16/3, STW