High Temp Sump Pump

INSTALLATION, OPERATION AND MAINTENANCE INSTRUCTIONS

TABLE OF CONTENTS

SUBJECT	PAGE
Introduction	3
Safety Instructions	3
Performance and Motor Details.....	3
Pre-Installation Checks	3
Lifting of Pump	4
Optional Guide Rail or Lift-Out System	4
Piping.....	4
Wiring and Grounding	4
Selecting and Wiring Pump Control Panels and Switches	4
Installation	5
Operation.....	5
Float Switch and Panel Chart.....	6
Insulation Resistance Readings	7
Engineering Data.....	7
Troubleshooting	8
Typical Installations	9
Limited Warranty	12

Owner's Information

Pump Model Number: _____

Pump Serial Number: _____

Control Model Number: _____

Dealer: _____

Dealer Phone No. _____

Date of Purchase: _____ Installation: _____

Current Readings at Startup:

1Ø	3Ø	L1-2	L2-3	L3-1
Amps: _____	Amps: _____	_____	_____	_____
Volts: _____	Volts: _____	_____	_____	_____

INTRODUCTION

Goulds Water Technology High Temperature 3885 Series Effluent pumps are recommended for use in High Temperature applications up to 200°F. The High Temperature 3885 Pump handles 3/4" solids. Common applications include boiler blow down and High Temperature condensate. Pump should be operated with a High Temperature float switch sold separately.

SAFETY INSTRUCTIONS

TO AVOID SERIOUS OR FATAL PERSONAL INJURY OR MAJOR PROPERTY DAMAGE, READ AND FOLLOW ALL SAFETY INSTRUCTIONS IN MANUAL AND ON PUMP.

THIS MANUAL IS INTENDED TO ASSIST IN THE INSTALLATION AND OPERATION OF THIS UNIT AND MUST BE KEPT WITH THE PUMP.



This is a SAFETY ALERT SYMBOL. When you see this symbol on the pump or in the manual, look for one of the following signal words and be alert to the potential for personal injury or property damage.

⚠ DANGER Warns of hazards that **WILL** cause serious personal injury, death or major property damage.

⚠ WARNING Warns of hazards that **CAN** cause serious personal injury, death or major property damage.

⚠ CAUTION Warns of hazards that **CAN** cause personal injury or property damage.

NOTICE: INDICATES SPECIAL INSTRUCTIONS WHICH ARE VERY IMPORTANT AND MUST BE FOLLOWED.

THOROUGHLY REVIEW ALL INSTRUCTIONS AND WARNINGS PRIOR TO PERFORMING ANY WORK ON THIS PUMP.

MAINTAIN ALL SAFETY DECALS.

⚠ WARNING All electrical work must be performed by a qualified technician. Always follow the National Electrical Code (NEC), or the Canadian Electrical Code, as well as all local, state and provincial codes. Code questions should be directed to your local electrical inspector. Failure to follow electrical codes and OSHA safety standards may result in personal injury or equipment damage. Failure to follow manufacturer's installation instructions may result in electrical shock, fire hazard, personal injury or death, damaged equipment, provide unsatisfactory performance, and may void manufacturer's warranty.

MODELS

Order Number	HP	Phase	Volts	RPM	Impeller Dia. (In.)	Max. Amps	LRA	KVA Code	Full Load Motor Eff.	Resistance		Wt. (Lbs.)	Cord Length
										Start	Line-Line		
WEHT0311M	0.33	1	115	1750	5.38	12.0	31.1	J	55	9.3	1.4	56	20'
WEHT0318M			208			7.3	19.5	K	51	9.1	4.2		
WEHT0312M			230			6.1	16.5	J	54	11.7	5.6		

*Add P1 to the end of the order number to include an ultra hi-temp float switch in the purchase.

Replacement part numbers for float: A2HT31 - 115V and A2HT32 - 208 and 230V (20' cord length).

⚠ WARNING Standard units are not designed for use in swimming pools, open bodies of water, hazardous liquids, or where flammable gases exist. These fluids and gases may be present in containment areas. Tank or wetwell must be vented per local codes.

Only pumps specifically Listed for Class 1, Division 1 are allowable in hazardous liquids and where flammable gases may exist. *See specific pump catalog bulletins or pump nameplate for all agency Listings.*

⚠ WARNING Disconnect and lockout electrical power before installing or servicing any electrical equipment. Many pumps are equipped with automatic thermal overload protection which may allow an overheated pump to restart unexpectedly.

⚠ WARNING Do not use pump flammable or explosive liquids. Pump is for water only.

PERFORMANCE

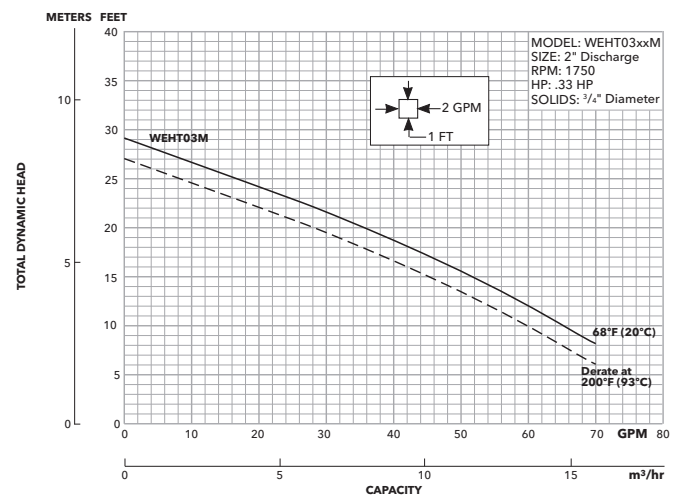

PRE-INSTALLATION CHECKS

Open all cartons and inspect for shipping damage. Report any damage to your supplier or shipping carrier immediately.

Important: Always verify that the pump nameplate Amps, Voltage, Phase and HP ratings match your control panel and power supply.

This pump is oil-filled. If there are any signs of oil leakage or if the unit has been stored for an extended period check the oil level in the motor dome and the seal housing, if so equipped.

Check the motor cover oil level through the pipe plug on top of the unit. The motor chamber oil should just cover the motor. Do not overfill, leave room for expansion!

To check the seal housing oil level, where used, lay the unit on its side with the fill plug at 12 o'clock. Remove the plug. The oil should be within ½" (13mm) of the top. If low, refill with an ASTM 150 turbine oil. Replace the plug.

Oil is available in 5 gallon cans through our distributors. You can also source oil locally at motor repair shops.

Typical oil brands are: Shell Turbo 32, Sunoco Sunvis 932, Texaco Regal R&O 32, Exxon Nuto 32 and Mobil DTE Light.

Check the strain relief nut on power cable strain assemblies. Power cables should be torqued to 75 in. lbs., cable supplied is for high temp use.

Warranty does not cover damage caused by connecting pumps and controls to an incorrect power source (voltage/phase supply).

Record the model numbers and serial numbers from the pumps and control panel on the front of this instruction manual for future reference. Give it to the owner or affix it to the control panel when finished with the installation.

FOR ALL SES PUMP INSTALLATIONS

LIFTING OF PUMP



DO NOT LIFT, CARRY OR HANG PUMP BY THE ELECTRICAL CABLES. DAMAGE TO THE ELECTRICAL CABLES CAN CAUSE SHOCK, BURNS OR DEATH.

Lift the pump with an adequately sized chain or cable attached to the lifting eye bolt. **DO NOT** damage electrical cables while raising and lowering unit.

OPTIONAL GUIDE RAIL OR LIFT-OUT SYSTEM

In many effluent and sewage basins or lift stations it is advisable to install the pump on a guide rail system or on a lift-out adapter to facilitate installation and removal for inspection and/or service. Most codes do not allow personnel to enter a wetwell without the correct protective equipment and training. Guide rails are designed to allow easy removal of the pump without the need for entry into the wetwell or need to disturb piping. The guide rail or lift-out adapter should locate the pump opposite the influent opening preventing stagnate areas where solids can settle. The basin or pit must be capable of supporting the weight of the pump and guide rail. The pit floor must be flat.

NOTICE: FOLLOW THE INSTRUCTIONS THAT ARE PROVIDED WITH THE GUIDE RAIL ASSEMBLY.

PIPING

Discharge piping should be no smaller than the pump discharge diameter and kept as short as possible, avoiding unnecessary fittings to minimize friction losses. Piping should be rated for high temperatures if used in high temperature applications.

Install an adequately sized check valve matched to the solids handling capability of the pump to prevent fluid backflow. Backflow can allow the pump to "turbine"

backwards and may cause premature seal and/or bearing wear. If the pump is turning backwards when it is called on to start the increased torque may cause damage to the pump motor and/or motor shaft and some single-phase pumps may actually run backwards.

Install an adequately sized gate valve **AFTER** the check valve for pump, plumbing and check valve maintenance.







Important – Before pump installation. Drill a 3/16" (4.8mm) relief hole in the discharge pipe. It should be located within the wetwell, 2" (51mm) above the pump discharge but below the check valve. The relief hole allows any air to escape from the casing. Allowing liquid into the casing will insure that the pump can start when the liquid level rises. Unless a relief hole is provided, a bottom intake pump could "air lock" and will not pump water even though the impeller turns.

All piping must be adequately supported, so as not to impart any piping strain or loads on the pump.

The pit access cover must be of sufficient size to allow for inspection, maintenance and crane or hoist service.

WIRING AND GROUNDING

Important notice: Read Safety Instructions before proceeding with any wiring.

-  Use only stranded copper wire to pump/motor and ground. The ground wire must be at least as large as the power supply wires. Wires should be color coded for ease of maintenance and troubleshooting.
-  Install wire and ground according to the National Electrical Code (NEC), or the Canadian Electrical Code, as well as all local, state and provincial codes.
-  Install an all leg disconnect switch where required by code.
-  Disconnect and lockout electrical power before performing any service or installation.
-  The electrical supply voltage and phase must match all equipment requirements. Incorrect voltage or phase can cause fire, motor and control damage, and voids the warranty.
-  All splices must be waterproof. If using splice kits follow manufacturer's instructions.

 **WARNING** Select the correct type and NEMA grade junction box for the application and location. The junction box must insure dry, safe wiring connections.

 **WARNING** Seal all controls from gases present which may damage electrical components.

 **WARNING** **Hazardous voltage**
FAILURE TO PERMANENTLY GROUND THE PUMP, MOTOR AND CONTROLS BEFORE CONNECTING TO POWER CAN CAUSE SHOCK, BURNS OR DEATH.

SELECTING AND WIRING PUMP CONTROL PANELS AND SWITCHES

FLOAT SWITCH TYPES

High Temp floats can be purchased for High Temp applications. They are normally open (NO) for pump down operations.

These wide-angle, pump down switches may be used as direct connected pump switches or as control switches.

SETTING THE FLOAT SWITCHES

There are no absolute rules for where to set the float switches, it varies from job to job.

Suggested Rules to Follow:

All floats should be set below the Inlet pipe!

Off Float: Best: set so the water level is always above the top of the pump (motor dome). **Next Best:** set so the water level is not more than 6" below the top of the pump.

On Float: set so the volume of water between the On and Off floats allows pumps of 1½ HP and under to operate for 1 minute minimum. Two (2) HP and larger pumps should run a minimum of 2 minutes. Basin literature states the gallons of storage per inch of basin height.

Lag/Alarm Float(s): should be staggered above the Off and On floats. Try to use most of the available storage provided by the basin, save some space for reserve storage capacity. *See Diagrams and Charts in Float Switch Chart Section.*

PANEL WIRING DIAGRAMS

Our control panels are shipped with instructions and wiring diagrams. Use those instructions in conjunction with this IOM. Electrical installation should be performed only by qualified technicians. Any problem or questions pertaining to another brand control must be referred to that control supplier or manufacturer. Our technical people have no technical schematics or trouble shooting information for other companies' controls.

ALARMS

We recommend the installation of an alarm on all Wastewater pump installations. Many standard control panels come equipped with alarm circuits. If a control panel is not used, a stand alone high liquid level alarm is available. The alarm alerts the owner of a high liquid level in the system so they can contact the appropriate service personnel to investigate the situation.

SINGLE PHASE PUMPS

Single phase (1Ø) pumps may be operated using a piggyback or hard wired float switch, a contactor, or a Simplex or Duplex control panel. *See Figures 1 and 4.*

All 1/3 and 1/2 HP, 115 or 230 volt pumps, and some 3/4 and 1 HP pumps, are supplied with plug style power cords. They may be plugged into piggyback float switches for simple installations. It is allowable to remove the plugs in order to hardwire or connect to a Simplex or Duplex controller. Removing the plug neither voids the warranty nor violates the agency Listings. *See Figure 4.*



PLUG-CONNECTED UNITS MUST BE CONNECTED TO A PROPERLY GROUNDED, GROUNDING TYPE RECEPTACLE.

ON NON-PLUG UNITS, DO NOT REMOVE CORD AND STRAIN RELIEF. DO NOT CONNECT CONDUIT TO PUMP.

Pumps with bare lead power cords can be hard-wired to a float switch, wired to a 1Ø contactor, a Simplex controller or a Duplex controller. Always verify that the float switch is rated for the maximum run amperage, maximum starting amperage, and the HP rating on the pump. Single-phase

wastewater pumps contain on-winding overloads, unless noted on the pump nameplate. *See Figure 1.*

SINGLE PHASE CONTROL PANELS:

Control panels are available as Simplex (controls 1 pump) or Duplex (controls 2 pumps). Our standard SES Series Panels are available with many standard features and can be built with our most popular options. We also custom build panels which offer many more design options than the SES panels. Custom control panels are available in many different configurations. Custom panel quote requests may be forwarded to Customer Service through any authorized distributor.

Our "SES" Duplex panels feature a solid-state printed circuit board design with standard high level alarm circuits. Other standard features are: an auxiliary dry alarm contact for signaling a remote alarm and float switch position indicator lights.

INSTALLATION

Connect the pump(s) to the guide rail pump adapters or to the discharge piping. Slide rail bases should be anchored to the wetwell floor.

Complete all wiring per the control panel wiring diagrams and NEC, Canadian, state, provincial and/or local codes. This a good time to check for proper rotation of the motors/impellers.



DO NOT PLACE HANDS IN PUMP SUCTION WHILE CHECKING MOTOR ROTATION. TO DO SO WILL CAUSE SEVERE PERSONAL INJURY.

Always verify correct rotation. Correct rotation is indicated on the pump casing. Three phase motors are reversible. It is allowable to bump or jog the motor for a few seconds to check impeller rotation. It is easier to check rotation before installing the pump. Switch any two power leads to reverse rotation.

Lower the pump(s) into the wetwell.

Check to insure that the floats will operate freely and not contact the piping.

OPERATION

Once the piping connections are made and checked you can run the pumps.

Piggyback Switch Operation – Plug the piggyback switch into a dedicated grounded outlet and then plug the pump into the switch. Test the pump by filling the wetwell until the pump goes On. If the pumps run but fail to pump, they are probably air locked, drill the relief holes per the instructions in the Piping Section.

Check the operating range to insure a minimum one minute run time and that the pump goes Off in the correct position.

Control Panel Operation – Fill the wetwell with clear water.

Use the pump H-O-A (Hand-Off-Automatic) switches in Hand to test the pumps. If they operate well in Hand proceed to test Automatic operation. If the pumps run but fail to pump, they are probably air locked, drill the relief holes per the instructions in the Piping Section.

Place Control Panel switch(es) in Automatic position and thoroughly test the operation of the ON, OFF, and Alarm floats by filling the wetwell with clear water. **Important:** Failure to provide a Neutral from the power supply to a 1Ø, 230 volt Control Panel will not allow the panel control circuit to operate. The Neutral is necessary to complete the 115 volt control circuit.

Check voltage and amperage and record the data on the front of this manual for future reference. Compare the amperage readings to the pump nameplate maximum amperage. If higher than nameplate amperage investigate cause. Operating the pump off the curve, i.e. with too little head or with high or low voltage will increase amperage. The motor will operate properly with voltage not more than

10% above or below pump nameplate ratings. Performance within this range will not necessarily be the same as the published performance at the exact rated nameplate frequency and voltage. Correct the problem before proceeding. Three phase unbalance is also a possible cause. *See Three Phase Power Unbalance and follow the instructions.*

Reset the Alarm circuit, place pump switch(es) in the Automatic position and Control Switch in ON position. The system is now ready for automatic operation.

Explain the operation of the pumps, controls and alarms to the end user. Leave the paperwork with the owner or at the control panel if in a dry, secure location.

FLOAT SWITCH AND PANEL CHART

The purpose of this chart is to show the required switch quantities and the function of each switch in a typical wastewater system. The quantities required vary depending on the switch type, single-action or wide-angle. Switch quantities also vary by panel type: simplex with and without alarms, and duplex with alarms.

Duplex Panels using single-action switches:

Three Float Panel Wiring

SW1	Bottom	Pumps Off
SW2	Middle	1st Pump On
SW3	Top	2nd Pump & Alarm On

Four Float Panel Wiring ②

SW1	Bottom	Pumps Off
SW2	2nd	1st Pump On
SW3	3rd	2nd Pump On
SW4	Top	Alarm On

Duplex Panels using wide-angle switches:

Three Float Panel Wiring

SW1	Bottom	1st Pump On/Both Off
SW2	Top	2nd Pump & Alarm On

Four Float Panel Wiring

SW1	Bottom	1st Pump On/Both Off
SW2	Middle	2nd Pump On
SW3	Top	Alarm On

Simplex Panel using single-action switches:

Simplex Panel with Alarm ①

SW1	Bottom	Pump Off
SW2	Middle	Pump On
SW3	Top	Alarm On/Off

Simplex Panel with No Alarm

SW1	Bottom	Pump Off
SW2	Top	Pump On

Simplex Panel using wide-angle switches:

Simplex Panel with Alarm

SW1	Bottom	Pump On/Off
SW2	Top	Alarm On/Off

Simplex Panel with No Alarm

SW1	Pump On/Off
-----	-------------

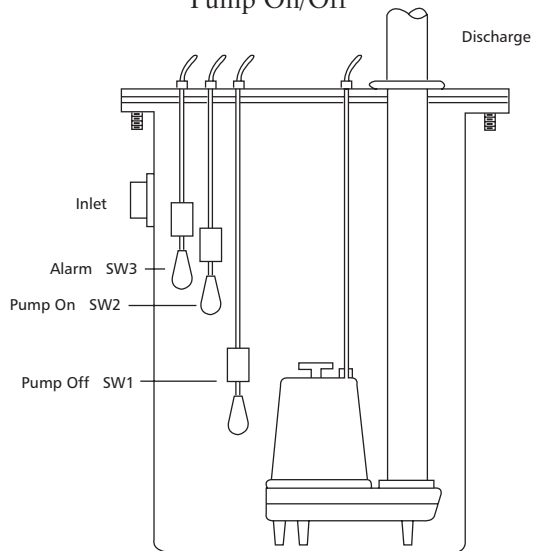

Simplex ①

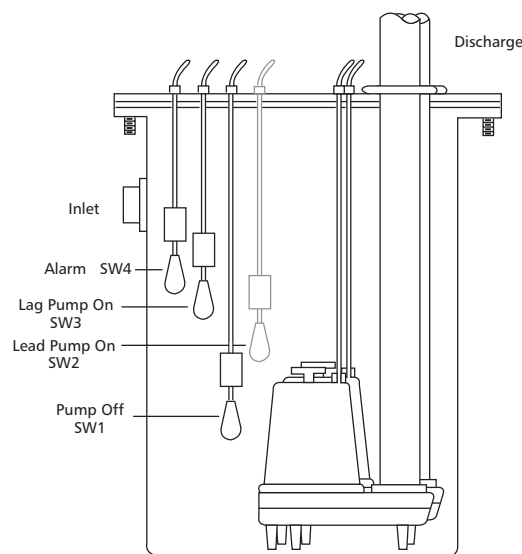

Duplex ②

INSULATION RESISTANCE READINGS

Normal Ohm and Megohm Values between all leads and ground

Condition of Motor and Leads	Ohm Value	Megohm Value
A new motor (without drop cable).	20,000,000 (or more)	20 (or more)
A used motor which can be reinstalled in well.	10,000,000 (or more)	10 (or more)
Motor in well. Readings are for drop cable plus		
New motor.	2,000,000 (or more)	2 (or more)
Motor in good condition.	500,000 - 2,000,000	.5 - 2
Insulation damage, locate and repair.	Less than 500,000	Less than .5

Insulation resistance varies very little with rating. Motors of all HP, voltage and phase ratings have similar values of insulation resistance.

Insulation resistance values above are based on readings taken with a megohmmeter with a 500V DC output. Readings may vary using a lower voltage ohmmeter, consult factory if readings are in question.

ENGINEERING DATA

Engineering data for specific models may be found in your catalog and on our website (address is on the cover).

Control panel wiring diagrams are shipped with the control panels. Please use the control panel drawings in conjunction with this instruction manual to complete the wiring.

PUMP OPERATION			
Minimum Submergence		Maximum Fluid Temperature	
Continuous Duty	Fully Submerged	Continuous Operation	200° F 93° C

Pumpmaster and Pumpmaster Plus - Hard Wired

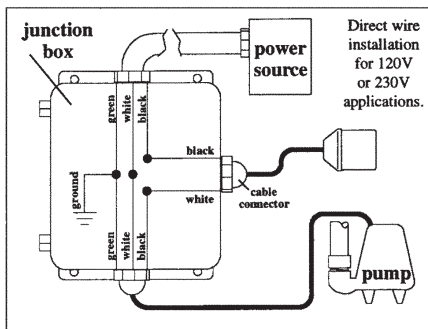

Figure 1

Single-Action Float Switch "Typical" Installation

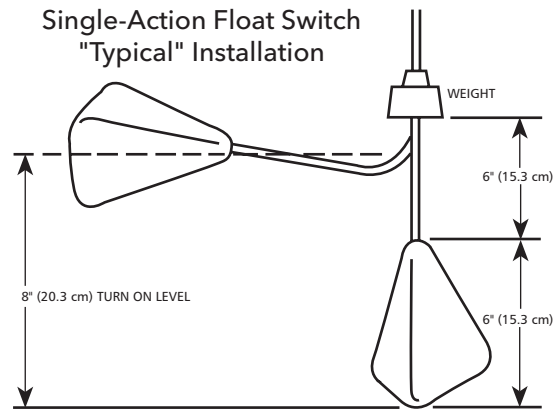

Figure 3

Determining Pumping Range

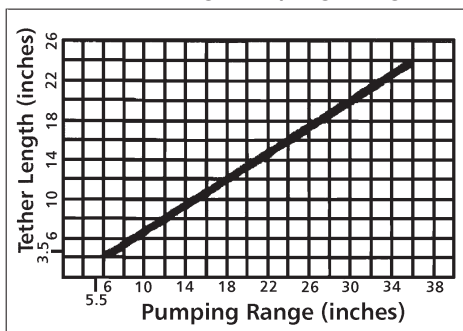

Figure 2

Wide-Angle Float Switch

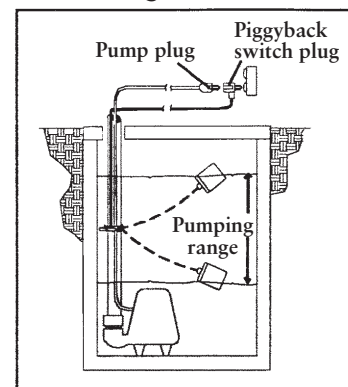

Figure 4

TROUBLESHOOTING



FAILURE TO DISCONNECT AND LOCKOUT ELECTRICAL POWER BEFORE ATTEMPTING ANY SERVICE CAN CAUSE SHOCK, BURNS OR DEATH.

SYMPTOM	PROBABLE CAUSE	RECOMMENDED ACTION
MOTOR NOT RUNNING NOTE: If circuit breaker "OPENS" repeatedly, DO NOT reset. Call qualified electrician. a) Manual operation b) Automatic operation NOTE: Check the pump in manual mode first to confirm operation. If pump operates, the automatic control or wiring is at fault. If pump does not operate, see above.	Motor thermal protector tripped.	Allow motor to cool. Insure minimum pump submergence. Clear debris from casing and impeller.
	Open circuit breaker or blown fuse. Pump impeller binding or jammed.	Determine cause, call a qualified electrician. Check motor amp draw. If two or more times higher than listed on pump nameplate, impeller is locked, motor bearings or shaft is damaged. Clear debris from casing and impeller, consult with dealer.
	Power cable is damaged. Inadequate electrical connection in control panel.	Resistance between power leads and ground should read infinity. If any reading is incorrect, call a qualified electrician. Inspect control panel wiring. Call a qualified electrician.
	Defective liquid level switch. Insufficient liquid level to activate controls. Liquid level cords tangled.	With switch disconnected, check continuity while activating liquid level switch. Replace switch, as required. Allow liquid level to rise 3" to 4" (76 mm - 101 mm) above turn-on level. Untangle cords and insure free operation.
PUMP WILL NOT TURN OFF	Liquid level cords tangled.	Untangle cords and insure free operation.
	Pump is air locked.	Shut off pump for approximately one minute, then restart. Repeat until air lock clears. If air locking persists in a system with a check valve, a $\frac{3}{16}$ " (4.8 mm) hole may be drilled in the discharge pipe approximately 2" (51 mm) above the discharge connection.
	Influent flow is matching pump's discharge capacity.	Larger pump may be required.
LITTLE OR NO LIQUID DELIVERED BY PUMP	Check valve installed backwards, plugged or stuck closed.	Check flow arrow on valve and check valve operation.
	Excessive system head.	Consult with dealer.
	Pump inlet plugged.	Inspect and clear as required.
	Improper voltage or wired incorrectly.	Check pump rotation, voltage and wiring. Consult with qualified electrician.
	Pump is air locked.	See recommended action, above.
	Impeller is worn or damaged. Liquid level controls defective or improperly positioned.	Inspect impeller, replace as required. Inspect, readjust or replace as required.
PUMP CYCLES CONSTANTLY	Discharge check valve inoperative.	Inspect, repair or replace as required.
	Sewage containment area too small.	Consult with dealer.
	Liquid level controls defective or improperly positioned.	Inspect, readjust or replace as required.
	Influent excessive for this size pump.	Consult with dealer.

TYPICAL INSTALLATIONS

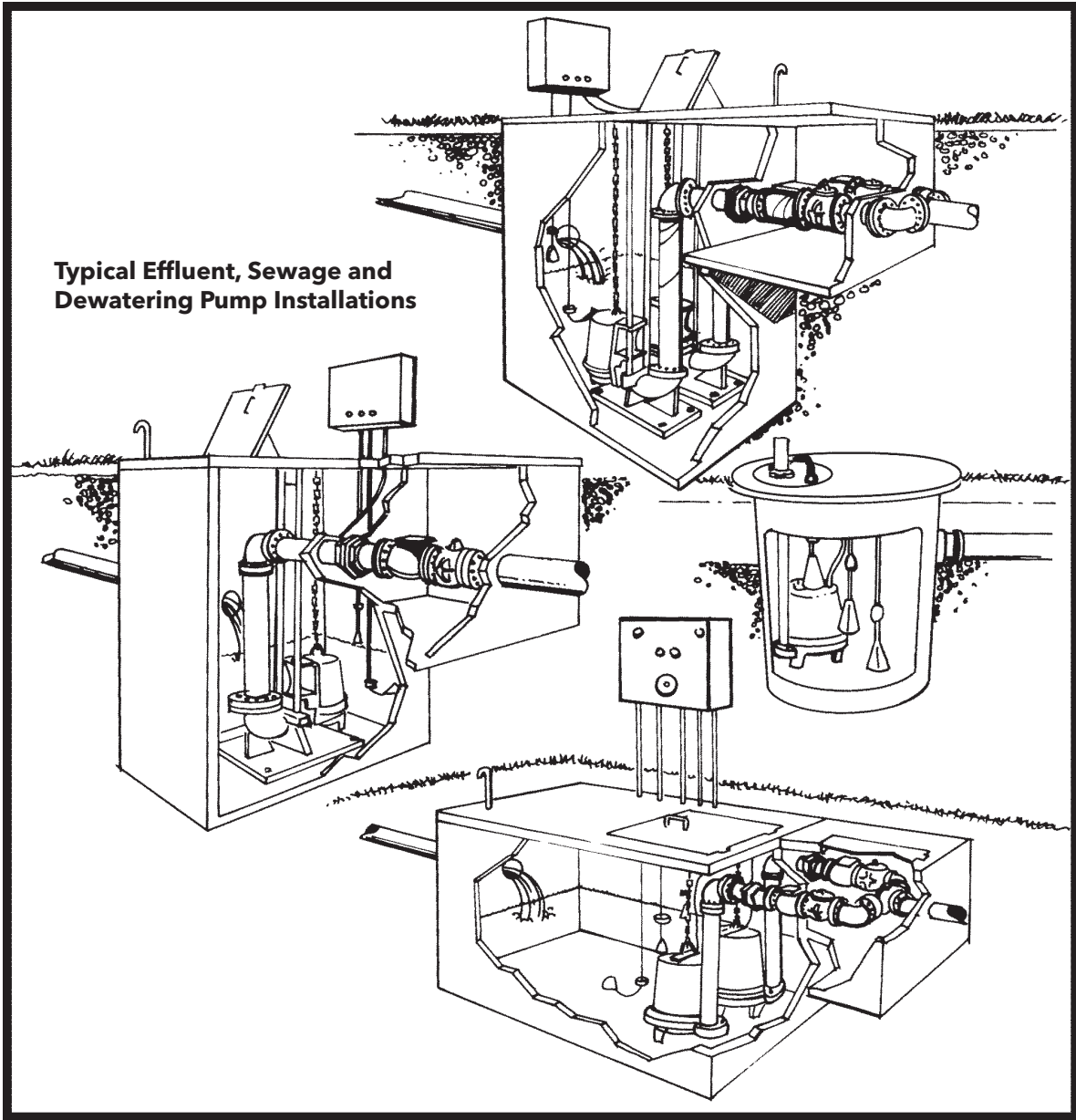

NOTES

GOULDS WATER TECHNOLOGY LIMITED WARRANTY

This warranty applies to all water systems pumps manufactured by Goulds Water Technology.

Any part or parts found to be defective within the warranty period shall be replaced at no charge to the dealer during the warranty period. The warranty period shall exist for a period of twelve (12) months from date of installation or eighteen (18) months from date of manufacture, whichever period is shorter.

A dealer who believes that a warranty claim exists must contact the authorized Goulds Water Technology distributor from whom the pump was purchased and furnish complete details regarding the claim. The distributor is authorized to adjust any warranty claims utilizing the Goulds Water Technology Customer Service Department.

The warranty excludes:

- (a) Labor, transportation and related costs incurred by the dealer;
- (b) Reinstallation costs of repaired equipment;
- (c) Reinstallation costs of replacement equipment;
- (d) Consequential damages of any kind; and,
- (e) Reimbursement for loss caused by interruption of service.

For purposes of this warranty, the following terms have these definitions:

- (1) "Distributor" means any individual, partnership, corporation, association, or other legal relationship that stands between Goulds Water Technology and the dealer in purchases, consignments or contracts for sale of the subject pumps.
- (2) "Dealer" means any individual, partnership, corporation, association, or other legal relationship which engages in the business of selling or leasing pumps to customers.
- (3) "Customer" means any entity who buys or leases the subject pumps from a dealer. The "customer" may mean an individual, partnership, corporation, limited liability company, association or other legal entity which may engage in any type of business.

THIS WARRANTY EXTENDS TO THE DEALER ONLY.



Xylem, Inc.
2881 East Bayard Street Ext., Suite A
Seneca Falls, NY 13148
Phone: (866) 325-4210
Fax: (888) 322-5877
www.xylem.com/brands/gouldswatertechnology

Goulds is a registered trademark of Goulds Pumps, Inc. and is used under license.
© 2012 Xylem Inc. IM248 Revision Number 1 July 2012