

Installation, Operation and Maintenance Manual

Please read and save these instructions for future reference. Read carefully before attempting to assemble, install, operate or maintain the product described. Protect yourself and others by observing all safety information. Failure to comply with instructions could result in personal injury and/or property damage!

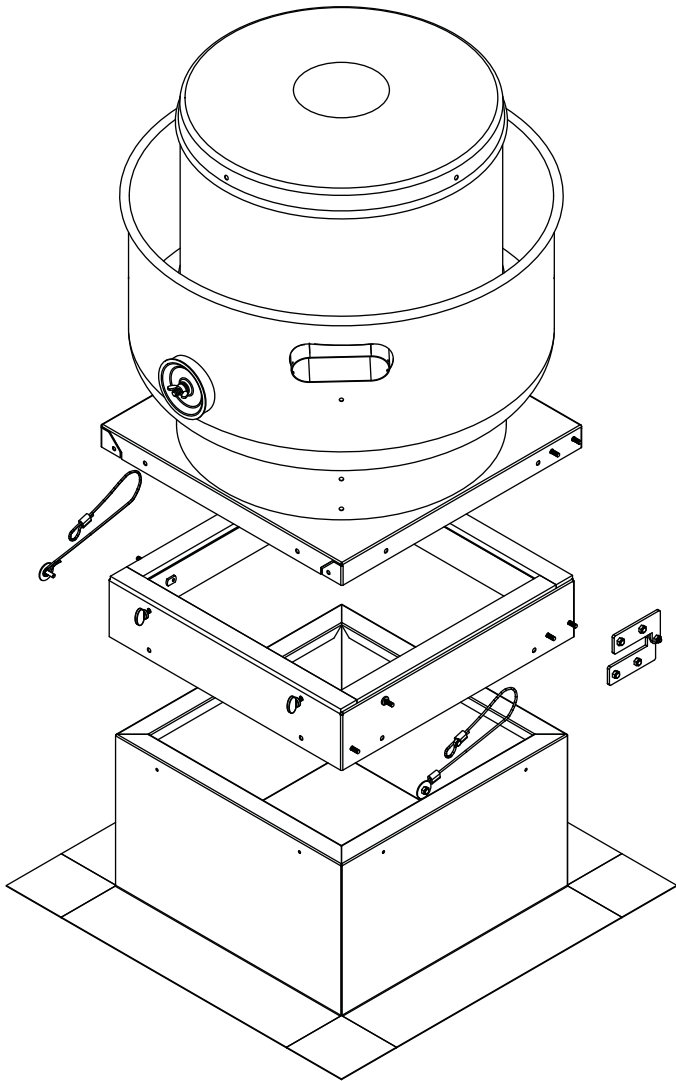

WARNING

Disconnect power and observe proper lock out tag out procedures per OSHA regulation (Title 29 code of federal regulations part 1910.147 & 1910.333).

Note: If fan is connected to electrical source via rigid connection, a qualified electrician will need to change the rigid connection to a flexible connection long enough per local electrical codes to allow for fan movement.

FIGURE 1

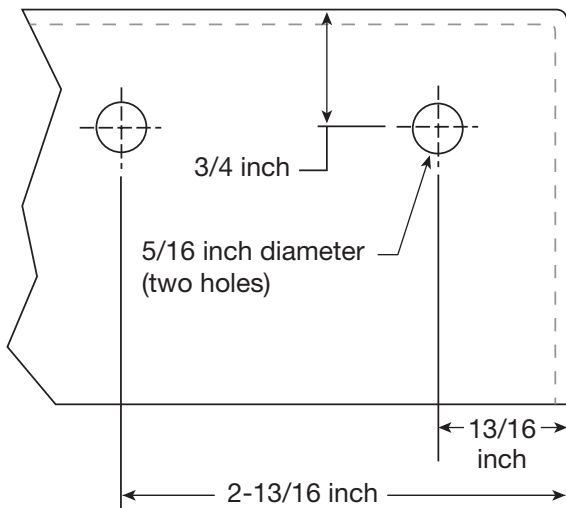

FIGURE 2

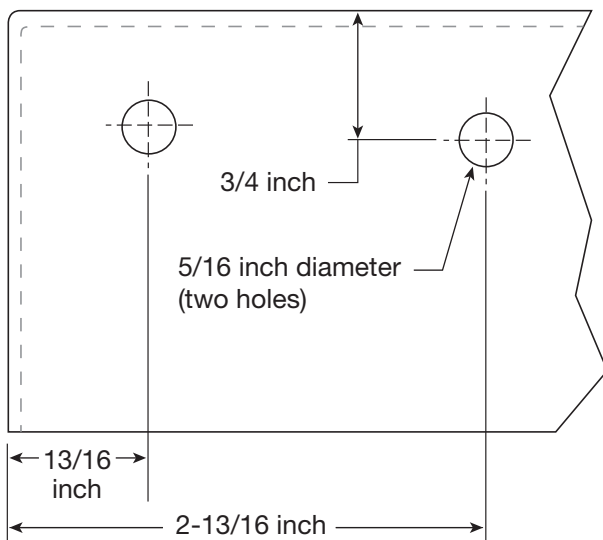
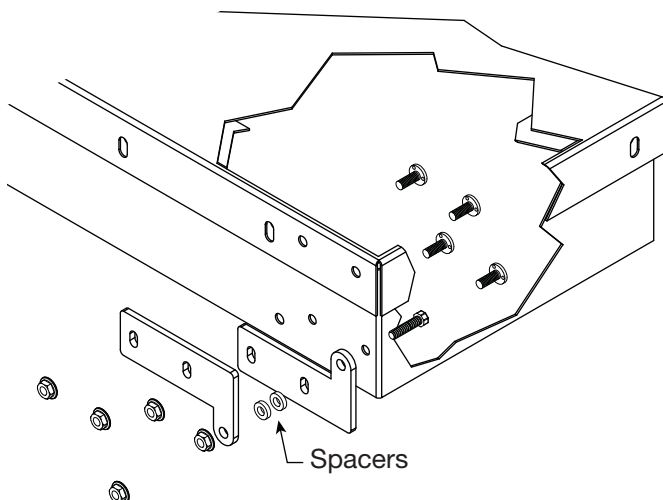

FIGURE 3



Installation

1. Check curb cap for factory holes that match the dimensions in FIGURES 1 and 2. If holes match, skip to Step 3. If not, drill 5/16 inch holes in curb cap using dimensions in FIGURES 1 and 2.
2. Attach “L” shaped hinge bracket to curb cap with two 1/4 inch -20 x 3/4 inch bolts per bracket. Leave finger tight until all pieces are installed. Refer to FIGURE 3.
3. Center curb cap on curb. Ensure there is equal space between curb and curb cap on all sides.
4. On one side, insert a 5/16 inch -18 x 1-1/2 inch bolt through the upper bracket. Place one of the remaining two “L” brackets on the bolt. Press lower bracket up against the curb to estimate the number of spacers. Use the spacers to take up the gap between the two “L” brackets. The number of spacers will vary from unit to unit. Install the 5/16 inch -18 nut until finger tight.
5. Pivot the lower hinge until parallel with the upper hinge and hold against the curb. Mark the two holes for drilling.
6. Allow the lower bracket to swing out of the way and drill a 5/16 inch hole in curb at the locations marked in Step 5.
7. Return lower bracket to parallel with the upper bracket and install two 1/4 inch -20 x 3/4 inch bolts. Leave finger tight.
8. Go to opposite side and repeat Steps 4 thru 7.
9. Center curb cap on curb and tighten all bolts.
10. Fasten side opposite of the hinges to the curb with appropriate fastener to keep unit from opening up in high wind events. See FIGURE 4.

FIGURE 4

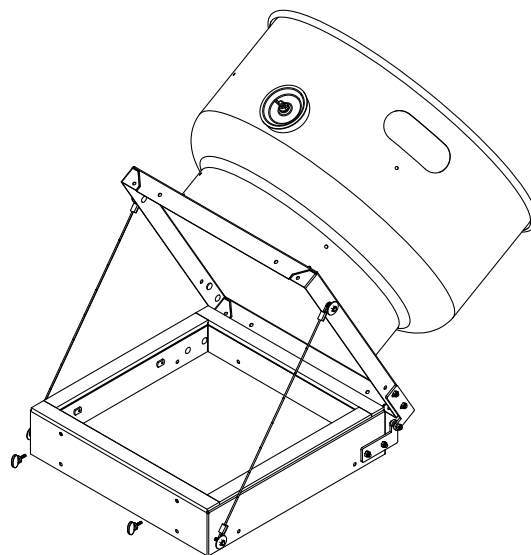
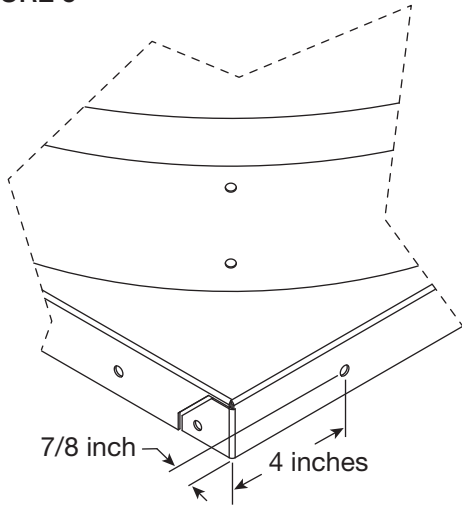

FIGURE 5



Installing the stop cable

1. Check one side of curb cap for factory-punched hole at or near dimensions indicated by FIGURE 5. If this hole exists, it can be used as the upper connection point for the stop cable. If not, a 5/16 inch hole needs to be drilled in the curb cap at the dimensions indicated in FIGURE 5.
2. Attach cable to curb cap as shown in FIGURE 6.
3. Drill a 5/16 inch hole in the curb at the dimensions indicated in FIGURE 7.
4. Attach the stop cable to curb and curb cap with 1/4 inch -20 x 3/4 inch bolts as shown in FIGURE 6. Must include 1-1/4 inch fender washer between bolt head and cable!

FIGURE 6

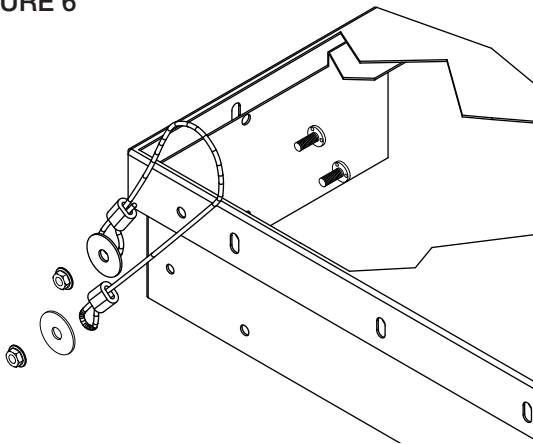
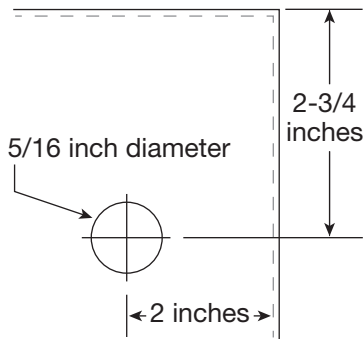

FIGURE 7



Our Commitment

As a result of our commitment to continuous improvement, Greenheck reserves the right to change specifications without notice.

Specific Greenheck product warranties are located on greenheck.com within the product area tabs and in the Library under Warranties.

