

GENERAL INFORMATION

SPECIFICATIONS

CROSS-REFERENCE

INSTALLATION DRAWINGS

## 4E. SELF-PRIMING UNIVERSAL/ELECTRIC

### PUMP SERIES:

3CCE/4CCE/5CCE

10CCE

15CCE

20CCE

25CCE

5CU-1

7CU-1

10ICU-1

15ICU-1

20ICU-1

25ICU-1

TS7

BH7

B30

B40

B60

This page intentionally left blank

### Self-Priming Universal/Electric Driven

*Previous Models		Current Models		
MODEL	P/N	MODEL	P/N	PAGE NO.
		3CCE	027458	1 - 3
		3CCE-1	027460	1 - 3
		4CCE	027464	1 - 3
		4CCE-1	027466	1 - 3
		5CCE	027470	1 - 3
		5CCE-1	027472	1 - 3
		10CCE	028506	4 - 6
		10CCE-1	028504	4 - 6
		15CCE	028508	7 - 9
		20CCE	028510	10 - 12
		25CCE	028512	13 - 15
		5CU-1	019130	16 - 18
		7CU-1	018902	19 - 21
		10 ICU-1	033762	22 - 24
		15 ICU-1	052596	25 - 27
		20 ICU-1	052624	28 - 30
		25 ICU-1	052626	31 - 33
2MSP-U	074059	-----	-----	
30MU	031272			
		90MU	072118	37 - 39
1C25D	1C25D-0006B-001	TS7	1C25D-0006B-001	40 - 43
1C0QD	1C0QD-0004S-001			
	1C0QD-0004S-002			
1C0RD	1C0RD-0004S-001			
1C0RD	1C0RD-0004S-002			
2C0SD	2C0SD-0004S-001			
2C0SD	2C0SD-0004S-002			
2C0TD	2C0TD-0005F-001			
2C0TD	2C0TD-0005F-002			
2C0UD	2C0UD-0006D-001	BH7	2C0UD-0006D-001	51 - 54, 59 - 60
2C0UD	2C0UD-0006D-002	SBH7	2C0UD-0006D-002	51 - 54, 59 - 60
3C0VD	3C0VD-0005F-001			
3C0VD	3C0VD-0005F-002			
3C0WD	3C0WD-0005J-001			
3C0WD	3C0WD-0005J-002			
3C0XD	3C0XD-0007X-001	B30	3C0XD-0007X-001	61 - 65

Previous Models are Discontinued. Consult Factory for current replacement if not shown.

# Cross-Reference Chart

Engineered Pump

# BARNES®

www.cranepumps.com

## Self-Priming Universal/Electric Driven

*Previous Models		Current Models		
MODEL	P/N	MODEL	P/N	PAGE NO.
4C0YD	4C0YD-0010X-001	B40-10X	4C0YD-0010X-001	66 - 72
4C0YD	4C0YD-0009H-001	B40-9H	4C0YD-0009H-001	66 - 72
4C0YD	4C0YD-0009D-001	B40-9D	4C0YD-0009D-001	66 - 72
4C0YD	4C0YD-0008F-001	B40-8F	4C0YD-0008F-001	66 - 72
6C0ZD	6C0ZD-0012X-001	B60-12X	6C0ZD-0012X-001	73 - 79
6C0ZD	6C0ZD-0012X-001	B60-11H	6C0ZD-0012X-001	73 - 79
6C0ZD	6C0ZD-0012X-001	B60-11X	6C0ZD-0012X-001	73 - 79
6C0ZD	6C0ZD-0012X-001	B60-10L	6C0ZD-0012X-001	73 - 79

Previous Models are Discontinued. Consult Factory for current replacement if not shown.

SECTION 4E  
PAGE D  
DATE 5/05

**CRANE**<sup>®</sup>

A Crane Co. Company

**PUMPS & SYSTEMS**

USA: (937) 778-8947 • Canada: (905) 457-6223 • International: (937) 615-3598

### Self-Priming Universal/Electric Driven

## Specifications:

SUCTION/DISCHARGE ..... 1½" x 1½" NPT, Female  
LIQUID TEMPERATURE ..... 160°F (71°C) Continuous  
INTERMEDIATE ..... Cast Iron ASTM A-48, Class 30  
VOLUTE ..... Cast Iron ASTM A-48, Class 30  
BODY ..... Cast Iron ASTM A-48, Class 30  
PEDESTAL ..... Cast Iron ASTM A-48, Class 30  
IMPELLER: *Design* ..... Open, Trash Type, Dynamically  
Balanced, ISO G6.3  
*Material* ..... Cast Iron ASTM A-48, Class 30  
SHAFT ..... Stainless Steel  
SQUARE RINGS ..... Buna-N  
HARDWARE ..... Series Stainless Steel  
PAINT ..... Air Dry Enamel.  
SEAL: *Design* ..... Mechanical  
*Lubrication* ..... Self-Lubricating  
*Material* ..... Rotating Faces - Carbon  
Stationary Faces - Ceramic  
Elastomer - Buna-N  
Hardware -300 Series Stainless  
CHECK VALVE:  
*Material* ..... Valve Flap-Neoprene  
Weight-Cast Iron ASTM A-48, Class 30  
MOTOR: *Design* ..... Open Drip Proof, NEMA L - Single Phase,  
NEMA B - Three Phase Torque Curve.  
C-Face, Footed, Squirrel Cage Induction  
*Insulation* ..... Class B  
SINGLE PHASE ..... Capacitor Start, Dual Voltage 115/230  
THREE PHASE ..... Tri-Voltage 200-230/460  
OPTIONAL EQUIPMENT ..... Seal Material, TEFC Motors

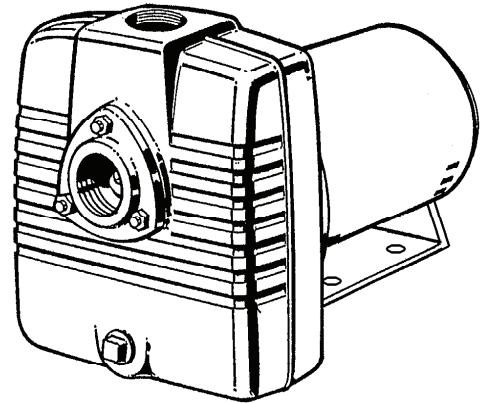

**Series: 3CCE**  
**1-1/2HP, 3450RPM**

**Series: 4CCE**  
**2HP, 3450RPM**

**Series: 5CCE**  
**3HP, 3450RPM**



® Canadian Standards Association  
File No. LR16567

## DESCRIPTION:

SELF-PRIMING CENTRIFUGAL PUMPS  
DESIGNED FOR MARINE, MUNICIPAL AND  
INDUSTRIAL APPLICATIONS

# Series 3CCE, 4CCE, 5CCE

Electric Drive

1½" NPT

# BARNES®

www.cranepumps.com

## Self-Priming Universal/Electric Driven

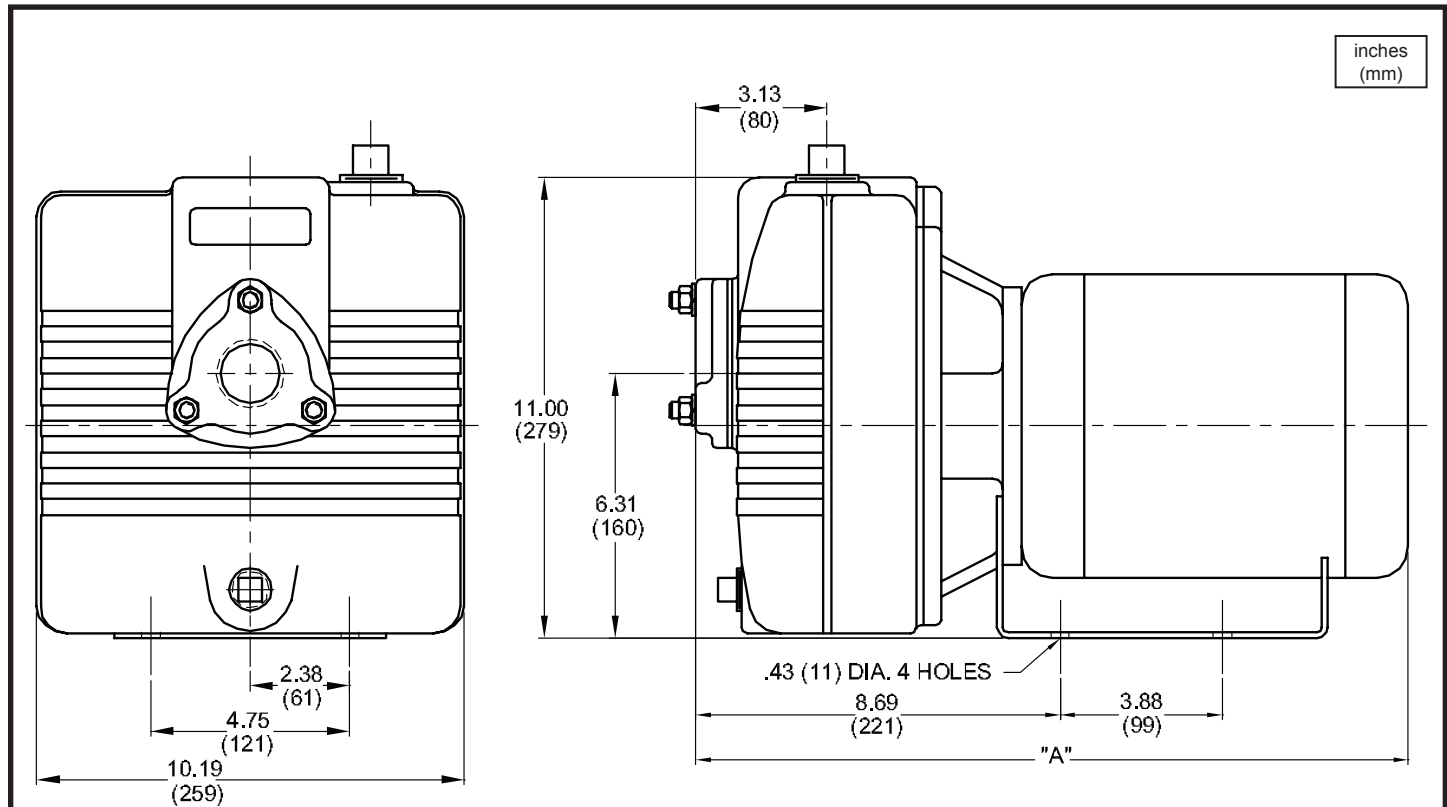

\* Overall Dimensions subject to Motor Manufacture.

MODEL NO	PART NO	MOTOR DESIGN	HP	VOLT	PH	Hz	RPM (Nom)	FULL LOAD AMPS	LOCKED ROTOR AMPS	WEIGHT NET LBS (kg)	* A DIM
3CCE	027458	ODP	1.5	200-230/460	3	60	3450	6.0/3.0	40/20	84 (38)	17.88 (454)
3CCE-1	027460	ODP	1.5	115/230	1	60	3450	4.5/2.3	120/60	84 (38)	18.44 (468)
4CCE	027464	ODP	2.0	200-230/460	3	60	3450	6.8/3.4	50/25	92 (42)	18.44 (468)
4CCE-1	027466	ODP	2.0	115/230	1	60	3450	5.9/3.0	144/72	92 (42)	18.44 (468)
5CCE	027470	ODP	3.0	200-230/460	3	60	3450	9.6/4.8	64/32	94 (43)	18.44 (468)
5CCE-1	027472	ODP	3.0	115/230	1	60	3450	8.3/4.2	204/102	94 (43)	19.69 (500)
3CCE	027458K	TEFC	1.5	200-230/460	3	60	3450	5-4.6/2.3	36/18	91 (41.3)	20.00 (508)
3CCE-1	027460K	TEFC	1.5	115/230	1	60	3450	16.6/8.3	84/42	107 (48.5)	21.00 (534)
4CCE	027464C	TEFC	2.0	200-230/460	3	60	3450	7-5.4/2.7	46/23	102 (46.3)	21.00 (534)
4CCE-1	027466M	TEFC	2.0	115/230	1	60	3450	23/11.5	156/78	120 (54.4)	21.92 (557)
5CCE	027470F	TEFC	3.0	200-230/460	3	60	3450	8.1-7.6/3.8	66/33	100 (45.4)	21.92 (557)
5CCE-1	027472J	TEFC	3.0	115/230	1	60	3450	29/14.5	172/86	134 (61)	25.36 (644)

### IMPORTANT !

- DO NOT USE FOR PUMPING FLUIDS WITH A FLASH POINT OF LESS THAN 100°F.
- MAKE CERTAIN THAT PUMP AND/OR MOTOR ASSEMBLY AND CONTROLS HAVE THE APPROPRIATE RATINGS FOR THE GIVEN APPLICATION AREA CLASSIFICATION. (ie DIVISION I, AGENCY LISTING ETC.)

SECTION 4E  
PAGE 2  
DATE 2/06

## CRANE®

A Crane Co. Company

## PUMPS & SYSTEMS

USA: (937) 778-8947 • Canada: (905) 457-6223 • International: (937) 615-3598

### Self-Priming Universal/Electric Driven

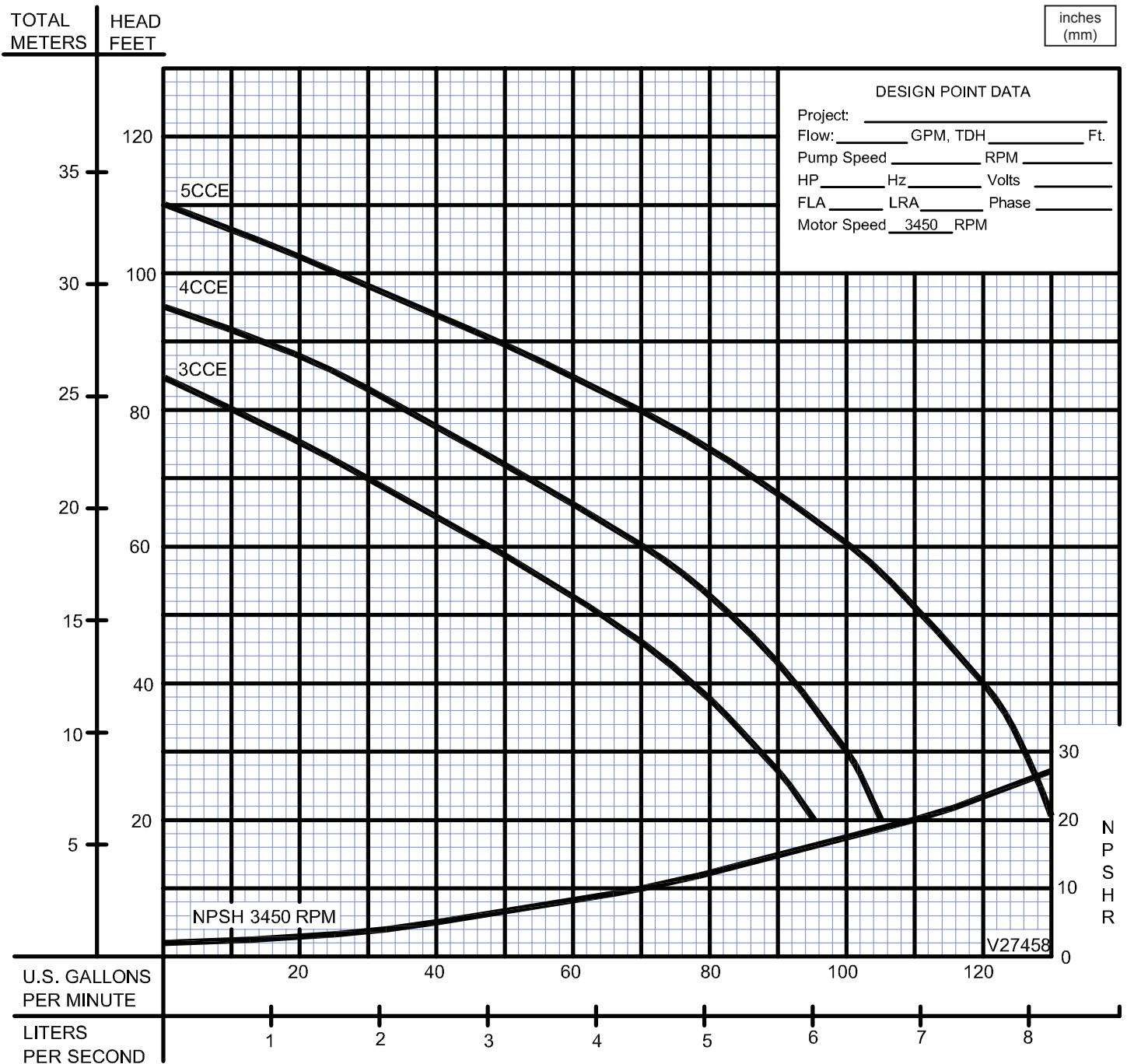

Testing is performed with water, specific gravity 1.0 @ 68° F @ (20°C), other fluids may vary performance

# Series 10CCE & 10CCE-1

Electric Drive  
2" NPT

# BARNES®

www.cranepumps.com

## Self-Priming Universal/Electric Driven

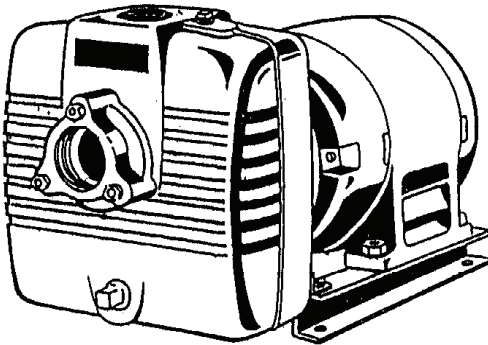

**Series: 10CCE & 10CCE-1  
5HP, 3450RPM**

### DESCRIPTION:

SELF-PRIMING CENTRIFUGAL PUMPS  
DESIGNED FOR MARINE, MUNICIPAL AND  
INDUSTRIAL APPLICATIONS

### Specifications:

SUCTION/DISCHARGE .....2" x 2" NPT, Female  
LIQUID TEMPERATURE .....160°F (71°C) Continuous  
INTERMEDIATE .....Cast Iron ASTM A-48, Class 30  
VOLUTE .....Cast Iron ASTM A-48, Class 30  
BODY .....Cast Iron ASTM A-48, Class 30  
PEDESTAL.....Cast Iron ASTM A-48, Class 30  
IMPELLER: *Design* .....Open, Trash Type, Dynamically  
Balanced, ISO G6.3  
*Material* .....Cast Iron ASTM A-48, Class 30  
SHAFT .....Stainless Steel  
SHAFT SLEEVE .....Bronze  
SQUARE RINGS .....Buna-N  
HARDWARE .....Series Stainless Steel  
PAINT .....Air Dry Enamel.  
SEAL: *Design* .....Mechanical  
*Lubrication* .....Self-Lubricating  
*Material* .....Rotating Faces - Carbon  
Stationary Faces - Ni-Resist  
Elastomer - Buna-N  
Hardware - 300 Series Stainless  
  
CHECK VALVE:  
*Material* .....Valve Flap-Neoprene  
Weight-Cast Iron ASTM A-48, Class 30  
MOTOR: *Design* .....Open Drip Proof, NEMA L - Single Phase,  
NEMA B - Three Phase Torque Curve.  
C-Face, Footed, Squirrel Cage Induction.  
Marine Duty Per USCG259 and  
AIEEE-45, 50°C Ambient  
*Insulation* .....Class B  
SINGLE PHASE .....Single Voltage 230  
THREE PHASE .....Tri-Voltage 200-230/460  
OPTIONAL EQUIPMENT.....Seal Material, TEFC Motors

SECTION 4E  
PAGE 4  
DATE 3/12

**CRANE**®

A Crane Co. Company

**PUMPS & SYSTEMS**

USA: (937) 778-8947 • Canada: (905) 457-6223 • International: (937) 615-3598



### Self-Priming Universal/Electric Driven

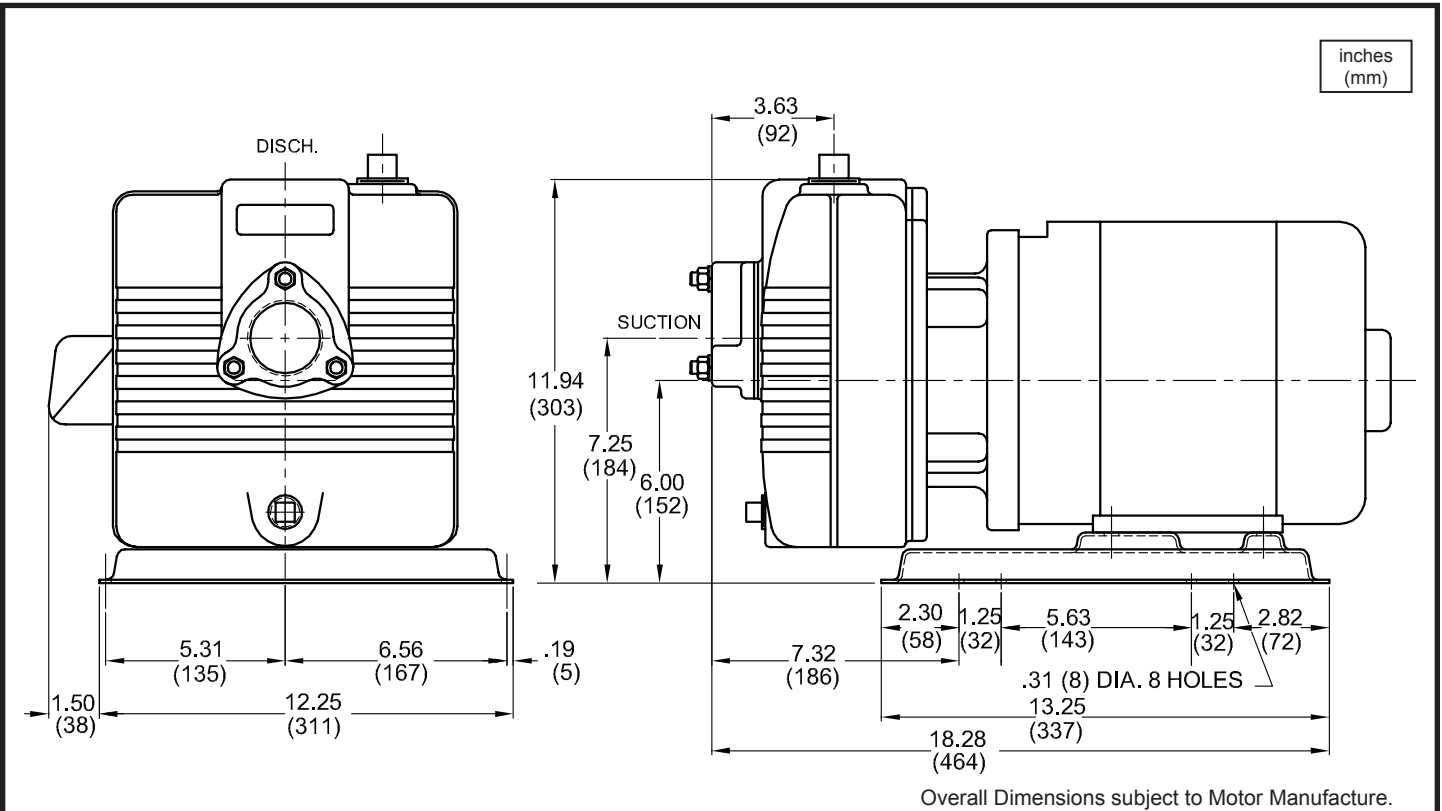

MODEL NO	PART NO	MOTOR DESIGN	HP	VOLT	PH	Hz	RPM (Nom)	FULL LOAD AMPS	LOCKED ROTOR AMPS	WEIGHT NET LBS (kg)
10CCE	028506	ODP	5.0	200-230/460	3	60	3450	15.2/7.6	92/46	164 (74)
10CCE-1	028504	ODP	5.0	230	1	60	3450	23	125	164 (74)
10CCE	028506F	TEFC	5.0	200-230/460	3	60	3450	6 @ 460	47 @ 460	193 (88)
10CCE-1	028504F	TEFC	5.0	230	1	60	3450	23	170	185 (84)

**IMPORTANT !**

- DO NOT USE FOR PUMPING FLUIDS WITH A FLASH POINT OF LESS THAN 100°F.
- MAKE CERTAIN THAT PUMP AND/OR MOTOR ASSEMBLY AND CONTROLS HAVE THE APPROPRIATE RATINGS FOR THE GIVEN APPLICATION AREA CLASSIFICATION. (ie DIVISION I, AGENCY LISTING ETC.)

# Series 10CCE & 10CCE-1

Performance Curve  
Electric Drive

# BARNES®

www.cranepumps.com

## Self-Priming Universal/Electric Driven

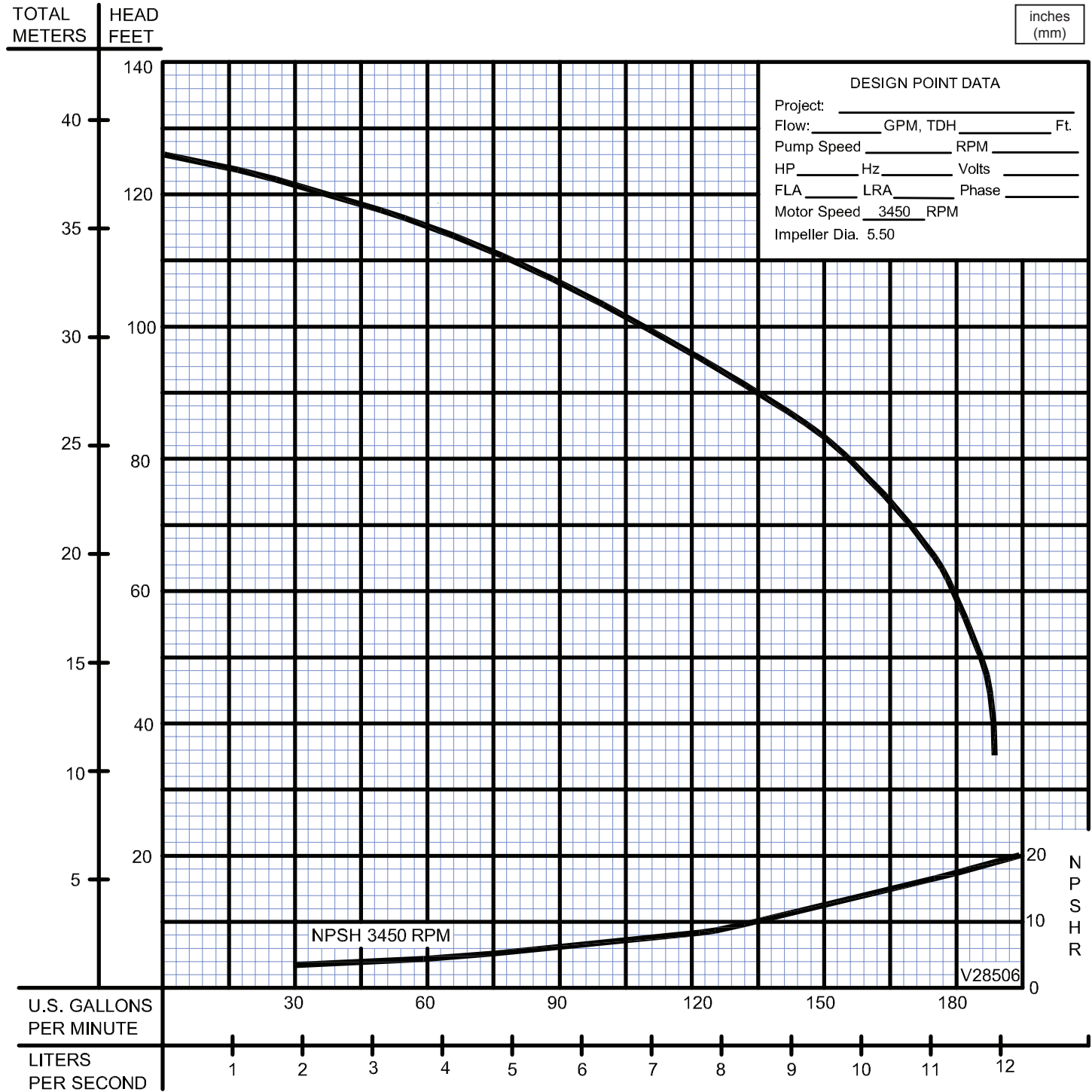

Testing is performed with water, specific gravity 1.0 @ 68° F @ (20°C), other fluids may vary performance

SECTION 4E  
PAGE 6  
DATE 5/05

**CRANE**  
A Crane Co. Company

PUMPS & SYSTEMS

USA: (937) 778-8947 • Canada: (905) 457-6223 • International: (937) 615-3598

### Self-Priming Universal/Electric Driven

## Specifications:

SUCTION/DISCHARGE .....3" x 3" NPT, Female  
LIQUID TEMPERATURE .....160°F (71°C) Continuous  
INTERMEDIATE .....Cast Iron ASTM A-48, Class 30  
VOLUTE .....Cast Iron ASTM A-48, Class 30  
BODY .....Cast Iron ASTM A-48, Class 30  
PEDESTAL .....Cast Iron ASTM A-48, Class 30  
IMPELLER: *Design* .....Open, Trash Type, Dynamically  
Balanced, ISO G6.3  
*Material* .....Cast Iron ASTM A-48, Class 30  
SHAFT .....Stainless Steel  
SHAFT SLEEVE .....Bronze  
SQUARE RINGS .....Buna-N  
HARDWARE .....Series Stainless Steel  
PAINT .....Air Dry Enamel.  
SEAL: *Design* .....Mechanical  
*Lubrication* .....Self-Lubricating  
*Material* .....Rotating Faces - Carbon  
Stationary Faces - Ni-Resist  
Elastomer - Buna-N  
Hardware -300 Series Stainless  
CHECK VALVE:  
*Material* .....Valve Flap-Neoprene  
Weight-Cast Iron ASTM A-48, Class 30  
MOTOR: *Design* .....Open Drip Proof, NEMA B - Three Phase,  
Torque Curve. C-Face, Footed, Squirrel  
Cage Induction. Marine Duty Per  
USCG259 and AIEEEE-45, 50°C Ambient  
*Insulation* .....Class B  
THREE PHASE .....Tri-Voltage 200-230/460  
OPTIONAL EQUIPMENT .....Seal Material, TEFC Motors

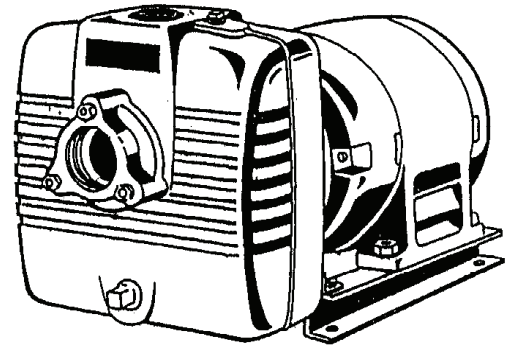

**Series: 15CCE**  
**7.5HP, 3450RPM**

## DESCRIPTION:

SELF-PRIMING CENTRIFUGAL PUMPS  
DESIGNED FOR MARINE, MUNICIPAL AND  
INDUSTRIAL APPLICATIONS

# Series 15CCE

Electric Drive  
3" NPT

# BARNES®

www.cranepumps.com

## Self-Priming Universal/Electric Driven

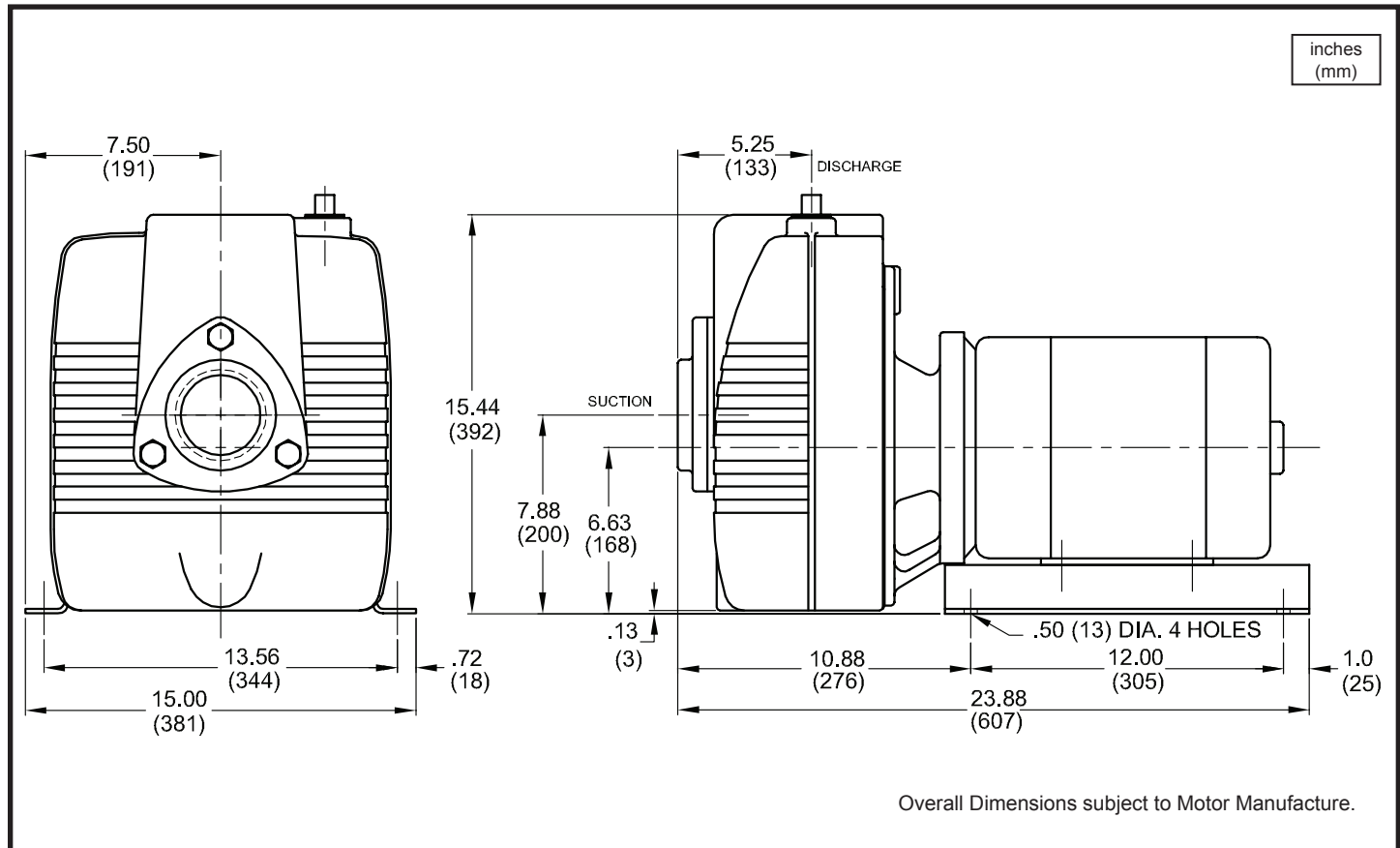

MODEL NO	PART NO	MOTOR DESIGN	HP	VOLT	PH	Hz	RPM (Nom)	FULL LOAD AMPS	LOCKED ROTOR AMPS	WEIGHT NET LBS (kg)
15CCE	028508	ODP	7.5	200-230/460	3	60	3450	22/11	127/63.5	248 (113)
15CCE	028508F	TEFC	7.5	200-230/460	3	60	3450	20-19.2/9.6		278 (126)

### IMPORTANT !

- DO NOT USE FOR PUMPING FLUIDS WITH A FLASH POINT OF LESS THAN 100°F.
- MAKE CERTAIN THAT PUMP AND/OR MOTOR ASSEMBLY AND CONTROLS HAVE THE APPROPRIATE RATINGS FOR THE GIVEN APPLICATION AREA CLASSIFICATION. (ie DIVISION I, AGENCY LISTING ETC.)

SECTION 4E  
PAGE 8  
DATE 2/06

## CRANE®

A Crane Co. Company

## PUMPS & SYSTEMS

USA: (937) 778-8947 • Canada: (905) 457-6223 • International: (937) 615-3598

### Self-Priming Universal/Electric Driven

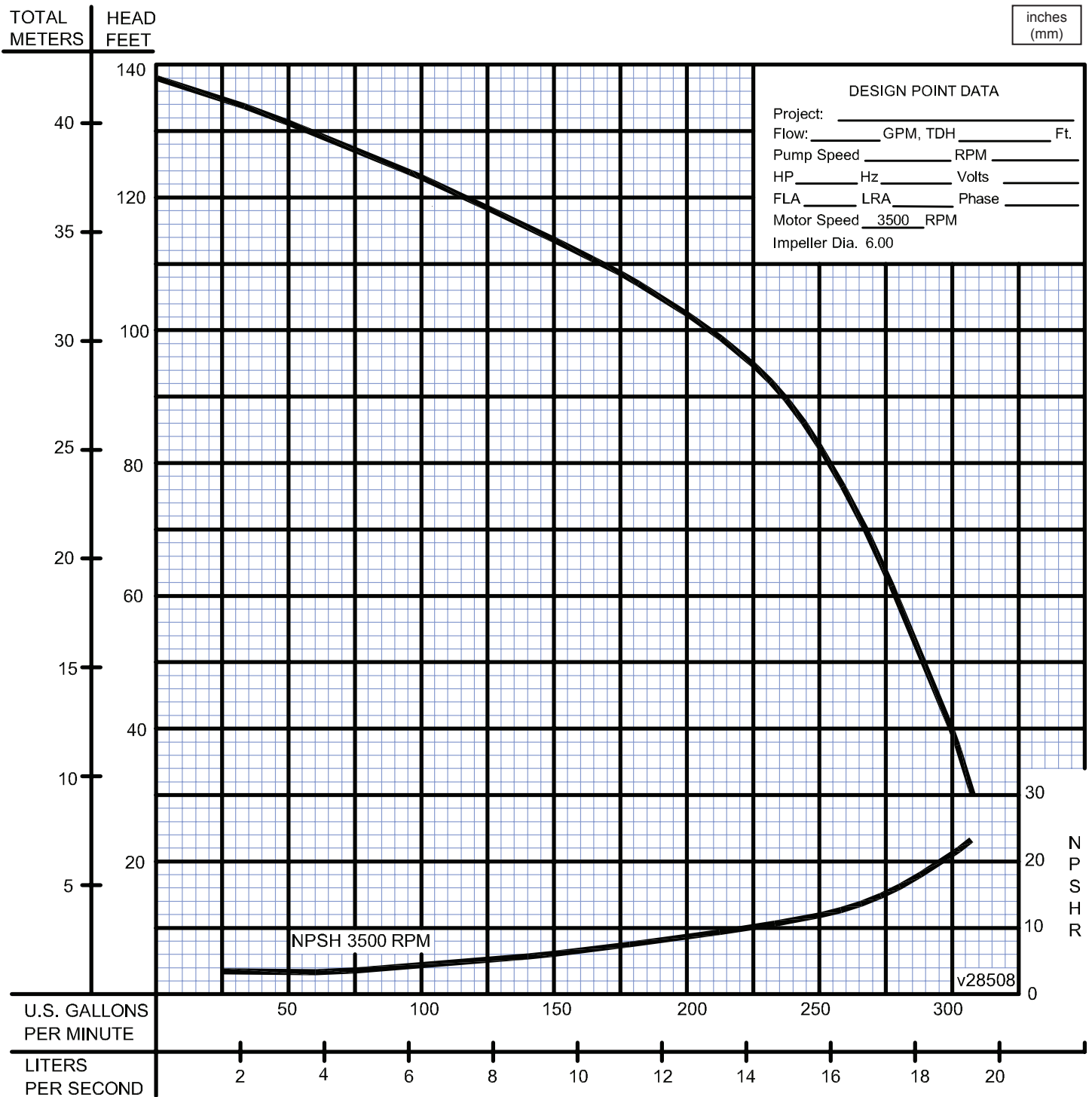

Testing is performed with water, specific gravity 1.0 @ 68° F @ (20°C), other fluids may vary performance

# Series 20CCE

Electric Drive  
3" NPT

# BARNES®

www.cranepumps.com

## Self-Priming Universal/Electric Driven

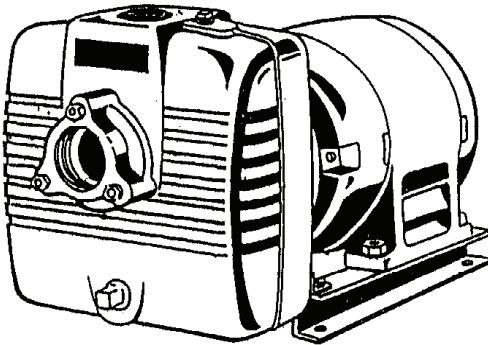

**Series: 20CCE**  
**10HP, 3450RPM**

### DESCRIPTION:

SELF-PRIMING CENTRIFUGAL PUMPS  
DESIGNED FOR MARINE, MUNICIPAL AND  
INDUSTRIAL APPLICATIONS

### Specifications:

SUCTION/DISCHARGE .....3" x 3" NPT, Female  
LIQUID TEMPERATURE .....160°F (71°C) Continuous  
INTERMEDIATE .....Cast Iron ASTM A-48, Class 30  
VOLUTE .....Cast Iron ASTM A-48, Class 30  
BODY .....Cast Iron ASTM A-48, Class 30  
PEDESTAL.....Cast Iron ASTM A-48, Class 30  
IMPELLER: *Design* .....Open, Trash Type, Dynamically  
Balanced, ISO G6.3  
*Material* .....Cast Iron ASTM A-48, Class 30  
SHAFT .....Stainless Steel  
SHAFT SLEEVE .....Bronze  
SQUARE RINGS .....Buna-N  
HARDWARE .....Series Stainless Steel  
PAINT .....Air Dry Enamel.  
SEAL: *Design* .....Mechanical  
*Lubrication* .....Self-Lubricating  
*Material* .....Rotating Faces - Carbon  
Stationary Faces - Ni-Resist  
Elastomer - Buna-N  
Hardware - 300 Series Stainless  
  
CHECK VALVE:  
*Material* .....Valve Flap-Neoprene  
Weight-Cast Iron ASTM A-48, Class 30  
MOTOR: *Design* .....Open Drip Proof, NEMA B - Three Phase,  
Torque Curve. C-Face, Footed, Squirrel  
Cage Induction. Marine Duty Per  
USCG259 and AIEEE-45, 50°C Ambient  
*Insulation* .....Class B  
THREE PHASE .....Tri-Voltage 200-230/460  
OPTIONAL EQUIPMENT.....Seal Material, TEFC Motors

SECTION 4E  
PAGE 10  
DATE 3/12

**CRANE**®

A Crane Co. Company

**PUMPS & SYSTEMS**

USA: (937) 778-8947 • Canada: (905) 457-6223 • International: (937) 615-3598

### Self-Priming Universal/Electric Driven

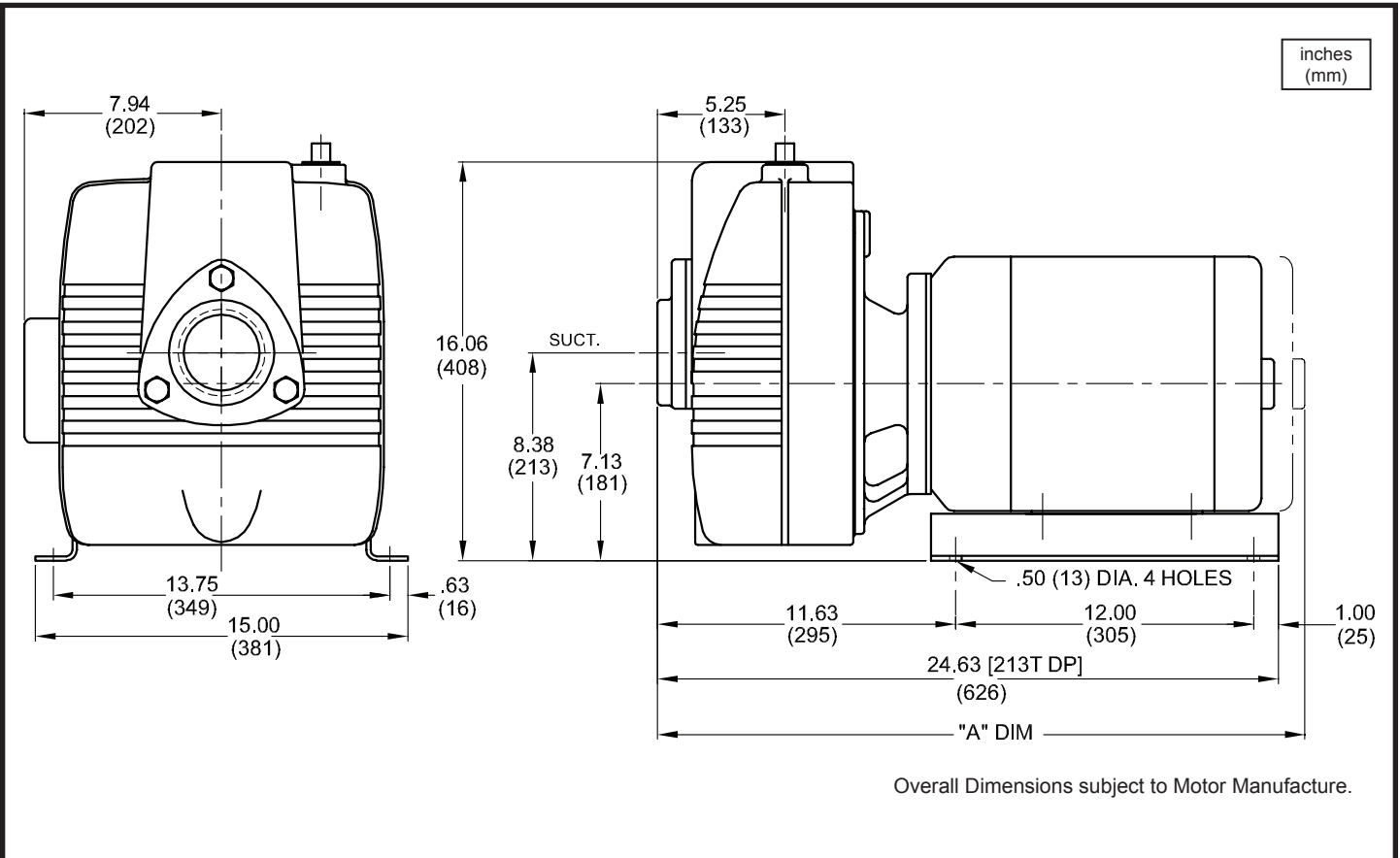

MODEL NO	PART NO	MOTOR DESIGN	HP	VOLT	PH	Hz	RPM (Nom)	FULL LOAD AMPS	LOCKED ROTOR AMPS	WEIGHT NET LBS (kg)
20CCE	028510	ODP	10	200-230/460	3	60	3450	28/14	162/81	294 (133)
20CCE	028510H	TEFC	10	200-230/460	3	60	3450	12 @ 460	115 @ 460	330 (150)

OPTIONAL MOTOR FRAMES	"A" DIM		
	215T - ODP	213T - TEFC	215T - TEFC
	25.69 (653)	26.88 (683)	27.63 (702)

**IMPORTANT !**

- DO NOT USE FOR PUMPING FLUIDS WITH A FLASH POINT OF LESS THAN 100°F.
- MAKE CERTAIN THAT PUMP AND/OR MOTOR ASSEMBLY AND CONTROLS HAVE THE APPROPRIATE RATINGS FOR THE GIVEN APPLICATION AREA CLASSIFICATION. (ie DIVISION I, AGENCY LISTING ETC.)

# Series 20CCE

Performance Curve  
Electric Drive

# BARNES®

www.cranepumps.com

## Self-Priming Universal/Electric Driven

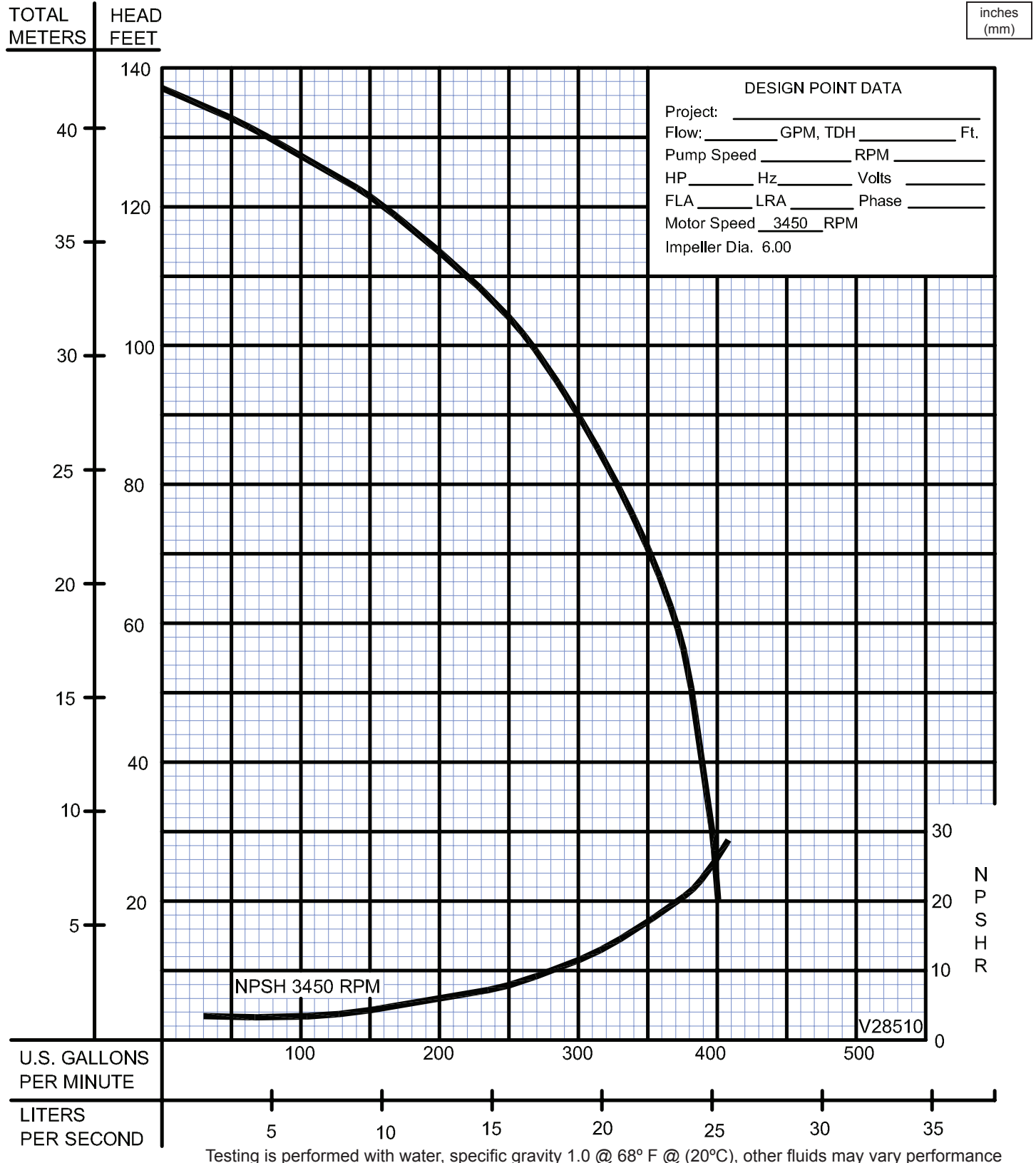

SECTION 4E  
PAGE 12  
DATE 5/05

**CRANE**  
A Crane Co. Company

**PUMPS & SYSTEMS**

USA: (937) 778-8947 • Canada: (905) 457-6223 • International: (937) 615-3598



### Self-Priming Universal/Electric Driven

## Specifications:

**SUCTION/DISCHARGE** .....3" x 3" NPT, Female  
**LIQUID TEMPERATURE** .....160°F (71°C) Continuous  
**INTERMEDIATE** .....Cast Iron ASTM A-48, Class 30  
**VOLUTE** .....Cast Iron ASTM A-48, Class 30  
**BODY** .....Cast Iron ASTM A-48, Class 30  
**PEDESTAL** .....Cast Iron ASTM A-48, Class 30  
**IMPELLER: Design** .....Open, Trash Type, Dynamically  
Balanced, ISO G6.3  
*Material* .....Cast Iron ASTM A-48, Class 30  
**SHAFT** .....Stainless Steel  
**SHAFT SLEEVE** .....Bronze  
**SQUARE RINGS** .....Buna-N  
**HARDWARE** .....Series Stainless Steel  
**PAINT** .....Air Dry Enamel.  
**SEAL:** *Design* .....Mechanical  
*Lubrication* .....Self-Lubricating  
*Material* .....Rotating Faces - Carbon  
Stationary Faces - Ni-Resist  
Elastomer - Buna-N  
Hardware -300 Series Stainless  
**CHECK VALVE:**  
*Material* .....Valve Flap-Neoprene  
Weight-Cast Iron ASTM A-48, Class 30  
**MOTOR: Design** .....Open Drip Proof, NEMA B - Three Phase,  
Torque Curve. C-Face, Footed, Squirrel  
Cage Induction. Marine Duty Per  
USCG259 and AIEEEE-45, 50°C Ambient  
*Insulation* .....Class B  
**THREE PHASE** .....Tri-Voltage 200-230/460  
**OPTIONAL EQUIPMENT** .....Seal Material, TEFC Motors

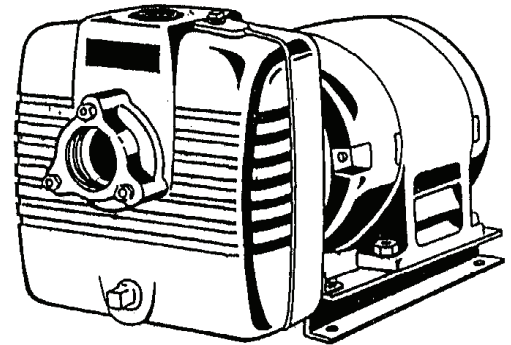

**Series: 25CCE**  
**15HP, 3450RPM**

## DESCRIPTION:

SELF-PRIMING CENTRIFUGAL PUMPS  
DESIGNED FOR MARINE, MUNICIPAL AND  
INDUSTRIAL APPLICATIONS

# Series 25CCE

Electric Drive  
3" NPT

# BARNES®

www.cranepumps.com

## Self-Priming Universal/Electric Driven

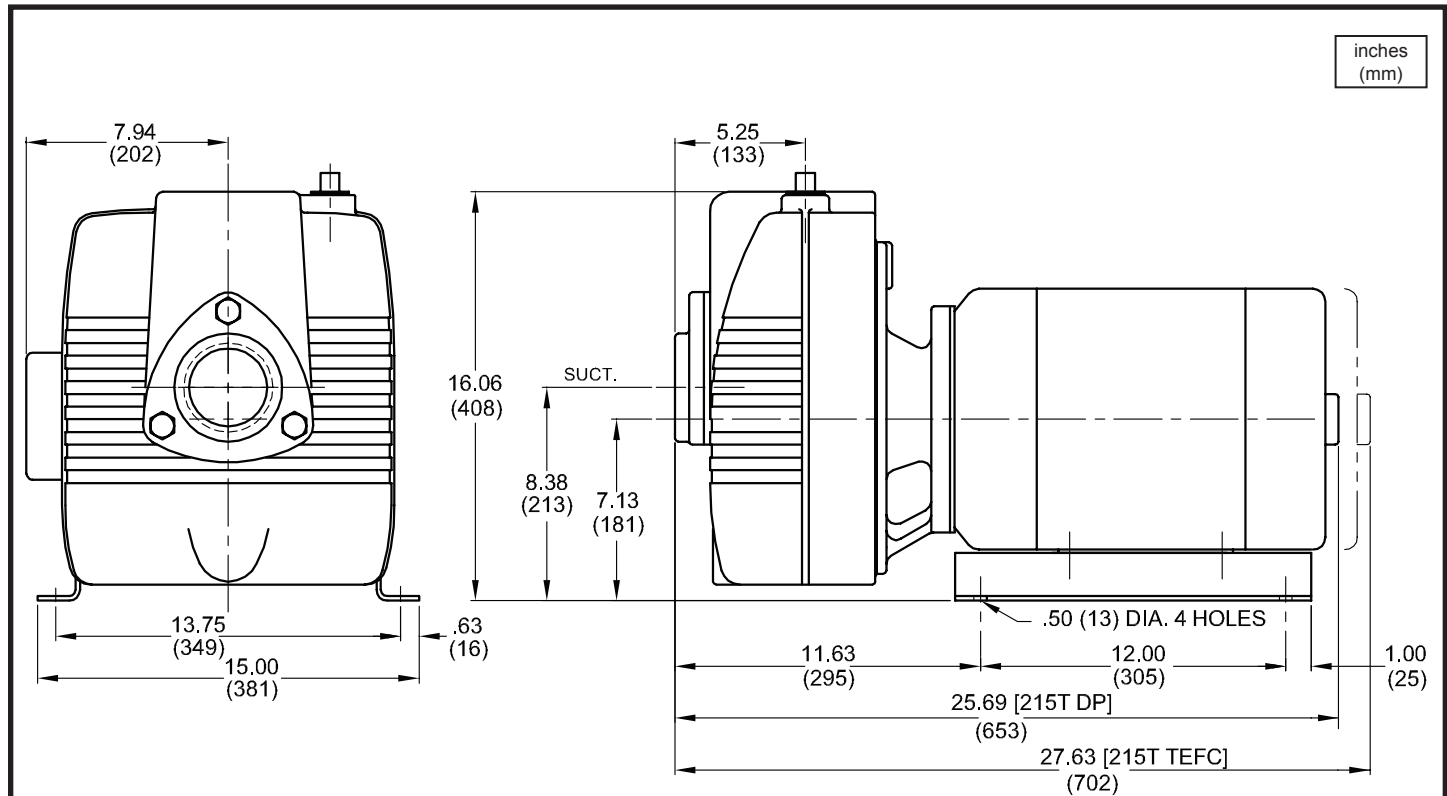

Overall Dimensions subject to Motor Manufacture.

MODEL NO	PART NO	MOTOR DESIGN	HP	VOLT	PH	Hz	RPM (Nom)	FULL LOAD AMPS	LOCKED ROTOR AMPS	WEIGHT NET LBS (kg)
25CCE	028512	ODP	15	200-230/460	3	60	3450	42/21	232/116	322 (146)
25CCE	028512D	TEFC	15	200-230/460	3	60	3450	18.5 @ 460	125 @ 460	384 (174)

### IMPORTANT !

- DO NOT USE FOR PUMPING FLUIDS WITH A FLASH POINT OF LESS THAN 100°F.
- MAKE CERTAIN THAT PUMP AND/OR MOTOR ASSEMBLY AND CONTROLS HAVE THE APPROPRIATE RATINGS FOR THE GIVEN APPLICATION AREA CLASSIFICATION. (ie DIVISION I, AGENCY LISTING ETC.)

SECTION 4E  
PAGE 14  
DATE 2/06

## CRANE®

A Crane Co. Company

## PUMPS & SYSTEMS

USA: (937) 778-8947 • Canada: (905) 457-6223 • International: (937) 615-3598

### Self-Priming Universal/Electric Driven

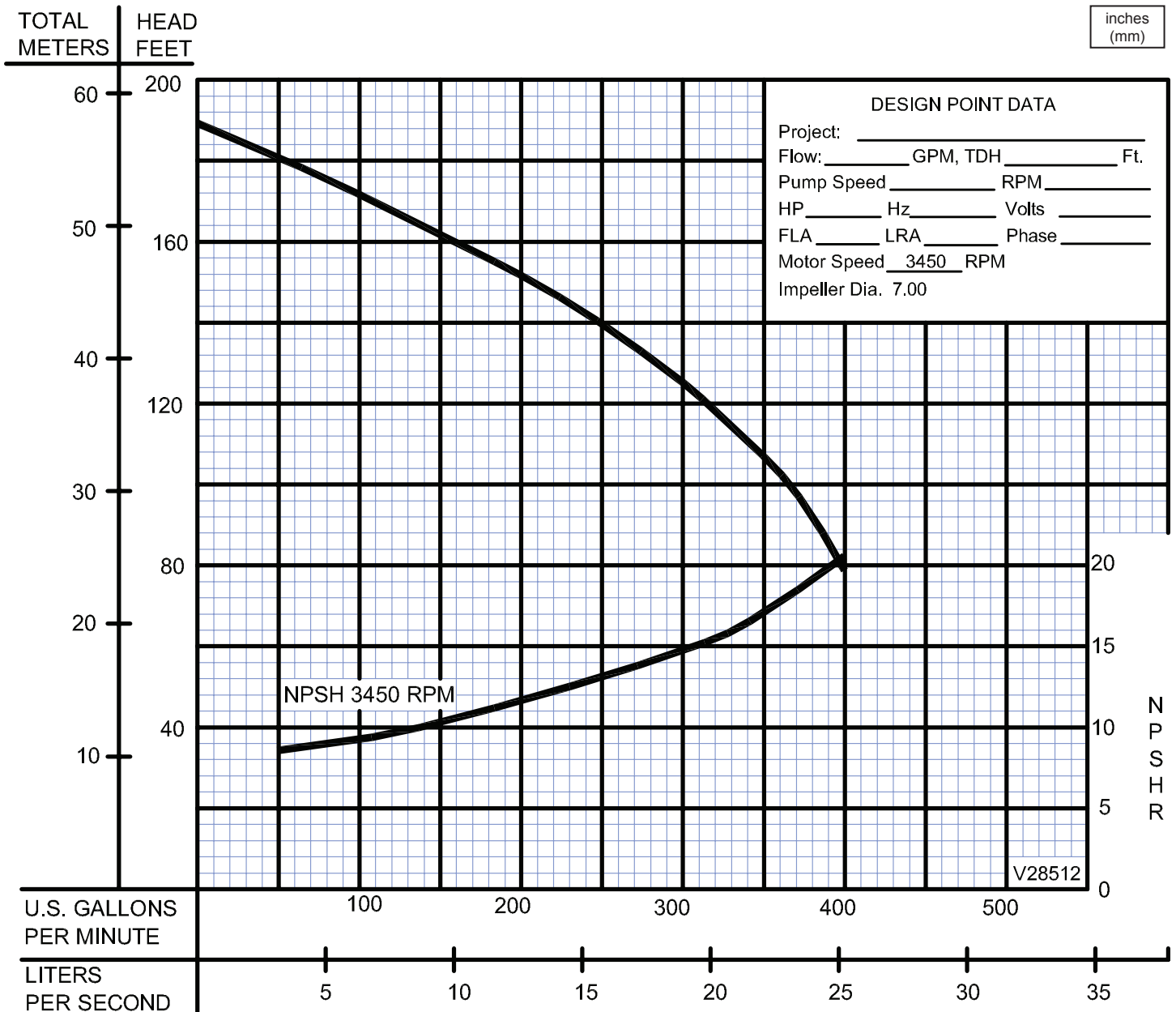

Testing is performed with water, specific gravity 1.0 @ 68° F @ (20°C), other fluids may vary performance

# Series 5CU-1

Pump End  
1½" NPT

# BARNES®

www.cranepumps.com

## Self-Priming Universal/Electric Driven

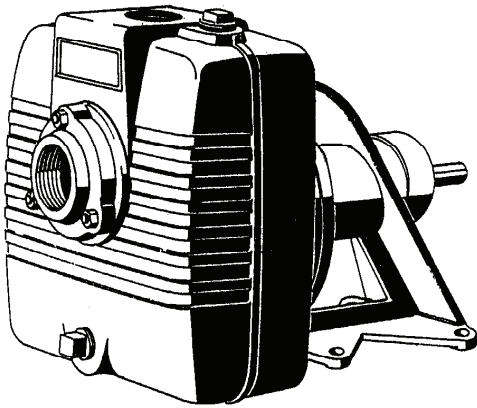

**Series: 5CU-1**

### DESCRIPTION:

SELF-PRIMING CENTRIFUGAL PUMPS  
DESIGNED FOR MARINE, MUNICIPAL AND  
INDUSTRIAL APPLICATIONS

### Specifications:

<b>SUCTION/DISCHARGE</b> .....	1½" x 1½" NPT, Female
<b>LIQUID TEMPERATURE</b> .....	160°F (71°C) Continuous
<b>INTERMEDIATE</b> .....	Cast Iron ASTM A-48, Class 30
<b>VOLUTE</b> .....	Cast Iron ASTM A-48, Class 30, Removable
<b>BODY</b> .....	Cast Iron ASTM A-48, Class 30
<b>PEDESTAL</b> .....	Cast Iron ASTM A-48, Class 30
<b>IMPELLER: Design</b> .....	Open, Trash Type, Dynamically Balanced, ISO G6.3
<b>Material</b> .....	Cast Iron ASTM A-48, Class 30
<b>SHAFT</b> .....	Stainless Steel
<b>SQUARE RINGS</b> .....	Buna-N
<b>HARDWARE</b> .....	Series Stainless Steel
<b>PAINT</b> .....	Air Dry Enamel.
<b>SEAL:</b>	
<i>Design</i> .....	Mechanical
<i>Lubrication</i> .....	Self-Lubricating
<i>Material</i> .....	Rotating Faces - Carbon Stationary Faces - Ceramic Elastomer - Buna-N Hardware - 300 Series Stainless
<b>BEARING - PUMP END:</b>	
<i>Design</i> .....	Single Row, Ball
<i>Lubrication</i> .....	Grease
<i>Load</i> .....	Radial
<b>BEARING - DRIVE END:</b>	
<i>Design</i> .....	Single Row, Ball
<i>Lubrication</i> .....	Grease
<i>Load</i> .....	Radial
<b>CHECK VALVE:</b>	
<i>Material</i> .....	Valve Flap-Neoprene Weight-Cast Iron ASTM A-48, Class 30
<b>OPTIONAL EQUIPMENT</b> .....	Seal Material, Flex Coupled Assy. with Base & OSHA Guard; Right Hand V-Belt Drive Assy., Left Hand V-Belt Drive Assy., and In-Line Vertical V-Belt Drive Assy. with Base, Motor Adjusting Base and OSHA Guard.

SECTION 4E  
PAGE 16  
DATE 10/07

**CRANE**<sup>®</sup>

A Crane Co. Company

**PUMPS & SYSTEMS**

USA: (937) 778-8947 • Canada: (905) 457-6223 • International: (937) 615-3598

### Self-Priming Universal/Electric Driven

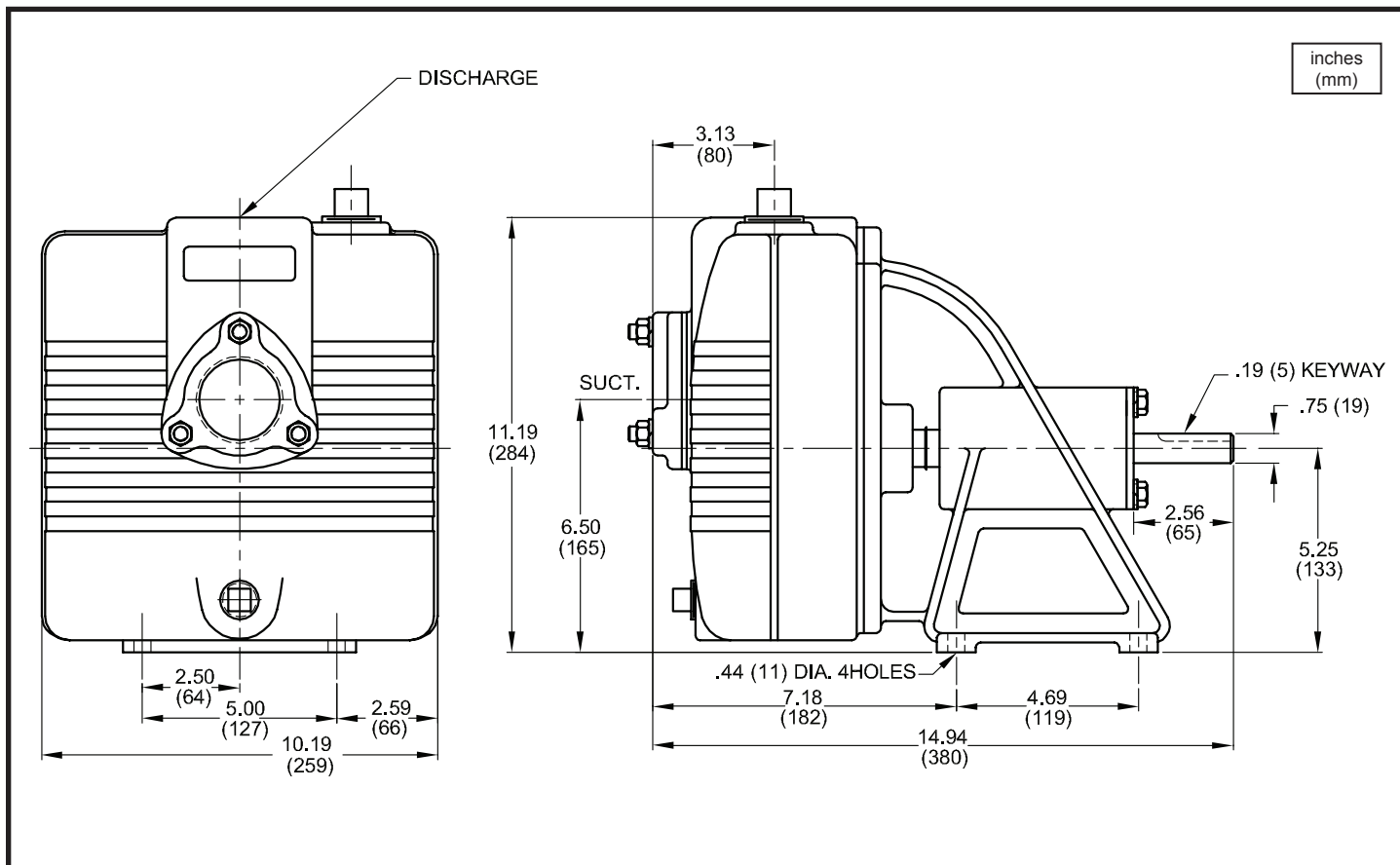

MODEL NO	PART NO	WEIGHT NET LBS (kg)
5CU-1	019130	78 (35.4)

**IMPORTANT !**

- DO NOT USE FOR PUMPING FLUIDS WITH A FLASH POINT OF LESS THAN 100°F.
- MAKE CERTAIN THAT PUMP AND/OR MOTOR ASSEMBLY AND CONTROLS HAVE THE APPROPRIATE RATINGS FOR THE GIVEN APPLICATION AREA CLASSIFICATION. (ie DIVISION I, AGENCY LISTING ETC.)

# Series 5CU-1

Performance Curve  
Electric Drive

# BARNES®

www.cranepumps.com

## Self-Priming Universal/Electric Driven

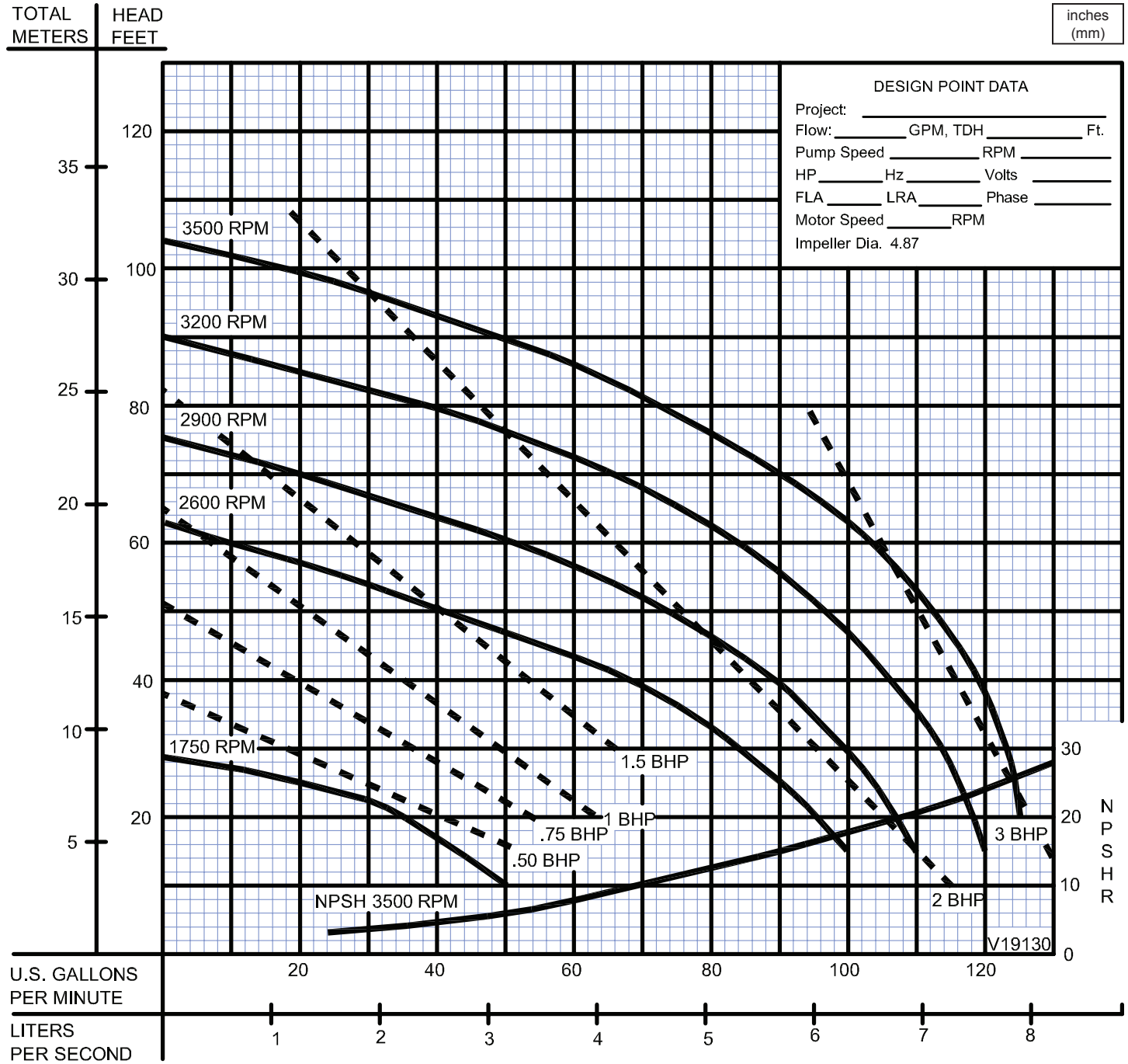

Testing is performed with water, specific gravity 1.0 @ 68° F @ (20°C), other fluids may vary performance

SECTION 4E  
PAGE 18  
DATE 5/05

**CRANE**  
A Crane Co. Company

PUMPS & SYSTEMS

USA: (937) 778-8947 • Canada: (905) 457-6223 • International: (937) 615-3598

### Self-Priming Universal/Electric Driven

## Specifications:

**SUCTION/DISCHARGE** .....2" x 2" NPT, Female  
**LIQUID TEMPERATURE** .....160°F (71°C) Continuous  
**INTERMEDIATE** .....Cast Iron ASTM A-48, Class 30  
**VOLUTE** .....Cast Iron ASTM A-48, Class 30,  
Remove  
**BODY** .....Cast Iron ASTM A-48, Class 30  
**PEDESTAL** .....Cast Iron ASTM A-48, Class 30  
**IMPELLER: Design** .....Open, Trash Type, Dynamically  
Balanced, ISO G6.3  
*Material* .....Cast Iron ASTM A-48, Class 30  
**SHAFT** .....Stainless Steel  
**SQUARE RINGS** .....Buna-N  
**HARDWARE** .....Series Stainless Steel  
**PAINT** .....Air Dry Enamel.  
**SEAL:** *Design* .....Mechanical  
*Lubrication* .....Self-Lubricating  
*Material* .....Rotating Faces - Carbon  
Stationary Faces - Ceramic  
Elastomer - Buna-N  
Hardware -300 Series Stainless  
**BEARING - PUMP END:**  
*Design*.....Single Row, Ball  
*Lubrication* .....Grease  
*Load*.....Radial  
**BEARING - DRIVE END:**  
*Design*.....Single Row, Ball  
*Lubrication* .....Grease  
*Load*.....Radial  
**CHECK VALVE:**  
*Material* .....Valve Flap-Neoprene  
Weight-Cast Iron ASTM A-48, Class 30  
**OPTIONAL EQUIPMENT**.....Seal Material, Flex Coupled Assy. with  
Base & OSHA Guard; Right Hand V-Belt Drive Assy., Left Hand V-Belt Drive  
Assy., and In-Line Vertical V-Belt Drive Assy. with Base, Motor Adjusting  
Base and OSHA Guard.

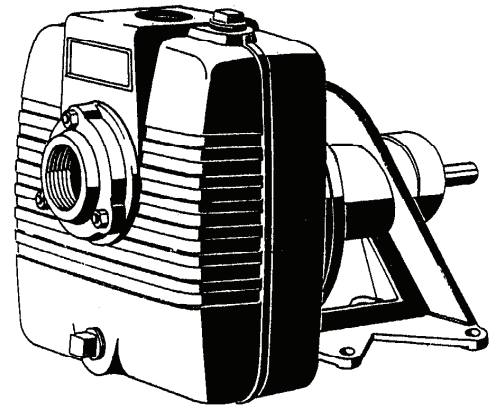

**Series: 7CU-1**

## DESCRIPTION:

SELF-PRIMING CENTRIFUGAL PUMPS  
DESIGNED FOR MARINE, MUNICIPAL AND  
INDUSTRIAL APPLICATIONS

# Series 7CU-1

Pump End  
2" NPT

# BARNES®

www.cranepumps.com

## Self-Priming Universal/Electric Driven

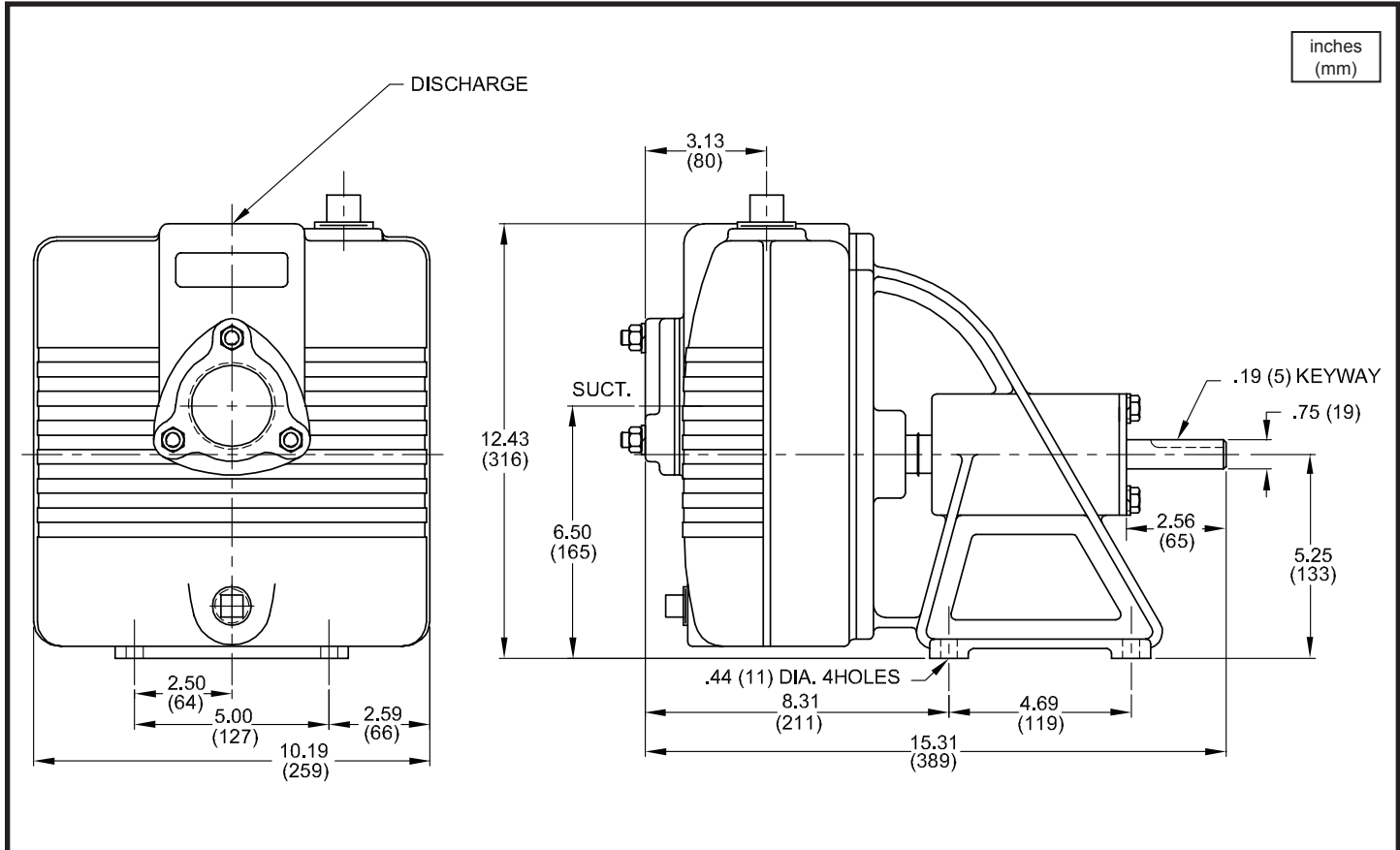

MODEL NO	PART NO	WEIGHT NET LBS (kg)	
7CU-1	018902	82 (37)	

### IMPORTANT !

- DO NOT USE FOR PUMPING FLUIDS WITH A FLASH POINT OF LESS THAN 100°F.
- MAKE CERTAIN THAT PUMP AND/OR MOTOR ASSEMBLY AND CONTROLS HAVE THE APPROPRIATE RATINGS FOR THE GIVEN APPLICATION AREA CLASSIFICATION. (ie DIVISION I, AGENCY LISTING ETC.)

SECTION 4E  
PAGE 20  
DATE 5/05

## CRANE®

A Crane Co. Company

## PUMPS & SYSTEMS

USA: (937) 778-8947 • Canada: (905) 457-6223 • International: (937) 615-3598



### Self-Priming Universal/Electric Driven

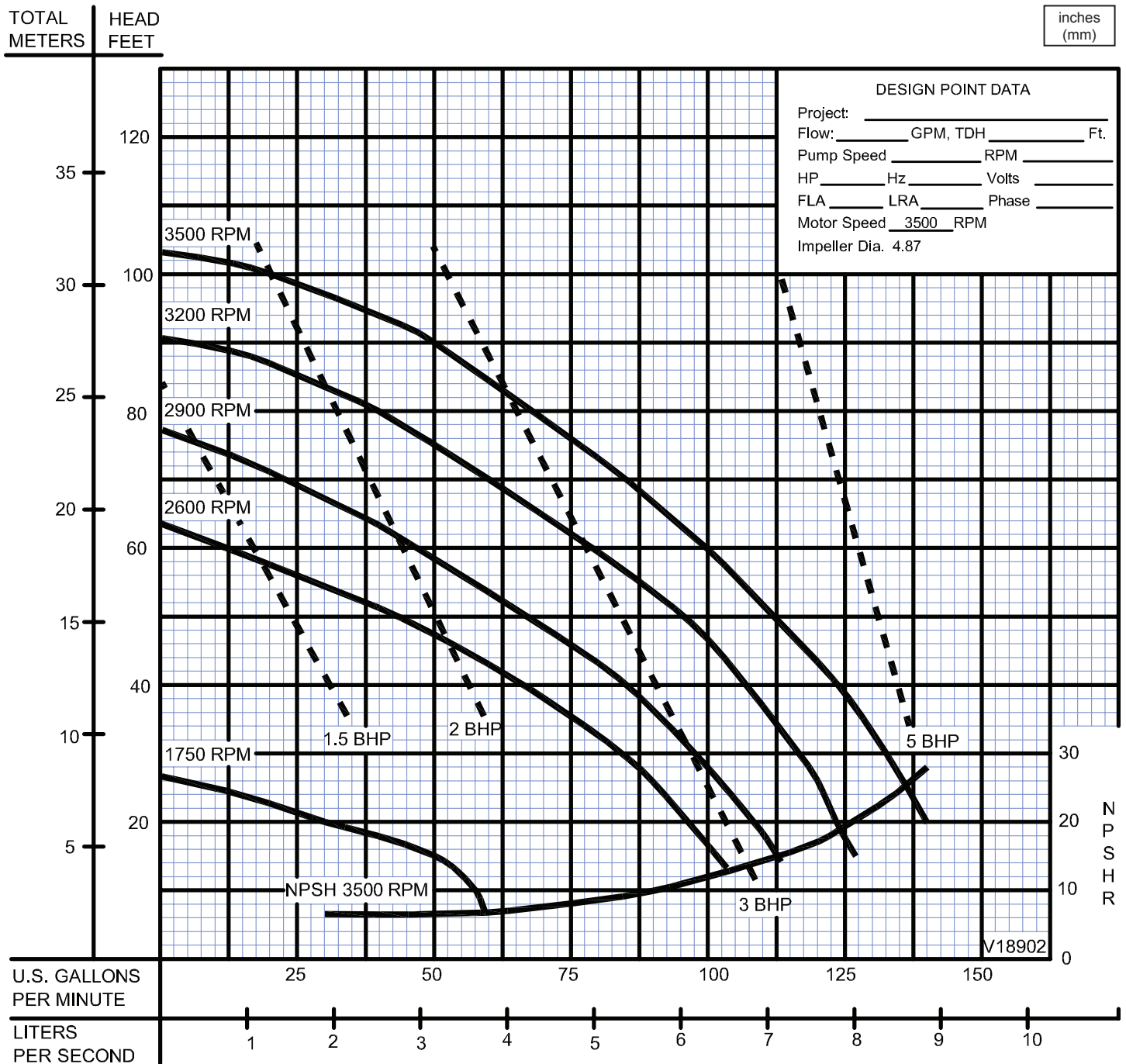

Testing is performed with water, specific gravity 1.0 @ 68° F @ (20°C), other fluids may vary performance

# Series 10ICU-1

Pump End  
2" NPT

# BARNES®

www.cranepumps.com

## Self-Priming Universal/Electric Driven

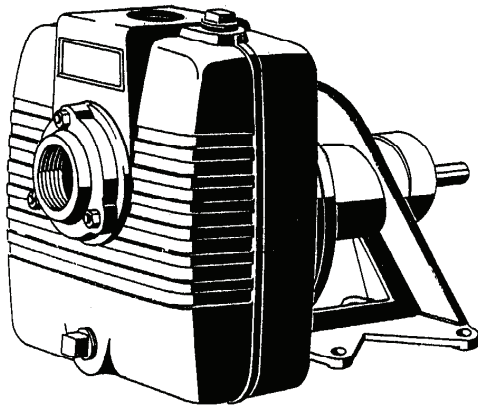

**Series: 10ICU-1**

## Specifications:

<b>SUCTION/DISCHARGE</b>	.....2" x 2" NPT, Female
<b>LIQUID TEMPERATURE</b>	.....160°F (71°C) Continuous
<b>INTERMEDIATE</b>	.....Cast Iron ASTM A-48, Class 30
<b>VOLUTE</b>	.....Cast Iron ASTM A-48, Class 30, Removable
<b>BODY</b>	.....Cast Iron ASTM A-48, Class 30
<b>PEDESTAL</b>	.....Cast Iron ASTM A-48, Class 30
<b>IMPELLER: Design</b>	.....Open, Trash Type, Dynamically Balanced, ISO G6.3
<b>Material</b>	.....Cast Iron ASTM A-48, Class 30
<b>SHAFT</b>	.....Stainless Steel
<b>SHAFT SLEEVE</b>	.....Stainless Steel
<b>SQUARE RINGS</b>	.....Buna-N
<b>HARDWARE</b>	.....Series Stainless Steel
<b>PAINT</b>	.....Air Dry Enamel.
<b>SEAL: Design</b>	.....Single Mechanical with Lip Seal
<b>Lubrication</b>	.....Grease
<b>Material</b>	.....Rotating Faces - Carbon Stationary Faces - Ceramic Elastomer - Buna-N Hardware - 300 Series Stainless
<b>BEARING - PUMP END:</b>	
<b>Design</b>	.....Single Row, Ball
<b>Lubrication</b>	.....Grease
<b>Load</b>	.....Radial
<b>BEARING - DRIVE END:</b>	
<b>Design</b>	.....Single Row, Ball
<b>Lubrication</b>	.....Grease
<b>Load</b>	.....Radial
<b>CHECK VALVE:</b>	
<b>Material</b>	.....Valve Flap-Neoprene Weight-Cast Iron ASTM A-48, Class 30
<b>OPTIONAL EQUIPMENT</b>	.....Seal Material, Flex Coupled Assy. with Base & OSHA Guard; Right Hand V-Belt Drive Assy., Left Hand V-Belt Drive Assy., and In-Line Vertical V-Belt Drive Assy. with Base, Motor Adjusting Base and OSHA Guard.

## DESCRIPTION:

SELF-PRIMING CENTRIFUGAL PUMPS  
DESIGNED FOR MARINE, MUNICIPAL AND  
INDUSTRIAL APPLICATIONS

SECTION 4E  
PAGE 22  
DATE 10/07

**CRANE**®

A Crane Co. Company

**PUMPS & SYSTEMS**

USA: (937) 778-8947 • Canada: (905) 457-6223 • International: (937) 615-3598

### Self-Priming Universal/Electric Driven

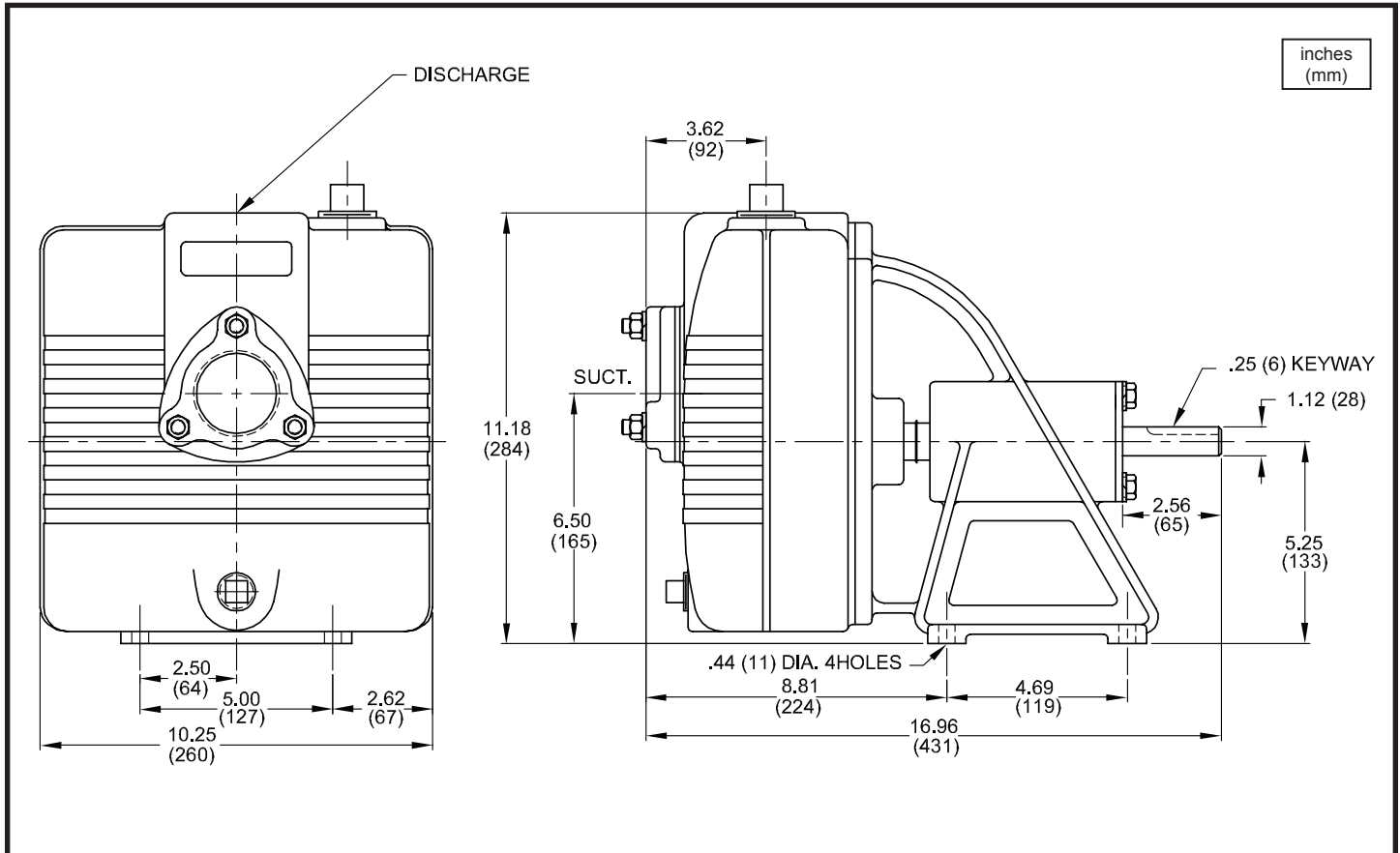

MODEL NO	PART NO	WEIGHT NET LBS (kg)
10ICU-1	033762	88 (40)

**IMPORTANT !**

- DO NOT USE FOR PUMPING FLUIDS WITH A FLASH POINT OF LESS THAN 100°F.
- MAKE CERTAIN THAT PUMP AND/OR MOTOR ASSEMBLY AND CONTROLS HAVE THE APPROPRIATE RATINGS FOR THE GIVEN APPLICATION AREA CLASSIFICATION. (ie DIVISION I, AGENCY LISTING ETC.)

# Series 10ICU-1

Performance Curve  
Pump End

# BARNES®

www.cranepumps.com

## Self-Priming Universal/Electric Driven

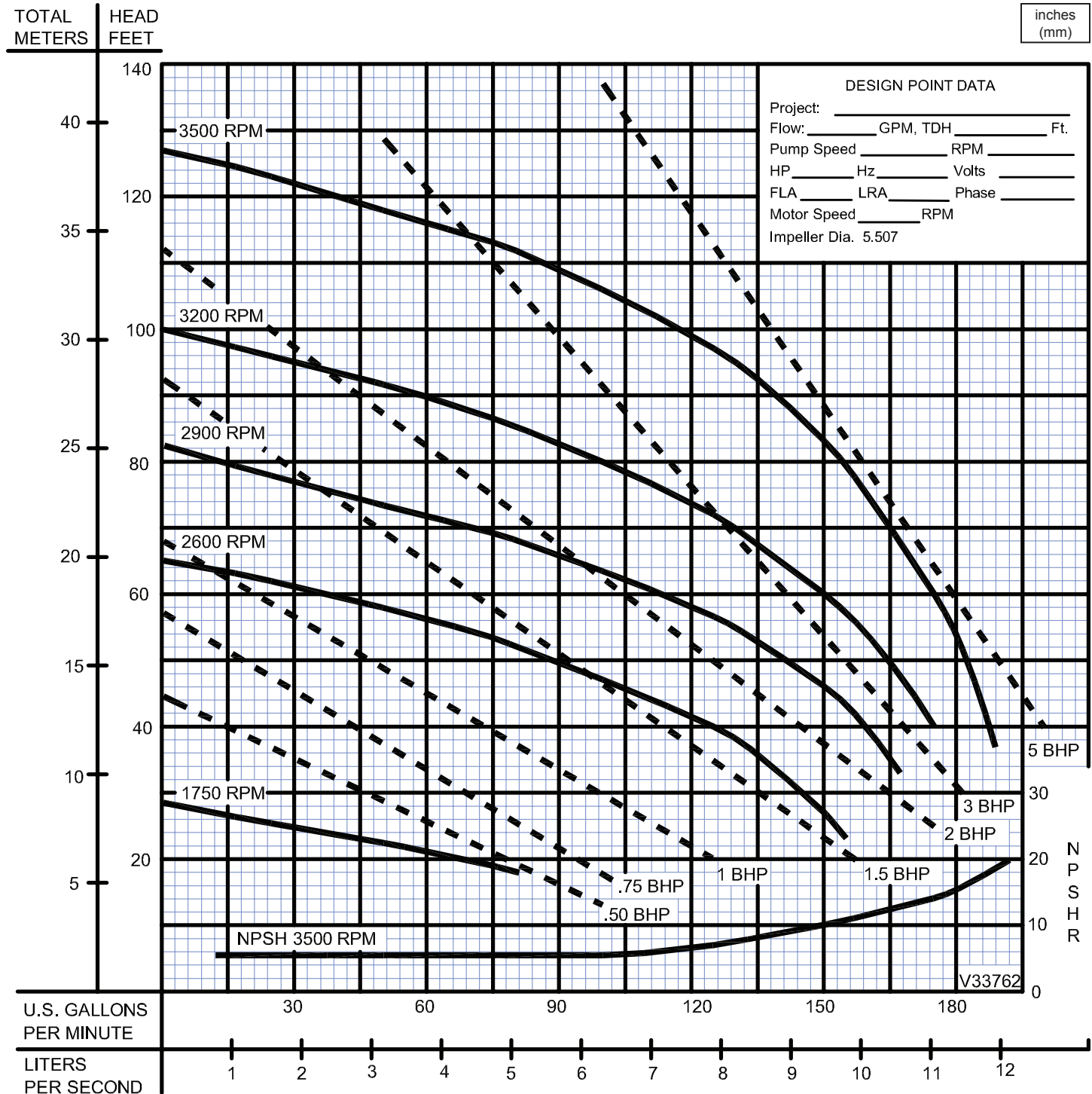

SECTION 4E  
PAGE 24  
DATE 5/05

**CRANE**  
A Crane Co. Company

PUMPS & SYSTEMS

USA: (937) 778-8947 • Canada: (905) 457-6223 • International: (937) 615-3598

### Self-Priming Universal/Electric Driven

## Specifications:

**SUCTION/DISCHARGE** .....3" x 3" NPT, Female  
**LIQUID TEMPERATURE** .....160°F (71°C) Continuous  
**INTERMEDIATE** .....Cast Iron ASTM A-48, Class 30  
**VOLUTE** .....Cast Iron ASTM A-48, Class 30,  
Removable  
**BODY** .....Cast Iron ASTM A-48, Class 30  
**PEDESTAL** .....Cast Iron ASTM A-48, Class 30  
**IMPELLER: Design** .....Open, Trash Type, Dynamically  
Balanced, ISO G6.3  
*Material* .....Cast Iron ASTM A-48, Class 30  
**SHAFT** .....Stainless Steel  
**SQUARE RINGS** .....Buna-N  
**HARDWARE** .....Series Stainless Steel  
**PAINT** .....Air Dry Enamel.  
**SEAL: Design** .....Single Mechanical with Lip Seal  
*Lubrication* .....Oil  
*Material* .....Rotating Faces - Carbon  
Stationary Faces - Ceramic  
Elastomer - Buna-N  
Hardware -300 Series Stainless

#### BEARING - PUMP END:

*Design*.....Single Row, Ball  
*Lubrication* .....Grease  
*Load*.....Radial

#### BEARING - DRIVE END:

*Design*.....Single Row, Ball  
*Lubrication* .....Grease  
*Load*.....Radial

#### CHECK VALVE:

*Material* .....Valve Flap-Neoprene  
Weight-Cast Iron ASTM A-48, Class 30

**OPTIONAL EQUIPMENT**.....Seal Material, Flex Coupled Assy. with  
Base & OSHA Guard; Right Hand V-Belt Drive Assy., Left Hand V-Belt Drive  
Assy., and In-Line Vertical V-Belt Drive Assy. with Base, Motor Adjusting  
Base and OSHA Guard.

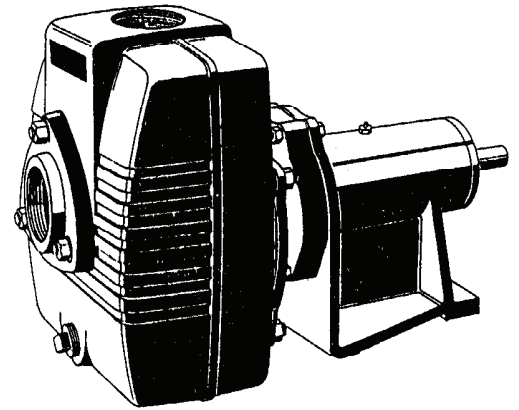

**Series: 15ICU-1**

## DESCRIPTION:

SELF-PRIMING CENTRIFUGAL PUMPS  
DESIGNED FOR MARINE, MUNICIPAL AND  
INDUSTRIAL APPLICATIONS

# Series 15ICU-1

Pump End  
3" NPT

# BARNES®

www.cranepumps.com

## Self-Priming Universal/Electric Driven

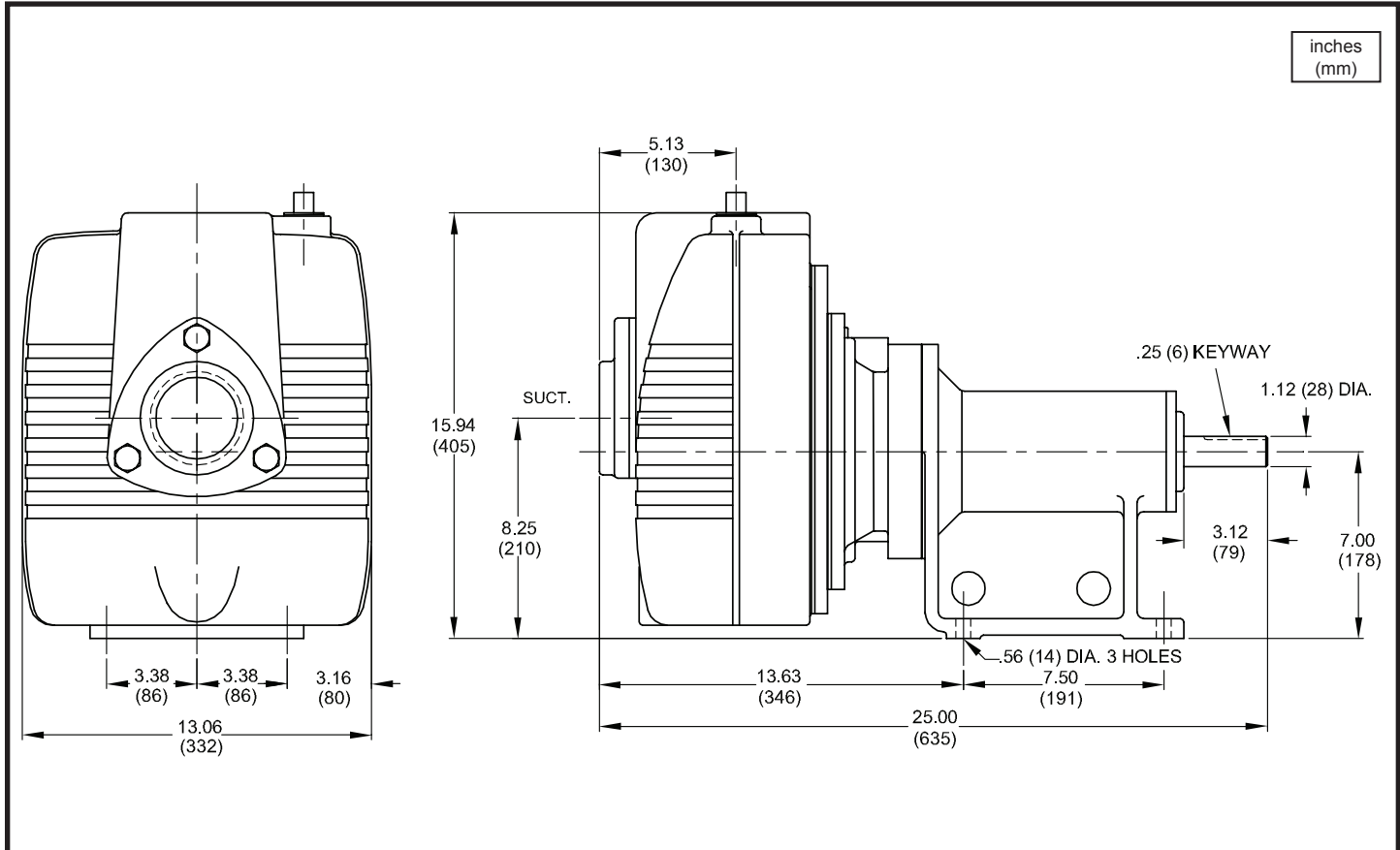

inches  
(mm)

MODEL NO	PART NO	WEIGHT NET LBS (kg)	
15ICU-1	052596	224 (102)	

### IMPORTANT !

- DO NOT USE FOR PUMPING FLUIDS WITH A FLASH POINT OF LESS THAN 100°F.
- MAKE CERTAIN THAT PUMP AND/OR MOTOR ASSEMBLY AND CONTROLS HAVE THE APPROPRIATE RATINGS FOR THE GIVEN APPLICATION AREA CLASSIFICATION. (ie DIVISION I, AGENCY LISTING ETC.)

SECTION 4E  
PAGE 26  
DATE 5/05

## CRANE®

A Crane Co. Company

## PUMPS & SYSTEMS

USA: (937) 778-8947 • Canada: (905) 457-6223 • International: (937) 615-3598

### Self-Priming Universal/Electric Driven

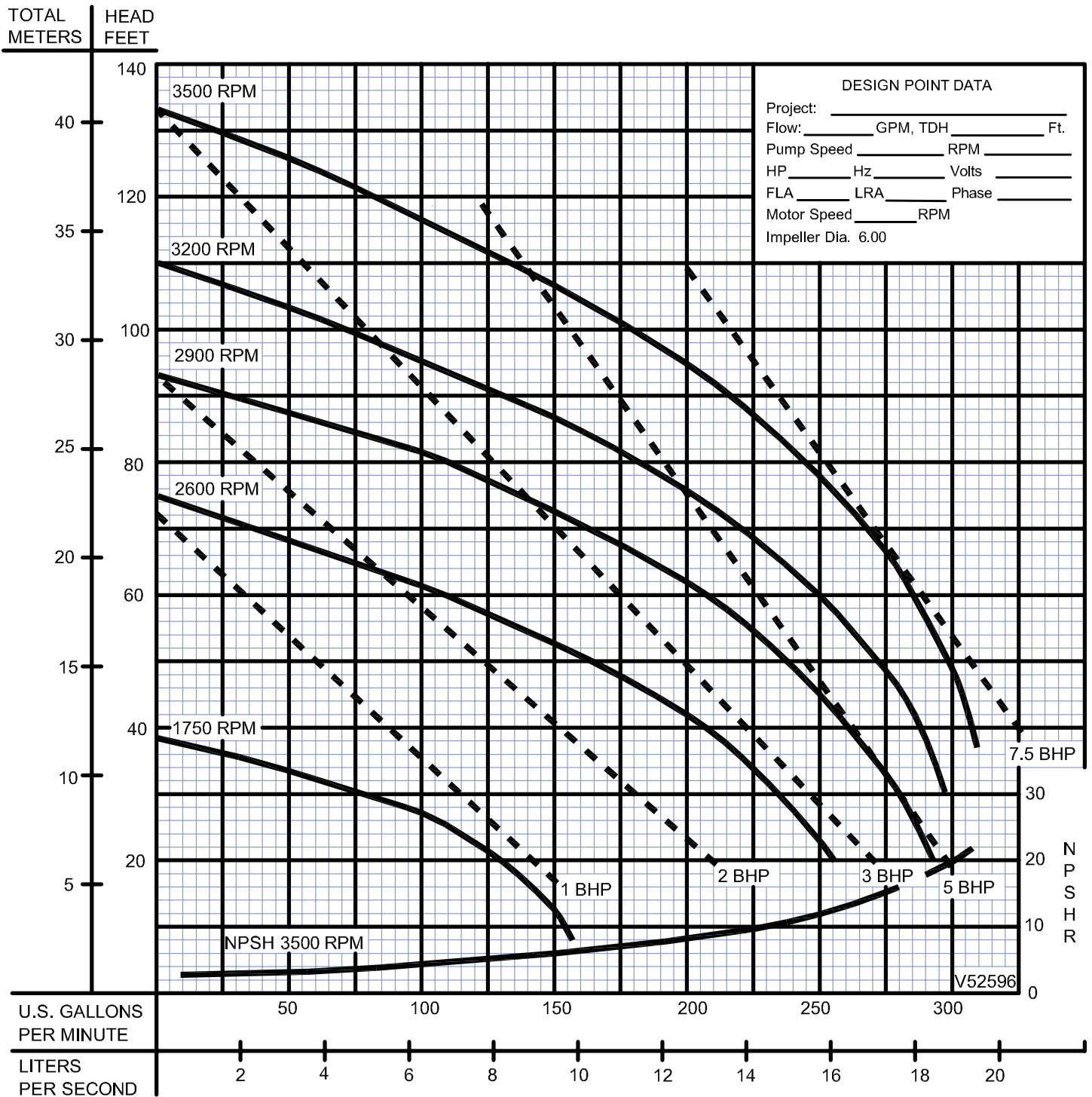

Testing is performed with water, specific gravity 1.0 @ 68° F @ (20°C), other fluids may vary performance

# Series 20ICU-1

Pump End  
3" NPT

# BARNES®

www.cranepumps.com

## Self-Priming Universal/Electric Driven

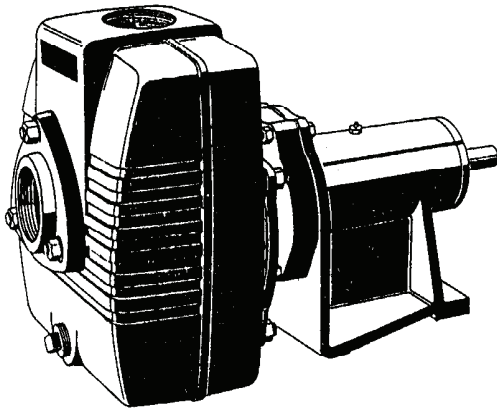

**Series: 20ICU-1**

### DESCRIPTION:

SELF-PRIMING CENTRIFUGAL PUMPS  
DESIGNED FOR MARINE, MUNICIPAL AND  
INDUSTRIAL APPLICATIONS

### Specifications:

<b>SUCTION/DISCHARGE</b> .....	3" x 3" NPT, Female
<b>LIQUID TEMPERATURE</b> .....	160°F (71°C) Continuous
<b>INTERMEDIATE</b> .....	Cast Iron ASTM A-48, Class 30
<b>VOLUTE</b> .....	Cast Iron ASTM A-48, Class 30, Removable
<b>BODY</b> .....	Cast Iron ASTM A-48, Class 30
<b>PEDESTAL</b> .....	Cast Iron ASTM A-48, Class 30
<b>IMPELLER: Design</b> .....	Open, Trash Type, Dynamically Balanced, ISO G6.3
<b>Material</b> .....	Cast Iron ASTM A-48, Class 30
<b>SHAFT</b> .....	Stainless Steel
<b>SQUARE RINGS</b> .....	Buna-N
<b>HARDWARE</b> .....	Series Stainless Steel
<b>PAINT</b> .....	Air Dry Enamel.
<b>SEAL: Design</b> .....	Single Mechanical with Lip Seal
<b>Lubrication</b> .....	Oil
<b>Material</b> .....	Rotating Faces - Carbon Stationary Faces - Ceramic Elastomer - Buna-N Hardware - 300 Series Stainless
<b>BEARING - PUMP END:</b>	
<b>Design</b> .....	Single Row, Ball
<b>Lubrication</b> .....	Grease
<b>Load</b> .....	Radial
<b>BEARING - DRIVE END:</b>	
<b>Design</b> .....	Single Row, Ball
<b>Lubrication</b> .....	Grease
<b>Load</b> .....	Radial
<b>CHECK VALVE:</b>	
<b>Material</b> .....	Valve Flap-Neoprene Weight-Cast Iron ASTM A-48, Class 30
<b>OPTIONAL EQUIPMENT</b> .....	Seal Material, Flex Coupled Assy. with Base & OSHA Guard; Right Hand V-Belt Drive Assy., Left Hand V-Belt Drive Assy., and In-Line Vertical V-Belt Drive Assy. with Base, Motor Adjusting Base and OSHA Guard.

SECTION 4E  
PAGE 28  
DATE 10/07

**CRANE**®

A Crane Co. Company

**PUMPS & SYSTEMS**

USA: (937) 778-8947 • Canada: (905) 457-6223 • International: (937) 615-3598



### Self-Priming Universal/Electric Driven

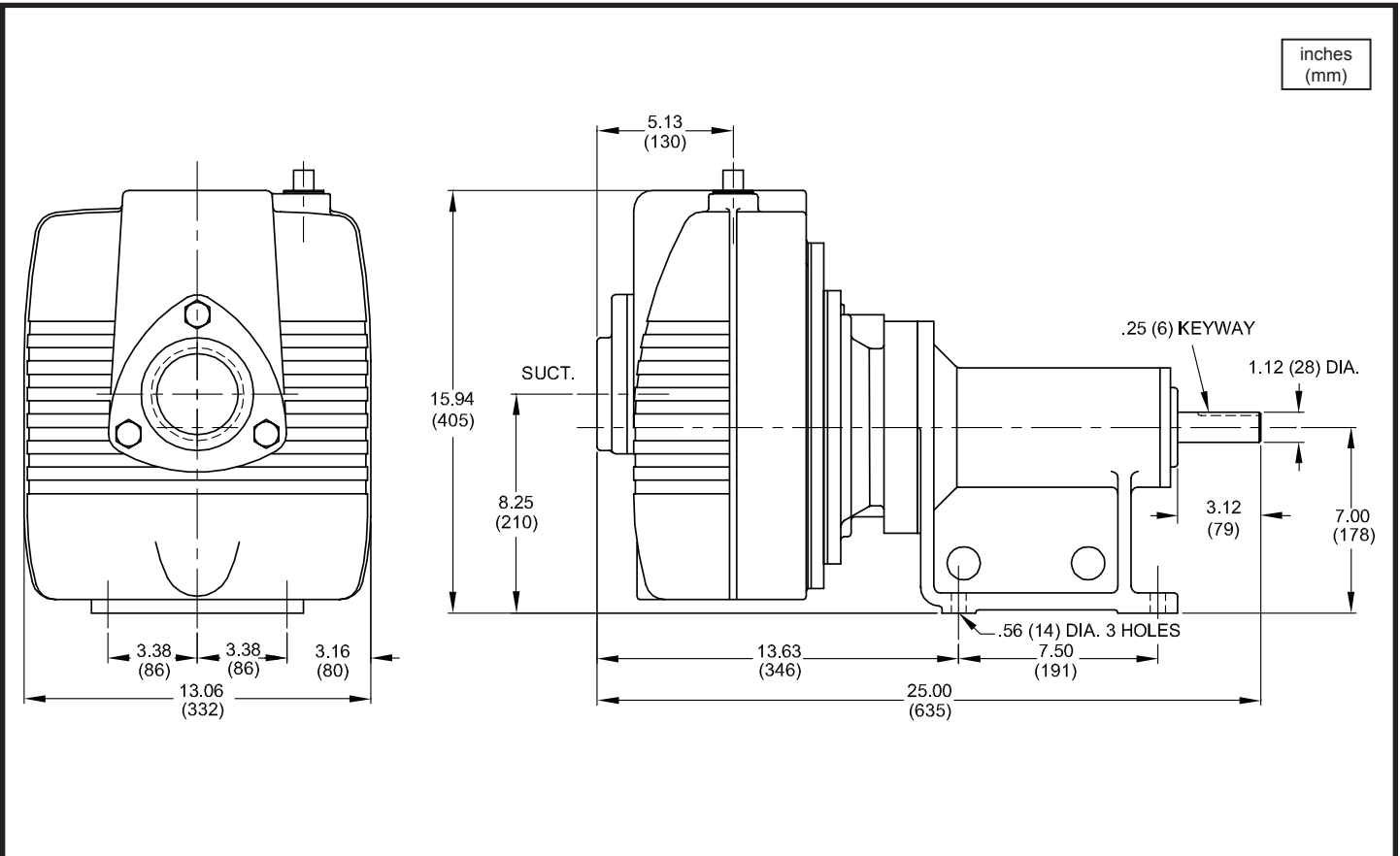

MODEL NO	PART NO	WEIGHT NET LBS (kg)
20ICU-1	052624	223 (101)

**IMPORTANT !**

- DO NOT USE FOR PUMPING FLUIDS WITH A FLASH POINT OF LESS THAN 100°F.
- MAKE CERTAIN THAT PUMP AND/OR MOTOR ASSEMBLY AND CONTROLS HAVE THE APPROPRIATE RATINGS FOR THE GIVEN APPLICATION AREA CLASSIFICATION. (ie DIVISION I, AGENCY LISTING ETC.)

# Series 20ICU-1

Performance Curve

Pump End

# BARNES®

www.cranepumps.com

## Self-Priming Universal/Electric Driven

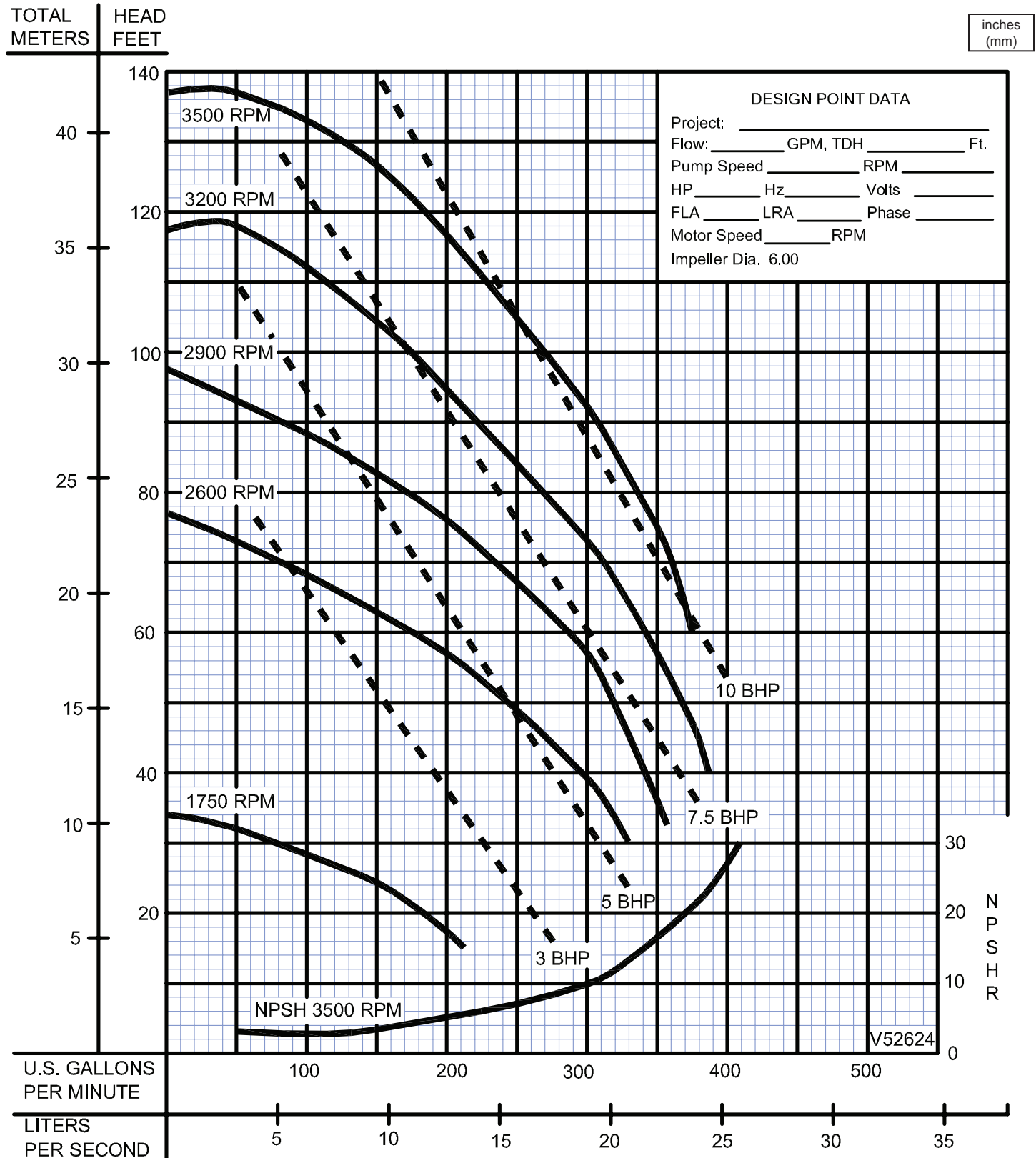

Testing is performed with water, specific gravity 1.0 @ 68° F @ (20°C), other fluids may vary performance

SECTION 4E  
PAGE 30  
DATE 5/05

**CRANE**  
A Crane Co. Company

**PUMPS & SYSTEMS**

USA: (937) 778-8947 • Canada: (905) 457-6223 • International: (937) 615-3598

### Self-Priming Universal/Electric Driven

## Specifications:

**SUCTION/DISCHARGE** .....3" x 3" NPT, Female  
**LIQUID TEMPERATURE** .....160°F (71°C) Continuous  
**INTERMEDIATE** .....Cast Iron ASTM A-48, Class 30  
**VOLUTE** .....Cast Iron ASTM A-48, Class 30,  
Removable  
**BODY** .....Cast Iron ASTM A-48, Class 30  
**PEDESTAL** .....Cast Iron ASTM A-48, Class 30  
**IMPELLER: Design** .....Open, Trash Type, Dynamically  
Balanced, ISO G6.3  
*Material* .....Cast Iron ASTM A-48, Class 30  
**SHAFT** .....Stainless Steel  
**SQUARE RINGS** .....Buna-N  
**HARDWARE** .....Series Stainless Steel  
**PAINT** .....Air Dry Enamel.  
**SEAL: Design** .....Single Mechanical with Lip Seal  
*Lubrication* .....Oil  
*Material* .....Rotating Faces - Carbon  
Stationary Faces - Ceramic  
Elastomer - Buna-N  
Hardware -300 Series Stainless

#### BEARING - PUMP END:

*Design*.....Single Row, Ball  
*Lubrication* .....Grease  
*Load*.....Radial

#### BEARING - DRIVE END:

*Design*.....Single Row, Ball  
*Lubrication* .....Grease  
*Load*.....Radial

#### CHECK VALVE:

*Material* .....Valve Flap-Neoprene  
Weight-Cast Iron ASTM A-48, Class 30

**OPTIONAL EQUIPMENT**.....Seal Material, Flex Coupled Assy. with  
Base & OSHA Guard; Right Hand V-Belt Drive Assy., Left Hand V-Belt Drive  
Assy., and In-Line Vertical V-Belt Drive Assy. with Base, Motor Adjusting  
Base and OSHA Guard.

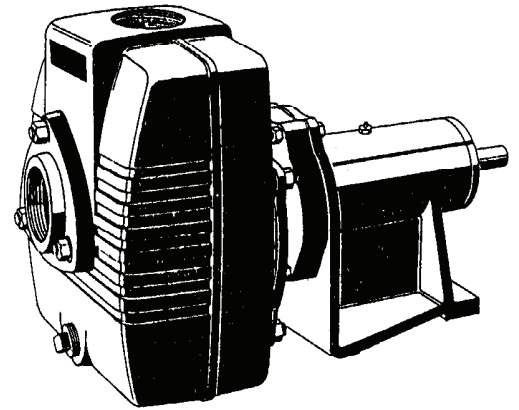

**Series: 25ICU-1**

## DESCRIPTION:

SELF-PRIMING CENTRIFUGAL PUMPS  
DESIGNED FOR MARINE, MUNICIPAL AND  
INDUSTRIAL APPLICATIONS

# Series 25ICU-1

Pump End  
3" NPT

# BARNES®

www.cranepumps.com

## Self-Priming Universal/Electric Driven

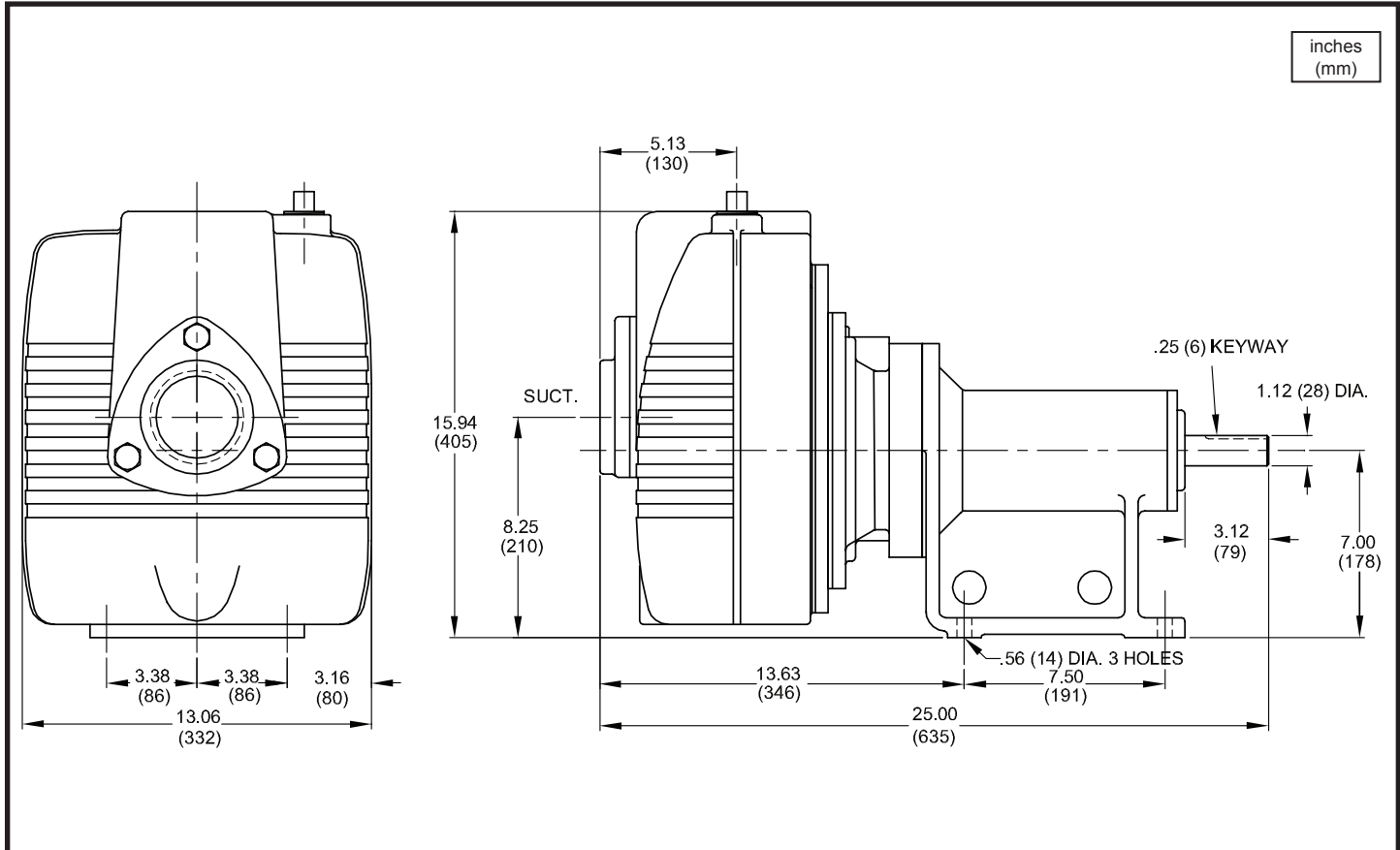

MODEL NO	PART NO	WEIGHT NET LBS (kg)	
25ICU-1	052626	236 (107)	

### IMPORTANT !

- DO NOT USE FOR PUMPING FLUIDS WITH A FLASH POINT OF LESS THAN 100°F.
- MAKE CERTAIN THAT PUMP AND/OR MOTOR ASSEMBLY AND CONTROLS HAVE THE APPROPRIATE RATINGS FOR THE GIVEN APPLICATION AREA CLASSIFICATION. (ie DIVISION I, AGENCY LISTING ETC.)

SECTION 4E  
PAGE 32  
DATE 5/05

## CRANE®

A Crane Co. Company

## PUMPS & SYSTEMS

USA: (937) 778-8947 • Canada: (905) 457-6223 • International: (937) 615-3598

### Self-Priming Universal/Electric Driven

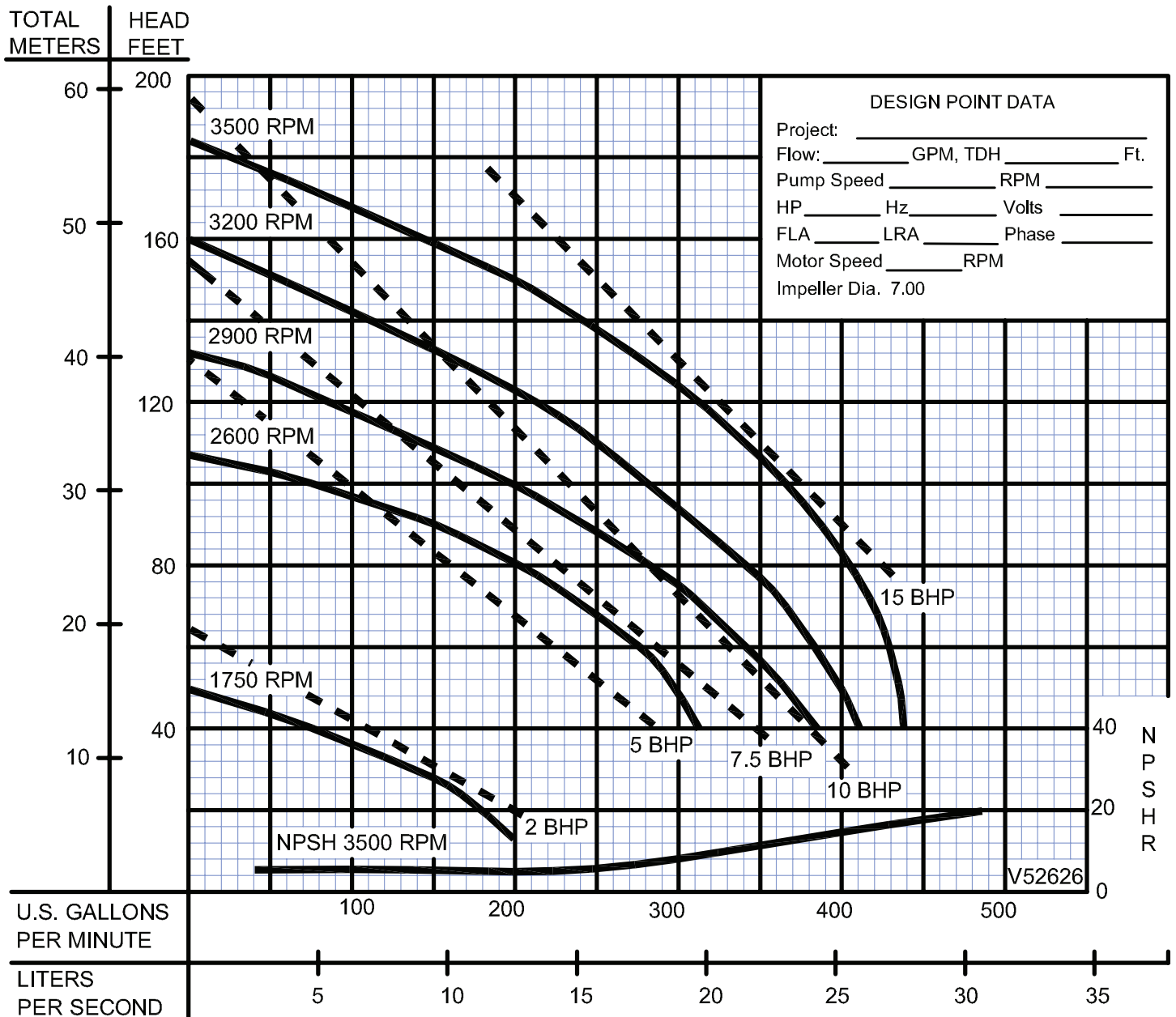

Testing is performed with water, specific gravity 1.0 @ 68° F @ (20°C), other fluids may vary performance

**Self-Priming Universal/Electric Driven**

This page intentionally left blank

This page intentionally left blank

**Self-Priming Universal/Electric Driven**

This page intentionally left blank



This page intentionally left blank

**Self-Priming Universal/Electric Driven**

This page intentionally left blank

This page intentionally left blank

# Series TS7

Pump End  
1½" NPT



## Self-Priming Universal/Electric Driven

### Specifications:

<b>SUCTION/DISCHARGE</b> .....	1½" x 1½" NPT, Female
<b>LIQUID TEMPERATURE</b> .....	160°F (71°C) Continuous
<b>VOLUTE/WEARPLATE</b> .....	Cast Iron ASTM A-48, Class 30, Replaceable, Multi-Stage
<b>CASE</b> .....	Cast Iron ASTM A-48, Class 30
<b>PEDESTAL</b> .....	Cast Iron ASTM A-48, Class 30
<b>IMPELLER: Design</b> .....	Semi-Open on Both Sides, Passes 1/4" Solids. Dynamically Balanced, ISO G6.3
<i>Material</i> .....	Cast Iron ASTM A-48, Class 30
<b>SHAFT</b> .....	Stainless Steel
<b>SHAFT SLEEVE</b> .....	316 Stainless Steel
<b>SQUARE RINGS</b> .....	Buna-N
<b>HARDWARE</b> .....	Corrosion Resistant Steel
<b>PAINT</b> .....	Air Dry Enamel.
<b>SEAL:</b>	
<i>Design</i> .....	Single Mechanical
<i>Lubrication</i> .....	Grease, with Self-Feeding Lubricator
<i>Material</i> .....	Rotating Faces - Carbon Stationary Faces - Ceramic Elastomer - Buna-N Hardware - 300 Series Stainless
<b>BEARING - PUMP END:</b>	
<i>Design</i> .....	Single Row, Ball
<i>Lubrication</i> .....	Oil
<i>Load</i> .....	Radial & Thrust
<b>BEARING - DRIVE END:</b>	
<i>Design</i> .....	Single Row, Ball
<i>Lubrication</i> .....	Oil
<i>Load</i> .....	Radial & Thrust
<b>CHECK VALVE:</b>	
<i>Material</i> .....	Valve Flap-Neoprene Weight-Cast Iron ASTM A-48, Class 30
<b>OPTIONAL EQUIPMENT</b> .....	Seal Material, Case Heater, Stainless Hardware; High Temperature Control; Flex Coupled Assy., with Base & OSHA Guard; Right Hand V-Belt Drive Assy., Left Hand V-Belt Drive Assy., and In-Line Vertical V-Belt Drive Assy., with Base, Motor Adjusting Base & OSHA Guard.

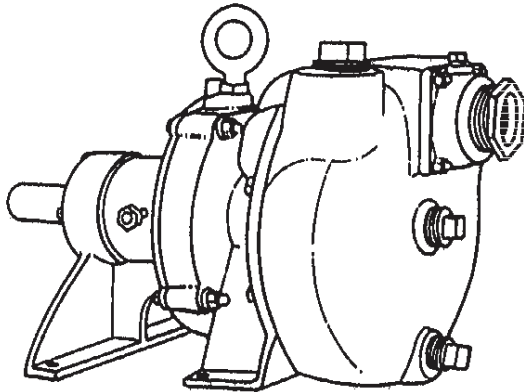

**Series: TS7**

### DESCRIPTION:

SELF-PRIMING CENTRIFUGAL PUMPS  
DESIGNED FOR MARINE, MUNICIPAL AND  
INDUSTRIAL APPLICATIONS

SECTION 4E  
PAGE 40  
DATE 10/07

**CRANE**<sup>®</sup>

A Crane Co. Company

**PUMPS & SYSTEMS**

USA: (937) 778-8947 • Canada: (905) 457-6223 • International: (937) 615-3598

## Self-Priming Universal/Electric Driven

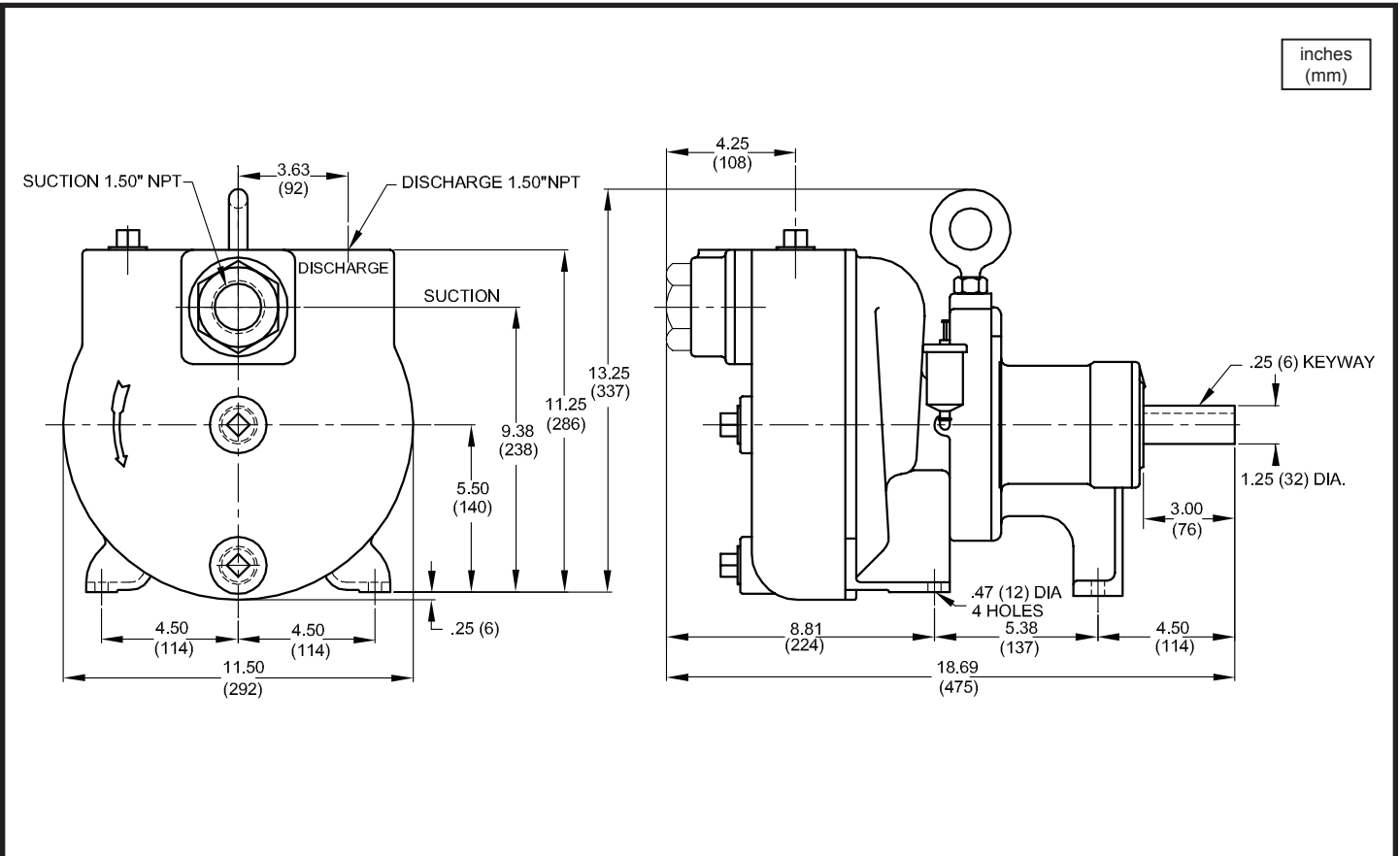

MODEL NO	PART NO	WEIGHT NET LBS (kg)	
TS7	1C25D-0006B-001	125 (57)	

**IMPORTANT !**

- DO NOT USE FOR PUMPING FLUIDS WITH A FLASH POINT OF LESS THAN 100°F.
- MAKE CERTAIN THAT PUMP AND/OR MOTOR ASSEMBLY AND CONTROLS HAVE THE APPROPRIATE RATINGS FOR THE GIVEN APPLICATION AREA CLASSIFICATION. (ie DIVISION I, AGENCY LISTING ETC.)

# Series TS7

Performance Curve

Pump End



## Self-Priming Universal/Electric Driven

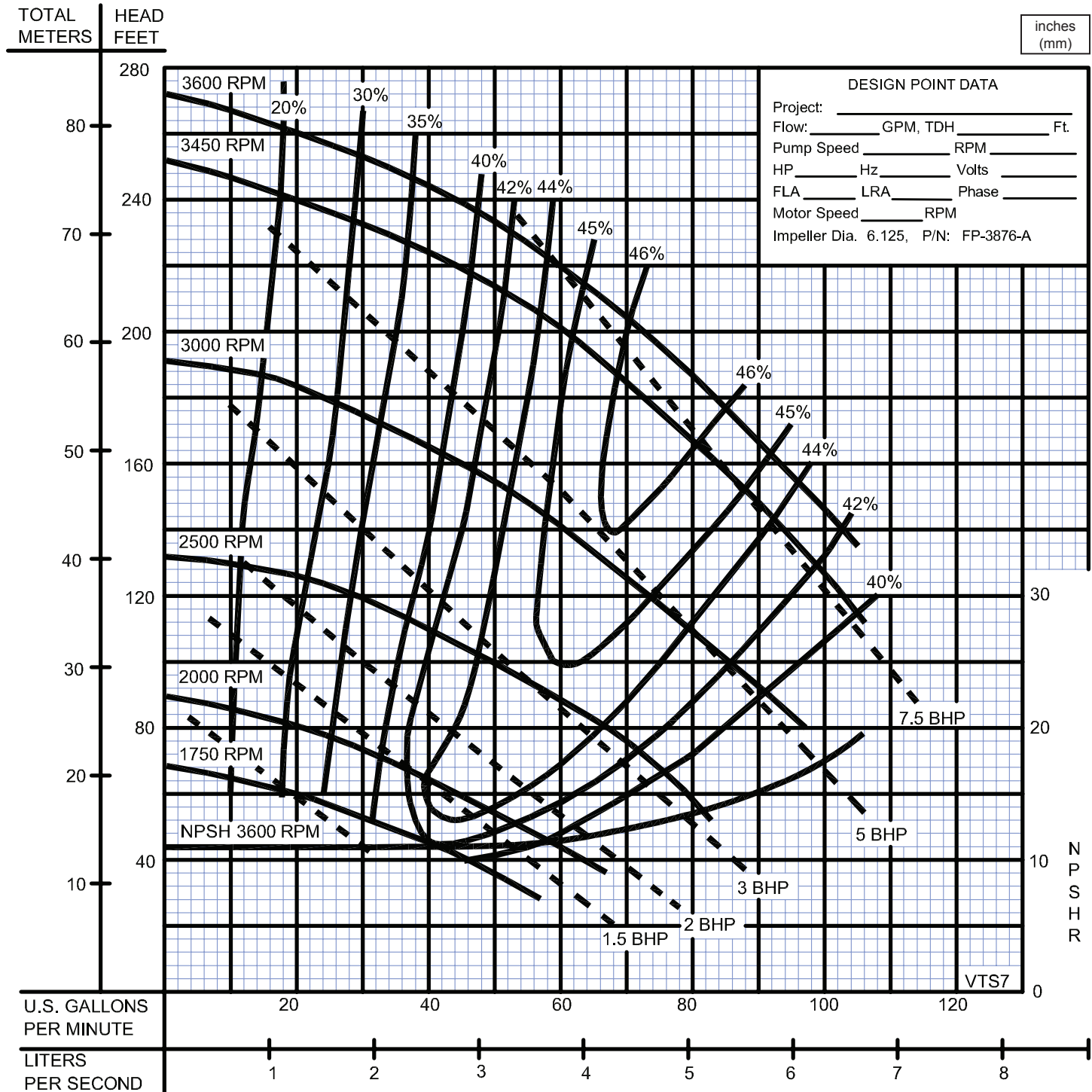

Testing is performed with water, specific gravity 1.0 @ 68° F @ (20°C), other fluids may vary performance

SECTION 4E  
PAGE 42  
DATE 5/05



PUMPS & SYSTEMS

A Crane Co. Company

USA: (937) 778-8947 • Canada: (905) 457-6223 • International: (937) 615-3598

## Self-Priming Universal/Electric Driven

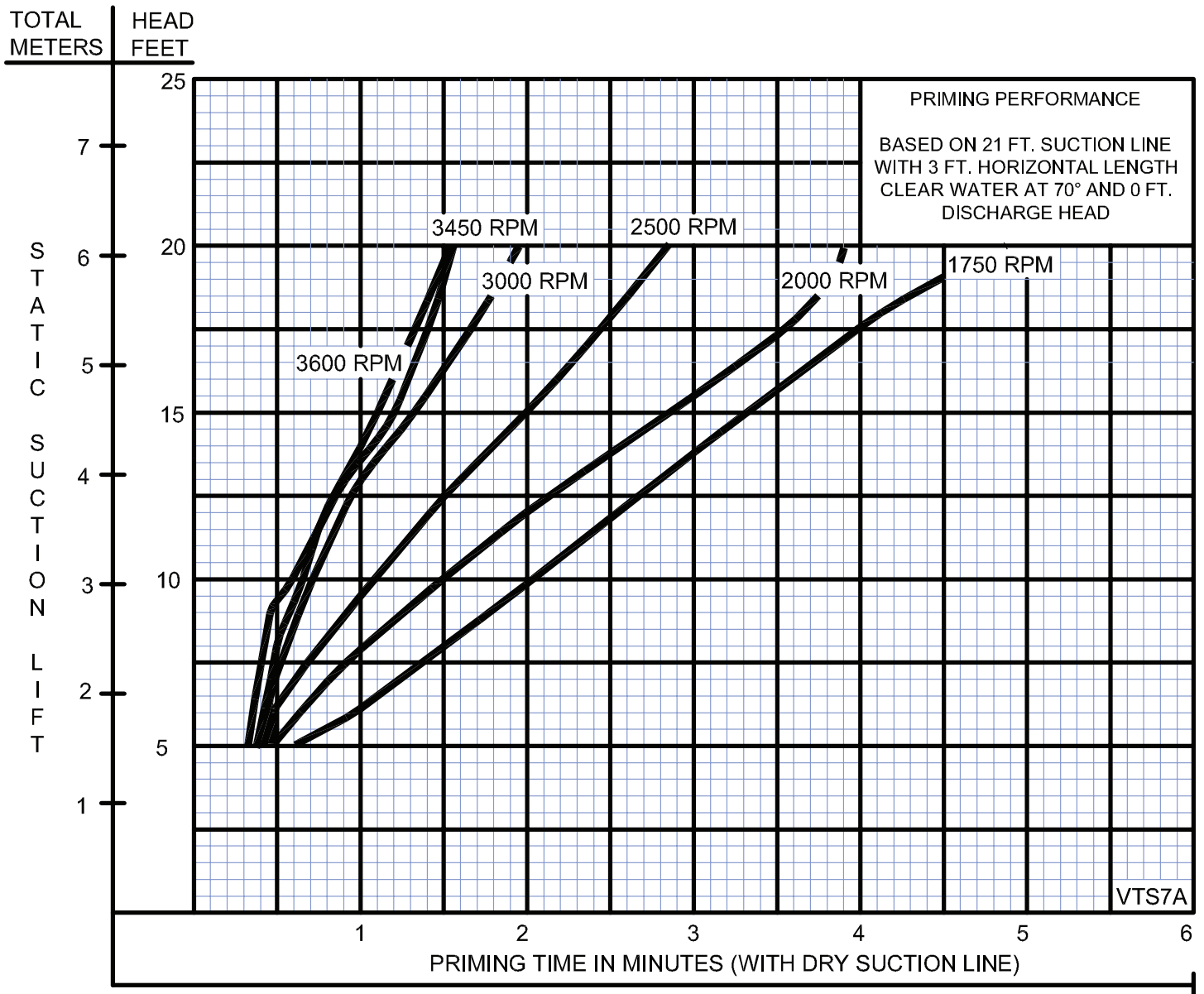

**Self-Priming Universal/Electric Driven**

This page intentionally left blank



**Self-Priming Universal/Electric Driven**

**Specifications:**

**SUCTION/DISCHARGE**..... 2" X 2" NPT Female  
**LIQUID TEMPERATURE** .....160°F (71°C) Continuous  
**VOLUTE/WEARPLATE** .....Cast Iron ASTM A-48, Class 30,  
 Replaceable  
**CASE**.....Cast Iron ASTM A-48, Class 30,  
**PEDESTAL**.....Cast Iron ASTM A-48, Class 30  
**IMPELLER: Design** ..... Open Type, Passes 1/4" Solids  
**Material** .....Cast Iron ASTM A-48, Class 30  
 Dynamically Balanced, ISO G6.3  
**IMPELLER SHAFT** .....Steel, Stress Proof  
**LOCKING COLLAR**.....Stainless Steel. Serves as Shaft Slinger  
**SQUARE RINGS** .....Buna-N  
**HARDWARE** .....Corrosion Resistant Steel  
**PAINT** .....Air Dry Enamel  
**SEAL:**  
*Design* .....Single Mechanical  
*Lubrication* .....Grease, with Self-Feeding Lubricator  
*Material* .....Rotating Faces - Carbon  
 Stationary Faces - Ceramic  
 Elastomer - Buna-N  
 Hardware - 300 Series Stainless  
**BEARING:**  
*Design*.....Single Row, Ball  
*Lubrication* .....Grease  
*Load*.....Radial & Thrust  
**CHECK VALVE:**  
*Material* .....Valve Flap-Neoprene  
 Weight-Cast Iron ASTM A-48, Class 30  
**OPTIONAL EQUIPMENT**.....Seal Material, Case Heater, Stainless  
 Hardware; High Temperature Control; Flex Coupled Assy., with Base &  
 OSHA Guard; Right Hand V-Belt Drive Assy., Left Hand V-Belt Drive Assy.,  
 and In-Line Vertical V-Belt Drive Assy., with Base, Motor Adjusting Base &  
 OSHA Guard.

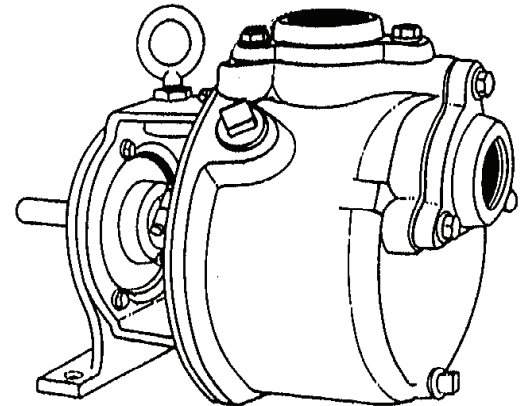

**Series: BH7**

**DESCRIPTION:**

SELF-PRIMING CENTRIFUGAL PUMPS  
 DESIGNED FOR MARINE, MUNICIPAL AND  
 INDUSTRIAL APPLICATIONS

# Series BH7

Pump End  
2" NPT



## Self-Priming Universal/Electric Driven

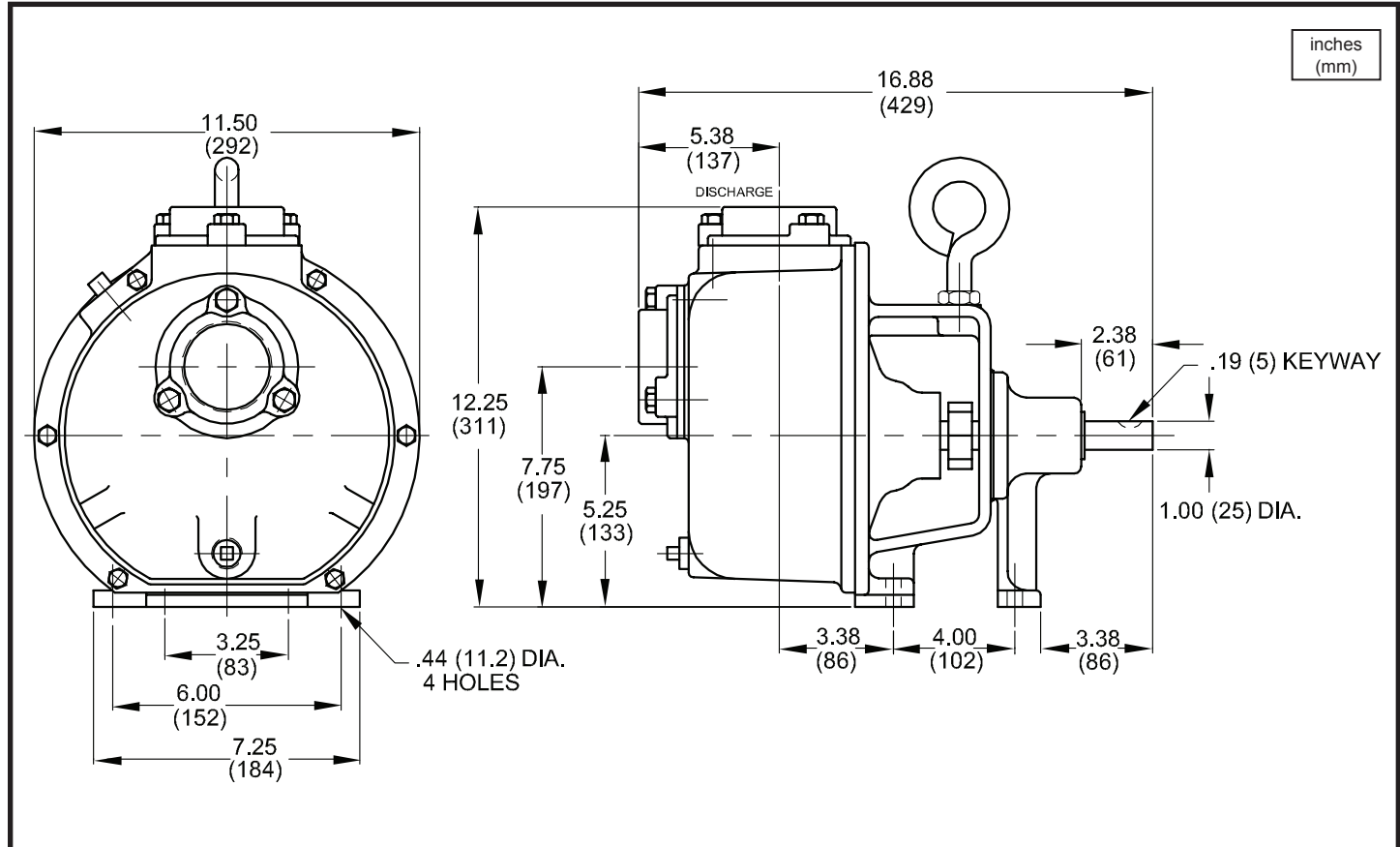

MODEL NO	PART NO	WEIGHT NET LBS (kg)	
BH7	2C0UD-0006D-001	93 (42)	

### IMPORTANT !

- DO NOT USE FOR PUMPING FLUIDS WITH A FLASH POINT OF LESS THAN 100°F.
- MAKE CERTAIN THAT PUMP AND/OR MOTOR ASSEMBLY AND CONTROLS HAVE THE APPROPRIATE RATINGS FOR THE GIVEN APPLICATION AREA CLASSIFICATION. (ie DIVISION I, AGENCY LISTING ETC.)

SECTION 4E  
PAGE 46  
DATE 2/11



A Crane Co. Company

## PUMPS & SYSTEMS

USA: (937) 778-8947 • Canada: (905) 457-6223 • International: (937) 615-3598

## Self-Priming Universal/Electric Driven

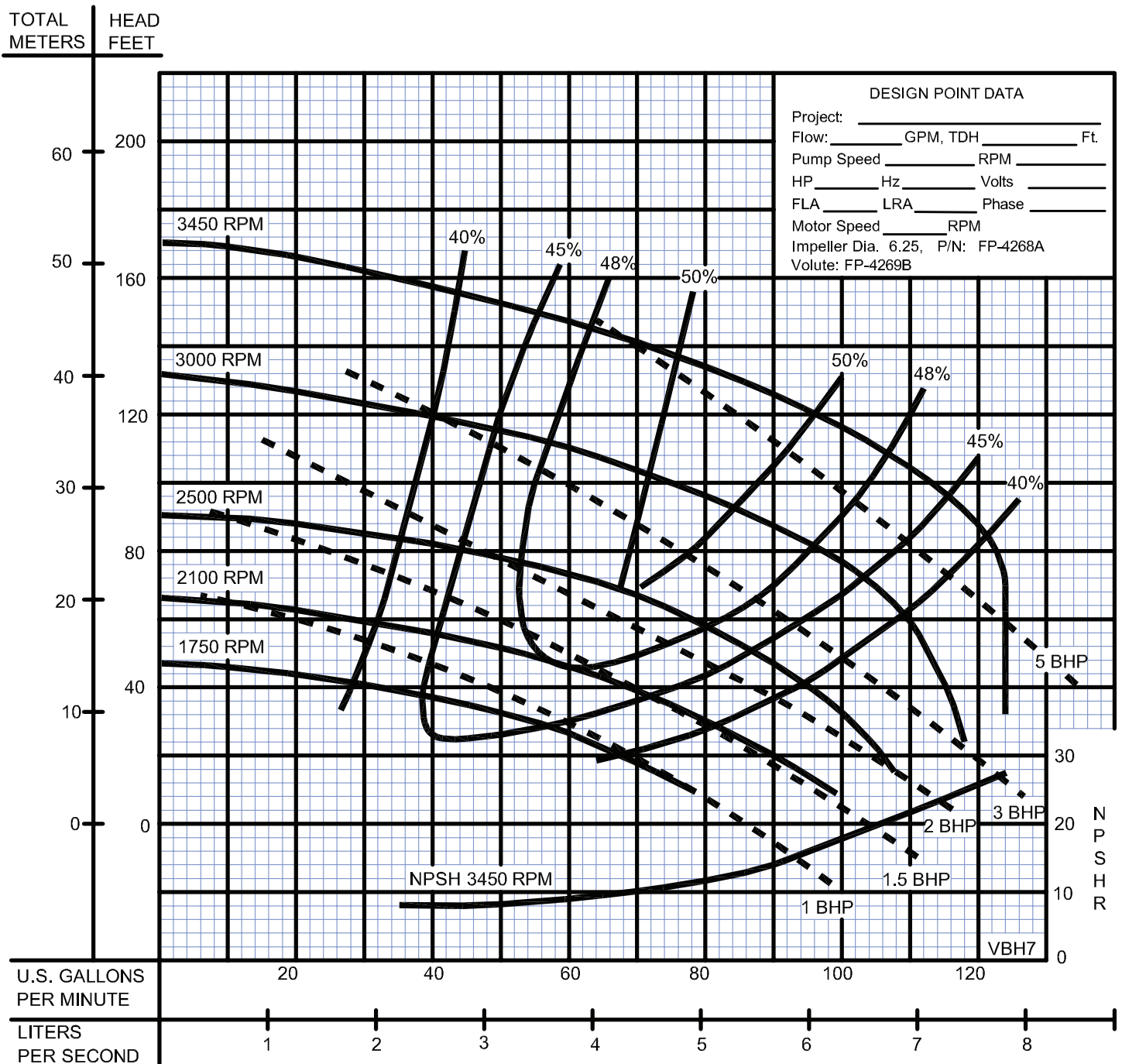

Testing is performed with water, specific gravity 1.0 @ 68° F @ (20°C), other fluids may vary performance

# Model: BH7

Horizontal V-Belt Base, Motor Speed: **1750 RPM**  
 V-Belt Drive, Sheaves & Bushings, Pump Shaft: **1.00 Dia.**



## Self-Priming Universal/Electric Driven

Driven Speed	Speed Ratio	Motor HP	Frame Size	Center Distance	Drive P/N		Driven Speed	Speed Ratio	Motor HP	Frame Size	Center Distance	Drive P/N
3450	1.97	10.0	215T	14.7	091348		2200	1.25	3.0	182-184T	14.8	091376
3450	1.97	7.5	213-214T	14.7	091349		2200	1.25	2.0	182T	14.8	091376
							2200	1.25	2.0	145T	14.8	091377
3300	1.89	10.0	215T	15.4	091350							
3300	1.89	7.5	213-214T	15.4	091350		2100	1.20	3.0	182-184T	15.2	091378
							2100	1.20	2.0	182T	15.2	091379
3200	1.83	10.0	215T	15.1	091351		2100	1.20	2.0	145T	15.2	091380
3200	1.83	7.5	213-214T	15.1	091352							
							2000	1.14	3.0	182-184T	15.1	091381
3100	1.77	10.0	215T	14.7	091353		2000	1.14	2.0	182T	15.3	091382
3100	1.77	7.5	213-214T	14.7	091353		2000	1.14	2.0	145T	15.3	091383
3100	1.77	5.0	213T	14.7	091354		2000	1.14	1.5	145T	15.3	091383
3100	1.77	5.0	184T	14.7	091355							
							1900	1.09	3.0	182-184T	14.5	091384
3000	1.70	7.5	213-214T	15.4	091356		1900	1.09	2.0	182T	14.5	091385
3000	1.70	5.0	213T	15.4	091356		1900	1.09	2.0	145T	14.5	091386
3000	1.70	5.0	184T	15.4	091357		1900	1.09	1.5	145T	14.5	091386
2900	1.66	7.5	213-214T	14.9	091358		1750	1.0	2.0	182T	15.1	091387
2900	1.66	5.0	213T	14.9	091358		1750	1.0	2.0	145T	15.1	091388
2900	1.66	5.0	184T	14.9	091359		1750	1.0	1.5	145T	15.1	091388
							1750	1.0	1.0	143T	15.1	091388
2800	1.60	7.5	213-214T	15.7	091360							
2800	1.60	5.0	213T	15.7	091360							
2800	1.60	5.0	184T	15.7	091361							
2700	1.55	7.5	213-214T	15.2	091362							
2700	1.55	5.0	213T	15.2	091362							
2700	1.55	5.0	184T	15.2	091363							
2600	1.49	7.5	213-214T	14.7	091364							
2600	1.49	5.0	213T	14.7	091364							
2600	1.49	5.0	184T	14.7	091365							
2600	1.49	3.0	182-184T	14.7	091366							
2500	1.43	5.0	213T	14.9	091367							
2500	1.43	5.0	184T	14.9	091368							
2500	1.43	3.0	182-184T	14.9	091369							
2400	1.37	5.0	213T	15.7	091370							
2400	1.37	5.0	184T	15.7	091371							
2400	1.37	3.0	182-184T	15.7	091372							
2300	1.31	5.0	213T	15.5	091373							
2300	1.31	5.0	184T	15.5	091374							
2300	1.31	3.0	182-184T	14.6	091375							



# Model: BH7

Horizontal V-Belt Base, Motor Speed: **3450 RPM**  
 V-Belt Drive, Sheaves & Bushings, Pump Shaft: **1.00 Dia.**

## Self-Priming Universal/Electric Driven

Driven Speed	Speed Ratio	Motor HP	Frame Size	Center Distance	Drive P/N		Driven Speed	Speed Ratio	Motor HP	Frame Size	Center Distance	Drive P/N
3450	1.00	10.0	215T	14.8	091389		2200	1.57	3.0	182-184T	14.7	091421
3450	1.00	7.5	213-214T	14.8	091389		2200	1.57	2.0	182T	14.7	091422
							2200	1.57	2.0	145T	14.7	091323
3300	1.05	10.0	215T	14.8	091390							
3300	1.05	7.5	213-214T	14.8	091390		2100	1.62	3.0	182-184T	15.5	091424
							2100	1.62	2.0	182T	15.5	091424
3200	1.07	10.0	215T	14.9	091391		2100	1.62	2.0	145T	15.5	091425
3200	1.07	7.5	213-214T	14.9	091392							
							2000	1.71	3.0	182-184T	15.3	091426
3100	1.11	10.0	215T	15.0	091393		2000	1.71	2.0	182T	15.3	091426
3100	1.11	7.5	213-214T	15.0	091393		2000	1.71	2.0	145T	15.3	091427
3100	1.11	5.0	213T	15.0	091394		2000	1.71	1.5	145T	15.3	091427
3100	1.11	5.0	184T	15.0	091395							
							1900	1.80	3.0	182-184T	15.1	091428
3000	1.15	7.5	213-214T	15.5	091396		1900	1.80	2.0	182T	15.1	091428
3000	1.15	5.0	213T	15.5	091397		1900	1.80	2.0	145T	15.1	091429
3000	1.15	5.0	184T	15.5	091398		1900	1.80	1.5	145T	15.1	091429
2900	1.19	7.5	213-214T	14.8	091399		1750	1.95	2.0	182T	14.7	091430
2900	1.19	5.0	213T	14.8	091400		1750	1.95	2.0	145T	14.7	091431
2900	1.19	5.0	184T	14.8	091401		1750	1.95	1.5	145T	14.7	091431
							1750	1.95	1.0	143T	14.7	091431
2800	1.23	7.5	213-214T	15.3	091402							
2800	1.23	5.0	213T	15.3	091403							
2800	1.23	5.0	184T	15.3	091404							
2700	1.28	7.5	213-214T	15.3	091405							
2700	1.28	5.0	213T	15.3	091406							
2700	1.28	5.0	184T	15.3	091407							
2600	1.31	7.5	213-214T	15.5	091408							
2600	1.31	5.0	213T	14.9	091409							
2600	1.31	5.0	184T	14.9	091410							
2600	1.31	3.0	182-184T	14.9	091411							
2500	1.38	5.0	213T	14.4	091412							
2500	1.38	5.0	184T	14.4	091413							
2500	1.38	3.0	182-184T	14.4	091414							
2400	1.44	5.0	213T	15.2	091415							
2400	1.44	5.0	184T	15.2	091416							
2400	1.44	3.0	182-184T	15.2	091417							
2300	1.49	5.0	213T	14.6	091418							
2300	1.49	5.0	184T	14.6	091419							
2300	1.49	3.0	182-184T	14.6	091420							

**Self-Priming Universal/Electric Driven**

This page intentionally left blank

**Self-Priming Universal/Electric Driven**

**Specifications:**

**SUCTION/DISCHARGE**..... 3" (76mm) x 3" (76mm) 125lb. Flange  
**LIQUID TEMPERATURE** .....160°F (71°C) Continuous  
**VOLUTE/WEARPLATE** .....Cast Iron ASTM A-48, Class 30,  
 Replaceable, External Clearance Adjustment  
**CASE**.....Cast Iron ASTM A-48, Class 30  
**END COVER** .....Cast Iron ASTM A-48, Class 30  
**SEAL PLATE** .....Alloy Steel, Replaceable  
**PEDESTAL**.....Cast Iron ASTM A-48, Class 30  
**IMPELLER: Design** .....Semi-Open Type, Passes 3/4" Solids  
**Material** .....Cast Iron ASTM A-48, Class 30  
 Dynamically Balanced, ISO G6.3  
**IMPELLER SHAFT** .....Steel  
**SQUARE RINGS** .....Buna-N  
**HARDWARE** .....Corrosion Resistant Steel  
**PAINT** .....Air Dry Enamel  
**SEAL Design** .....Single Mechanical  
**Lubrication** .....Grease, with Self-Feeding Lubricator  
**Material** .....Rotating Faces - Carbon  
 Stationary Faces - Ceramic  
 Elastomer - Buna-N  
 Hardware - 300 Series Stainless

**BEARING - PUMP END**  
**Design**.....Single Row, Ball  
**Lubrication** .....Oil  
**Load**.....Radial & Thrust

**BEARING - DRIVE END**  
**Design**.....Single Row, Ball  
**Lubrication** .....Oil  
**Load**.....Radial & Thrust

**CHECK VALVE:**  
**Material** .....Valve Flap-Neoprene  
 Weight-Cast Iron ASTM A-48, Class 30

**OPTIONAL EQUIPMENT**.....Seal Material, Case Heater, Stainless  
 Hardware; High Temperature Control; Flex Coupled Assy., with Base &  
 OSHA Guard; Right Hand V-Belt Drive Assy., Left Hand V-Belt Drive Assy.,  
 and In-Line Vertical V-Belt Drive Assy., with Base, Motor Adjusting Base &  
 OSHA Guard.

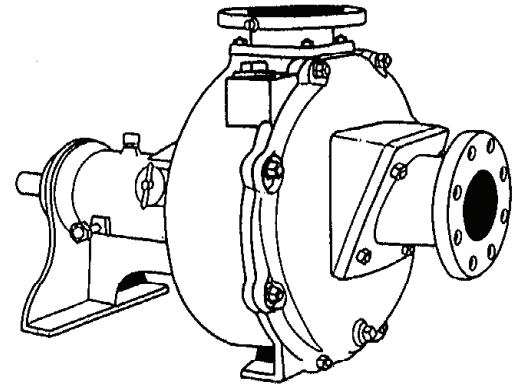

**Series: B30**

**DESCRIPTION:**

SELF-PRIMING CENTRIFUGAL PUMPS  
 DESIGNED FOR MARINE, MUNICIPAL AND  
 INDUSTRIAL APPLICATIONS

# Series B30

Pump End  
3" Flange



## Self-Priming Universal/Electric Driven

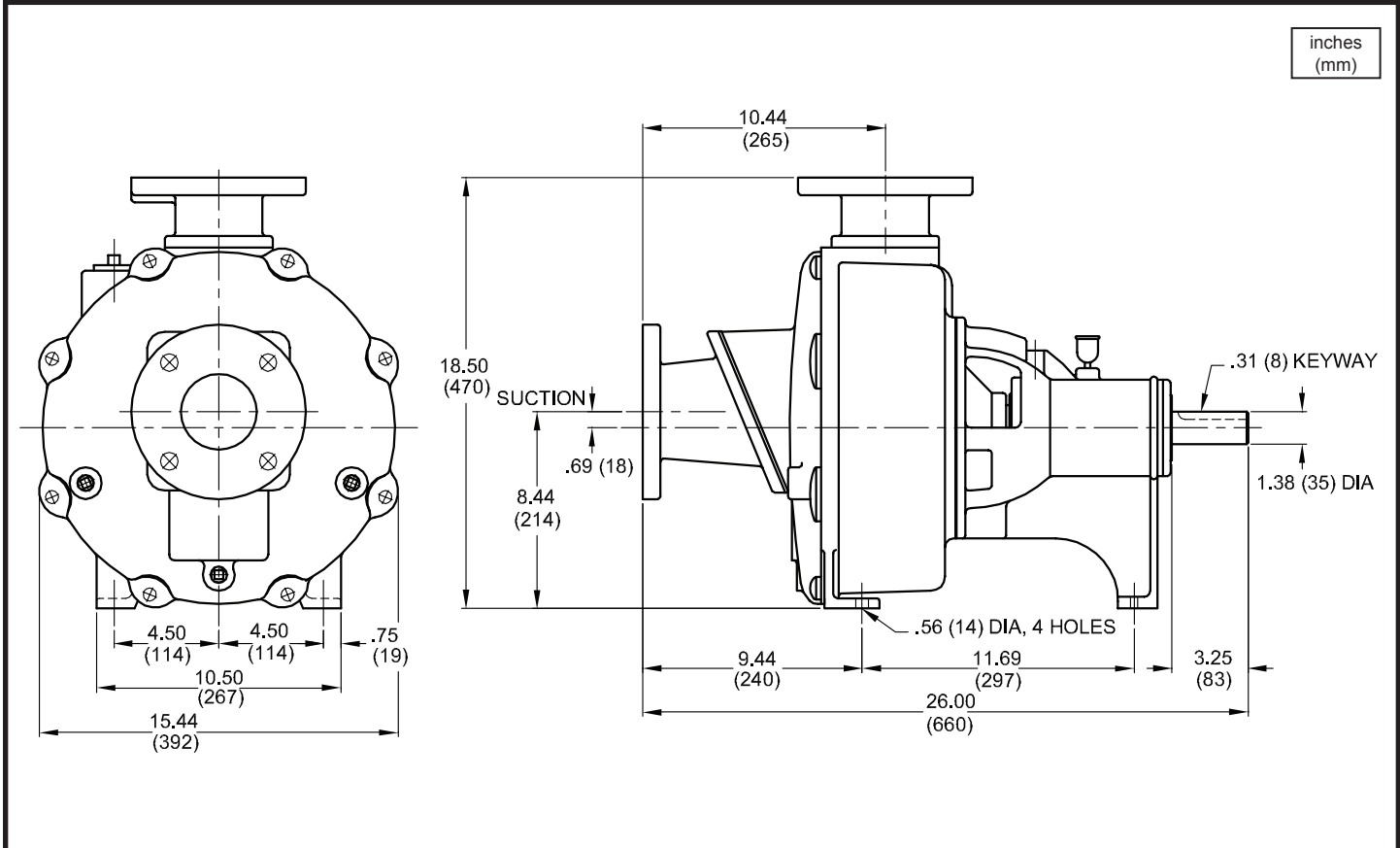

MODEL NO	PART NO	WEIGHT NET LBS (kg)	
B30	3COXD-0007X-001	220 (100)	

### IMPORTANT !

- DO NOT USE FOR PUMPING FLUIDS WITH A FLASH POINT OF LESS THAN 100°F.
- MAKE CERTAIN THAT PUMP AND/OR MOTOR ASSEMBLY AND CONTROLS HAVE THE APPROPRIATE RATINGS FOR THE GIVEN APPLICATION AREA CLASSIFICATION. (ie DIVISION I, AGENCY LISTING ETC.)

SECTION 4E  
PAGE 52  
DATE 5/05

**CRANE**  
A Crane Co. Company

**PUMPS & SYSTEMS**

USA: (937) 778-8947 • Canada: (905) 457-6223 • International: (937) 615-3598



## Self-Priming Universal/Electric Driven

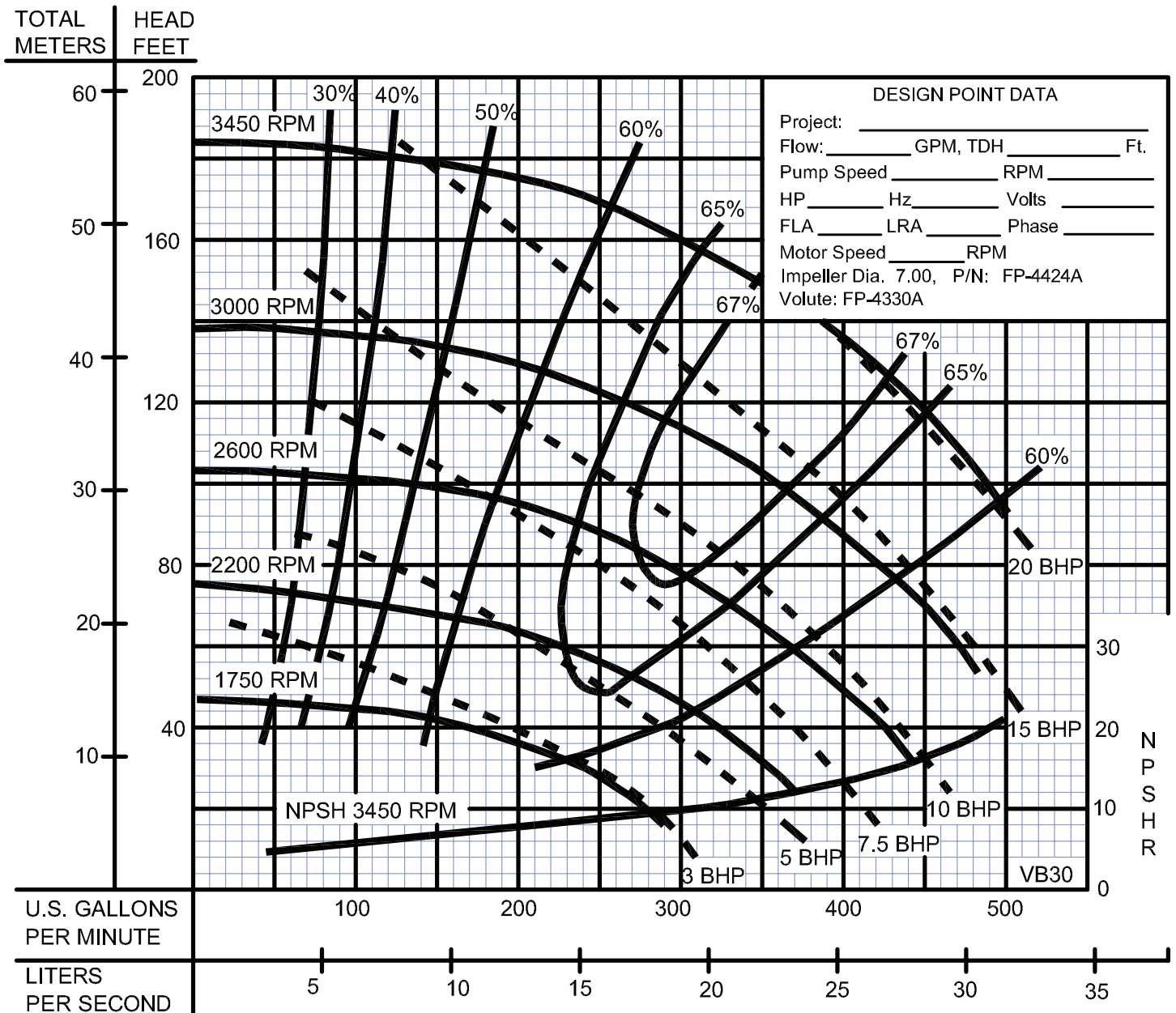

Testing is performed with water, specific gravity 1.0 @ 68° F @ (20°C), other fluids may vary performance

# Series B30

Horizontal V-Belt Base, Motor Speed: **1750 RPM**  
 V-Belt Drive, Sheaves & Bushings, Pump Shaft: **1.37 Dia.**



## Self-Priming Universal/Electric Driven

Driven Speed	Speed Ratio	Motor HP	Frame Size	Center Distance	Drive P/N		Driven Speed	Speed Ratio	Motor HP	Frame Size	Center Distance	Drive P/N
3450	1.97	30	286T	18.4	091432		2400	1.37	15	254T	19.1	091465
3450	1.97	25	284T	18.4	091432		2400	1.37	10	215T	19.1	091466
3450	1.97	20	256T	20.2	091433		2400	1.37	7.5	213-215T	19.1	091466
3450	1.97	15	254T	20.2	091434							
							2300	1.31	15	254T	18.4	091467
3300	1.89	30	286T	18.6	091435		2300	1.31	10	215T	18.4	091468
3300	1.89	25	284T	18.6	091435		2300	1.31	7.5	213-215T	18.4	091469
3300	1.89	20	256T	19.7	091436		2300	1.31	5	213T	18.4	091469
3300	1.89	15	254T	19.7	091437		2300	1.31	5	184T	18.4	091470
3272	1.87	30	286T	19.3	091438		2200	1.25	15	254T	18.6	091471
3272	1.87	25	284T	19.3	091439		2200	1.25	10	215T	18.6	091472
3272	1.87	20	256T	19.3	091440		2200	1.25	7.5	213-215T	18.6	091472
3150	1.80	15	254T	19.1	091441		2200	1.25	5	213T	18.6	091473
							2200	1.25	5	184T	18.6	091474
3100	1.77	30	286T	18.3	091442							
3100	1.77	25	284T	18.3	091442		2100	1.20	15	254T	19.4	091475
3100	1.77	20	256T	18.3	091443		2100	1.20	10	215T	19.4	091476
3100	1.77	15	254T	18.3	091443		2100	1.20	7.5	213-215T	19.4	091476
							2100	1.20	5	213T	19.4	091477
							2100	1.20	5	184T	19.4	091478
3000	1.71	25	284T	19.9	091444							
3000	1.71	20	256T	19.9	091445							
3000	1.71	15	254T	19.9	091446		2000	1.14	7.5	213-215T	19.5	091479
3000	1.71	10	215T	19.9	091447		2000	1.14	5	213T	19.5	091479
							2000	1.14	5	184T	19.5	091480
							2000	1.14	3	182-184T	19.5	091481
2900	1.66	25	284T	18.0	091448							
2900	1.66	20	256T	18.0	091449							
2900	1.66	15	254T	18.0	091450		1900	1.09	7.5	213-215T	19.7	091482
2900	1.66	10	215T	18.0	091451		1900	1.09	5	213T	19.7	091482
							1900	1.09	5	184T	19.7	091483
							1900	1.09	3	182-184T	19.7	091484
2800	1.60	25	284T	19.7	091452							
2800	1.60	20	256T	19.7	091453							
2800	1.60	15	254T	19.7	091454		1750	1.00	5	213T	19.7	091485
2800	1.60	10	215T	19.7	091455		1750	1.00	5	184T	19.7	091486
							1750	1.00	3	182-184T	19.7	091487
2700	1.55	25	284T	19.0	091456							
2700	1.55	20	256T	19.0	091457							
2700	1.55	15	254T	19.0	091457							
2700	1.55	10	215T	19.0	091458							
2700	1.55	7.5	213-215T	19.0	091458							
2600	1.49	15	254T	19.5	091459							
2600	1.49	10	215T	19.5	091460							
2600	1.49	7.5	213-215T	19.5	091461							
2500	1.43	15	254T	19.3	091462							
2500	1.43	10	215T	19.3	091463							
2500	1.43	7.5	213-215T	19.3	091464							



# Series B30

Horizontal V-Belt Base, Motor Speed: **3450 RPM**  
 V-Belt Drive, Sheaves & Bushings, Pump Shaft: **1.37 Dia.**

## Self-Priming Universal/Electric Driven

Driven Speed	Speed Ratio	Motor HP	Frame Size	Center Distance	Drive P/N		Driven Speed	Speed Ratio	Motor HP	Frame Size	Center Distance	Drive P/N
3450	1.00	30	286T	19.2	091488		2400	1.44	15	254T	19.0	091518
3450	1.00	25	284T	19.2	091488		2400	1.44	10	215T	19.0	091519
3450	1.00	20	256T	19.2	091489		2400	1.44	7.5	213-215T	19.0	091520
3450	1.00	15	254T	19.2	091489							
							2300	1.50	15	254T	19.9	091521
3300	1.05	30	286T	18.8	091490		2300	1.50	10	215T	19.9	091522
3300	1.05	25	284T	18.8	091491		2300	1.50	7.5	213-215T	19.9	091522
3300	1.05	20	256T	18.8	091492		2300	1.50	5	213T	19.9	091523
3300	1.05	15	254T	18.8	091493		2300	1.50	5	184T	19.9	091524
3200	1.08	30	286T	18.2	091494		2200	1.57	15	254T	19.6	091525
3200	1.08	25	284T	18.2	091494		2200	1.57	10	215T	19.6	091526
3200	1.08	20	256T	18.2	091495		2200	1.57	7.5	213-215T	19.6	091527
3200	1.08	15	254T	18.2	091495		2200	1.57	5	213T	19.6	091527
							2200	1.57	5	184T	19.6	091528
3100	1.11	30	286T	19.0	091496		2100	1.64	15	254T	18.9	091529
3100	1.11	25	284T	19.0	091496		2100	1.64	10	215T	18.9	091530
3100	1.11	20	256T	19.0	091497		2100	1.64	7.5	213-215T	18.9	091530
3100	1.11	15	254T	19.0	091498		2100	1.64	5	213T	18.9	091531
							2100	1.64	5	184T	18.9	091532
3000	1.15	25	284T	19.5	091499							
3000	1.15	20	256T	19.5	091500		2000	1.73	7.5	213-215T	19.4	091533
3000	1.15	15	254T	19.5	091500		2000	1.73	5	213T	19.4	091534
3000	1.15	10	215T	19.5	091501		2000	1.73	5	184T	19.4	091535
							2000	1.73	3	182-184T	19.4	091536
2900	1.19	25	284T	19.9	091502							
2900	1.19	20	256T	19.9	091503		1900	1.82	7.5	213-215T	19.2	091537
2900	1.19	15	254T	19.9	091504		1900	1.82	5	213T	19.2	091538
2900	1.19	10	215T	19.9	091505		1900	1.82	5	184T	19.2	091539
							1900	1.82	3	182-184T	19.2	091540
2800	1.23	25	284T	18.7	091506							
2800	1.23	20	256T	18.7	091507		1750	1.97	5	213T	18.7	091541
2800	1.23	15	254T	18.7	091507		1750	1.97	5	184T	18.7	091542
2800	1.23	10	215T	18.7	091508		1750	1.97	3	182-184T	18.7	091542
2700	1.28	25	284T	19.6	091509							
2700	1.28	20	256T	19.6	091510							
2700	1.28	15	254T	19.6	091511							
2700	1.28	10	215T	19.6	091512							
2700	1.28	7.5	213-215T	19.6	091513							
2600	1.33	15	254T	19.3	091514							
2600	1.33	10	215T	19.3	091515							
2600	1.33	7.5	213-215T	19.3	091515							
2500	1.38	15	254T	19.7	091516							
2500	1.38	10	215T	19.7	091517							
2500	1.38	7.5	213-215T	19.7	091517							

# Series B40

Pump End  
4" Flange



## Self-Priming Universal/Electric Driven

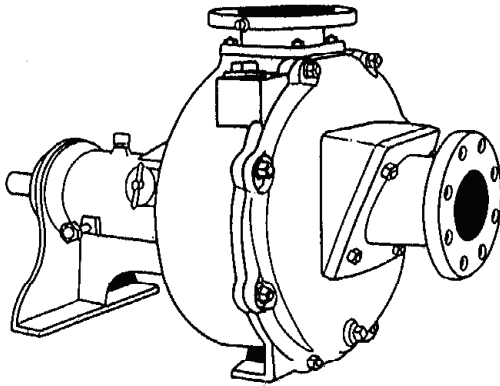

### Specifications:

**SUCTION/DISCHARGE**..... 4" (102mm) x 4" (102mm) 125lb. Flange  
**LIQUID TEMPERATURE** .....160°F (71°C) Continuous  
**VOLUTE/WEARPLATE** .....Cast Iron ASTM A-48, Class 30,  
 Replaceable, External Clearance Adjustment  
**CASE**.....Cast Iron ASTM A-48, Class 30  
**END COVER** .....Cast Iron ASTM A-48, Class 30  
**SEAL PLATE** .....Alloy Steel, Replaceable  
**PEDESTAL**.....Cast Iron ASTM A-48, Class 30  
**IMPELLER: Design** .....Semi-Open Type, Passes 1" Solids  
**Material** .....Cast Iron ASTM A-48, Class 30  
 Dynamically Balanced, ISO G6.3  
**IMPELLER SHAFT** .....Steel  
**SQUARE RINGS** .....Buna-N  
**HARDWARE** .....Corrosion Resistant Steel  
**PAINT** .....Air Dry Enamel  
**SEAL Design** .....Single Mechanical  
**Lubrication** .....Grease, with Self-Feeding Lubricator  
**Material** .....Rotating Faces - Carbon  
 Stationary Faces - Ceramic  
 Elastomer - Buna-N  
 Hardware - 300 Series Stainless

**BEARING - PUMP END**  
**Design**.....Double Row, Ball  
**Lubrication** .....Oil  
**Load**.....Radial & Thrust

**BEARING - DRIVE END**  
**Design**.....Single Row, Ball  
**Lubrication** .....Oil  
**Load**.....Radial & Thrust

**CHECK VALVE:**  
**Material** .....Elbow - Cast Iron ASTM A-48, Class 30  
 Valve Flap-Neoprene  
 Weight-Cast Iron ASTM A-48, Class 30

**OPTIONAL EQUIPMENT**.....Seal Material, Case Heater, Stainless  
 Hardware; High Temperature Control; Flex Coupled Assy., with Base &  
 OSHA Guard; Right Hand V-Belt Drive Assy., Left Hand V-Belt Drive Assy.,  
 and In-Line Vertical V-Belt Drive Assy., with Base, Motor Adjusting Base &  
 OSHA Guard.

**Series: B40-10X  
B40-9H  
B40-9D  
B40-8F**

### DESCRIPTION:

SELF-PRIMING CENTRIFUGAL PUMPS  
DESIGNED FOR MARINE, MUNICIPAL AND  
INDUSTRIAL APPLICATIONS

SECTION 4E  
PAGE 56  
DATE 10/07



**PUMPS & SYSTEMS**

A Crane Co. Company

USA: (937) 778-8947 • Canada: (905) 457-6223 • International: (937) 615-3598

## Self-Priming Universal/Electric Driven

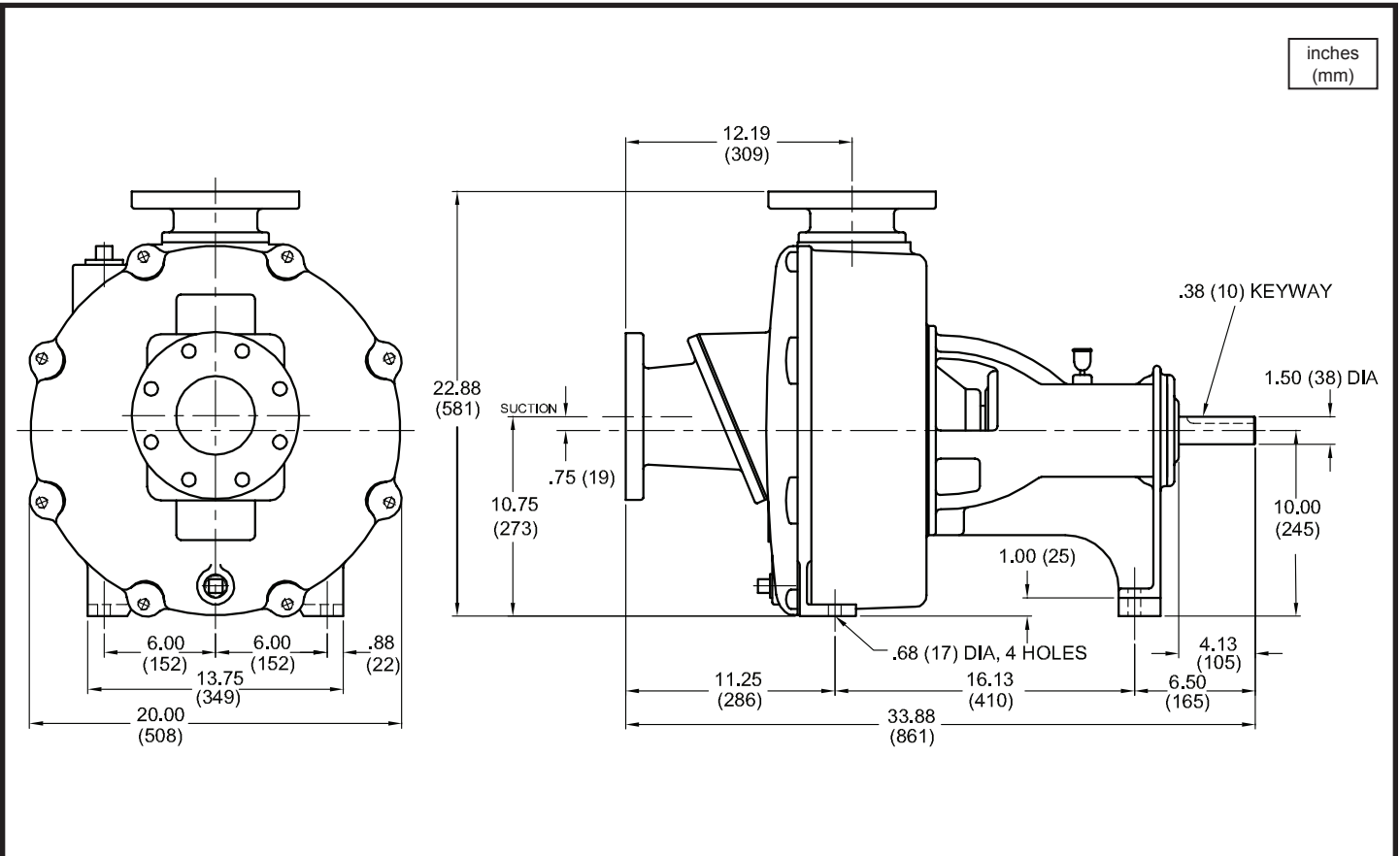

MODEL NO	PART NO	WEIGHT NET LBS (kg)	
B40-10X	4COYD-0010X-001	340 (154)	
B40-9H	4COYD-0009H-001	340 (154)	
B40-9D	4COYD-0009D-001	340 (154)	
B40-8F	4COYD-0008F-001	340 (154)	

**IMPORTANT !**

- DO NOT USE FOR PUMPING FLUIDS WITH A FLASH POINT OF LESS THAN 100°F.
- MAKE CERTAIN THAT PUMP AND/OR MOTOR ASSEMBLY AND CONTROLS HAVE THE APPROPRIATE RATINGS FOR THE GIVEN APPLICATION AREA CLASSIFICATION. (ie DIVISION I, AGENCY LISTING ETC.)

# Series B40-10X

Performance Curve  
Pump End



## Self-Priming Universal/Electric Driven

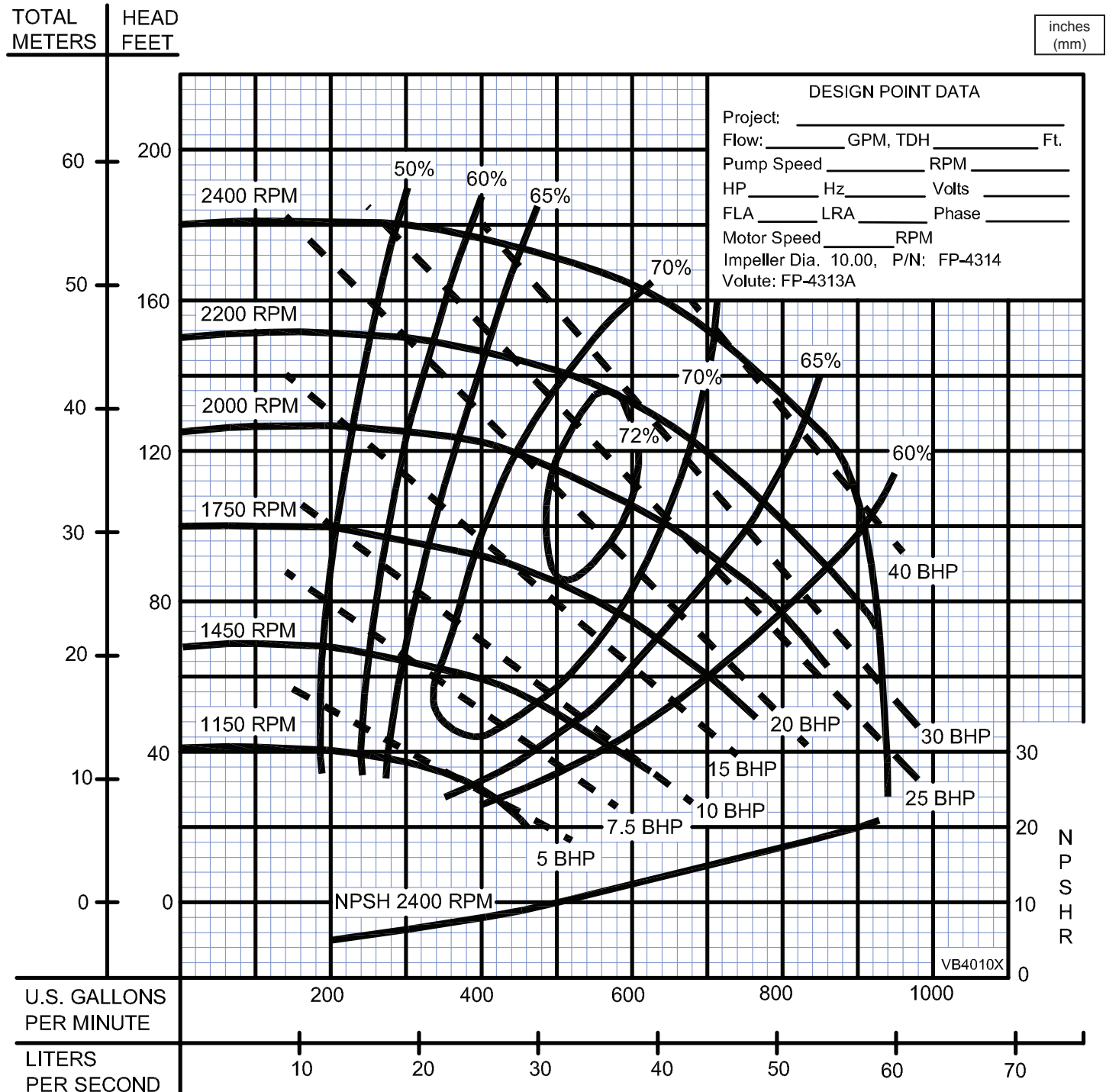

MAXIMUM DRY PRIMING LIFT	
<b>PUMP SPEED</b>	<b>10 Min</b>
1150 RPM	10 Ft.
1450 RPM	15 Ft.
1750 RPM	25 Ft.
2000 RPM	25 Ft.
2200 RPM	25 Ft.
2400 RPM	25 Ft.

When pump is operating, the **SUCTION LIFT** is limited by the available **NPSH** which is the corrected atmospheric pressure minus the dynamic suction lift, vapor pressure loss and 2 foot safety factor. This **net available NPSH** must exceed the **required NPSH** of the pump or a reduction of capacity, loss of efficiency, noise, vibration and cavitation will result. Calculate the dynamic suction lift from the **low** liquid level to the centerline of the impeller. When pump is priming, it is limited by the dry **PRIMING LIFT** which is the vertical distance from the **high** liquid level to the centerline of the impeller.

Testing is performed with water, specific gravity 1.0 @ 68° F @ (20°C), other fluids may vary performance

SECTION 4E  
PAGE 58  
DATE 5/05



## PUMPS & SYSTEMS

## Self-Priming Universal/Electric Driven

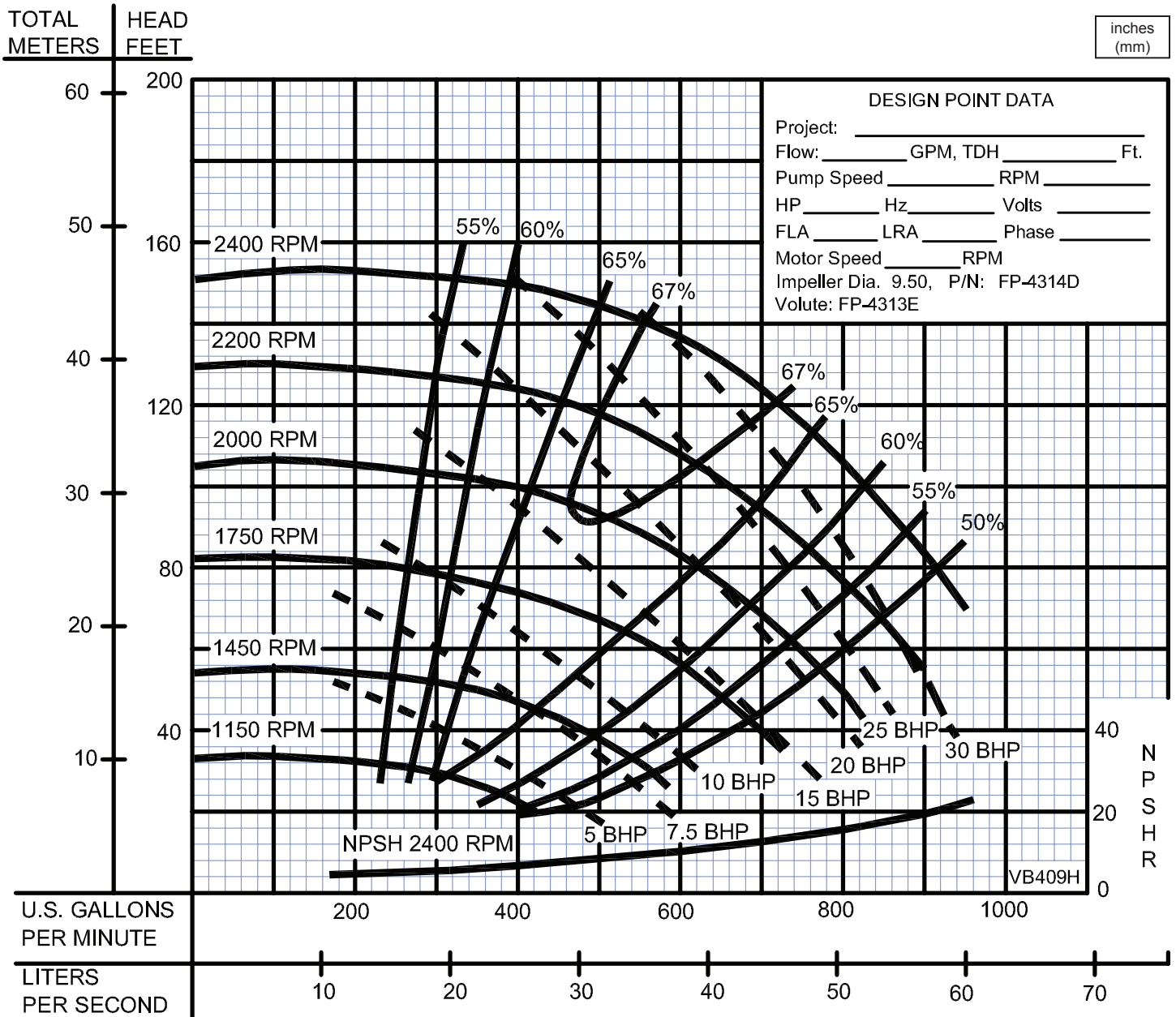

MAXIMUM DRY PRIMING LIFT	
<b>PUMP SPEED</b>	<b>10 Min</b>
1150 RPM	10 Ft.
1450 RPM	15 Ft.
1750 RPM	20 Ft.
2000 RPM	25 Ft.
2200 RPM	25 Ft.
2400 RPM	25 Ft.

When pump is operating, the **SUCTION LIFT** is limited by the available **NPSH** which is the corrected atmospheric pressure minus the dynamic suction lift, vapor pressure loss and 2 foot safety factor. This **net available NPSH** must exceed the **required NPSH** of the pump or a reduction of capacity, loss of efficiency, noise, vibration and cavitation will result. Calculate the dynamic suction lift from the **low** liquid level to the centerline of the impeller. When pump is priming, it is limited by the dry **PRIMING LIFT** which is the vertical distance from the **high** liquid level to the centerline of the impeller.

Testing is performed with water, specific gravity 1.0 @ 68° F @ (20°C), other fluids may vary performance



# Series B40-9D

Performance Curve  
Pump End



## Self-Priming Universal/Electric Driven

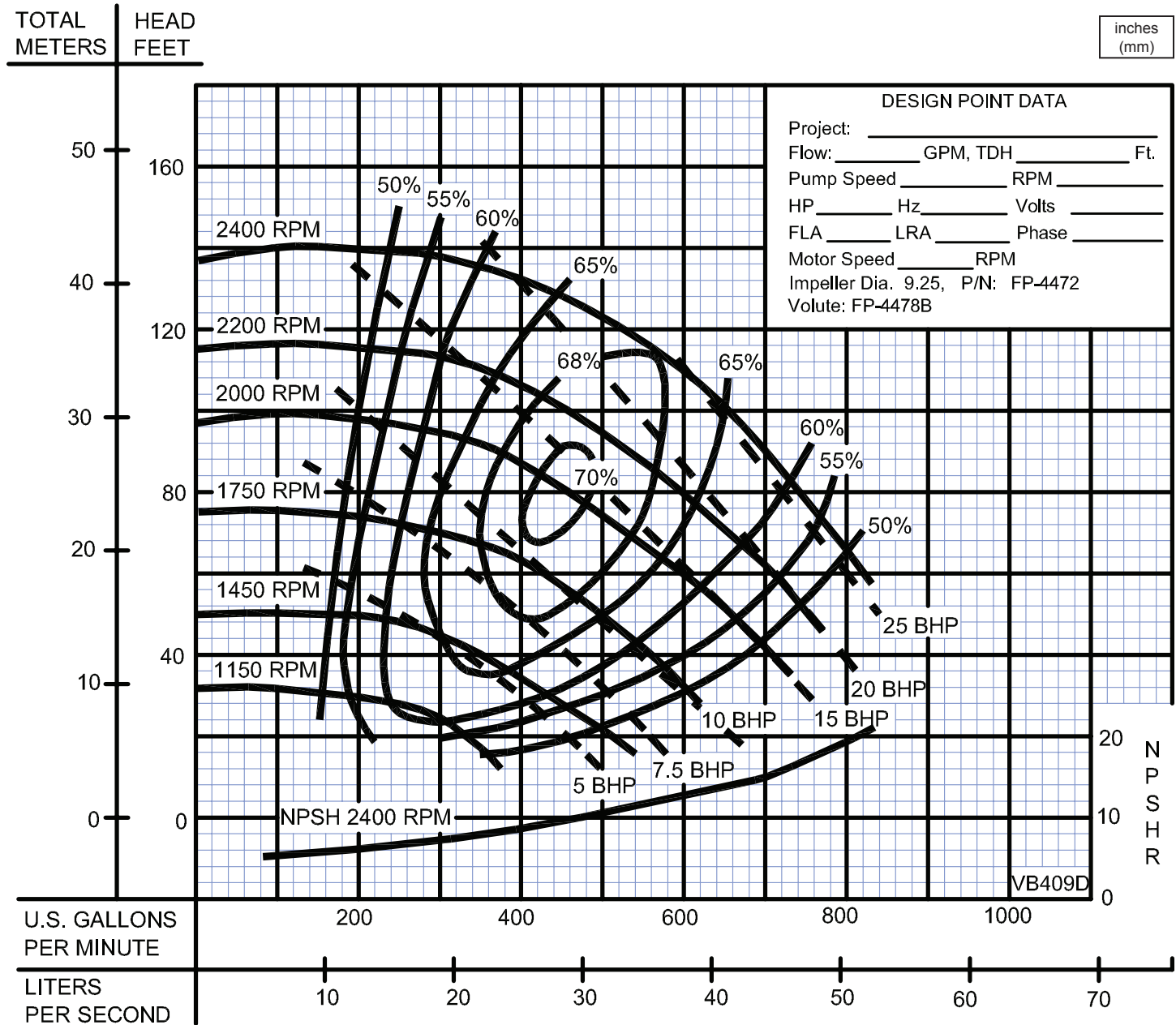

MAXIMUM DRY PRIMING LIFT	
<b>PUMP SPEED</b>	<b>10 Min</b>
1150 RPM	15 Ft.
1450 RPM	25 Ft.
1750 RPM	25 Ft.
2000 RPM	25 Ft.
2200 RPM	25 Ft.
2400 RPM	25 Ft.

When pump is operating, the **SUCTION LIFT** is limited by the available **NPSH** which is the corrected atmospheric pressure minus the dynamic suction lift, vapor pressure loss and 2 foot safety factor. This **net available NPSH** must exceed the **required NPSH** of the pump or a reduction of capacity, loss of efficiency, noise, vibration and cavitation will result. Calculate the dynamic suction lift from the **low** liquid level to the centerline of the impeller. When pump is priming, it is limited by the dry **PRIMING LIFT** which is the vertical distance from the **high** liquid level to the centerline of the impeller.

Testing is performed with water, specific gravity 1.0 @ 68° F @ (20°C), other fluids may vary performance

SECTION 4E  
PAGE 60  
DATE 5/05



## PUMPS & SYSTEMS

A Crane Co. Company

USA: (937) 778-8947 • Canada: (905) 457-6223 • International: (937) 615-3598



## Self-Priming Universal/Electric Driven

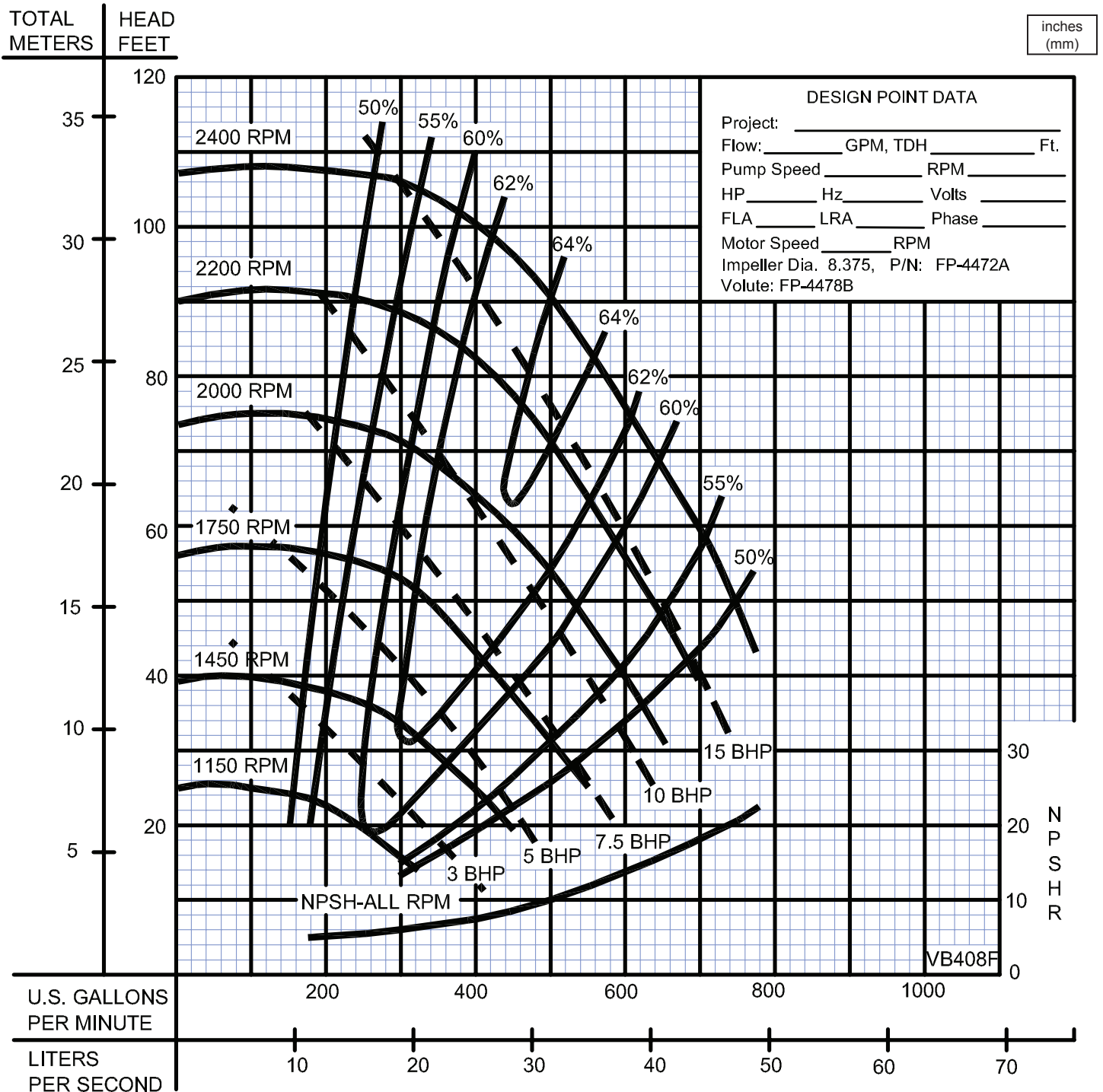

MAXIMUM DRY PRIMING LIFT	
<b>PUMP SPEED</b>	<b>10 Min</b>
1150 RPM	10 Ft.
1450 RPM	15 Ft.
1750 RPM	25 Ft.
2000 RPM	25 Ft.
2200 RPM	25 Ft.
2400 RPM	25 Ft.

When pump is operating, the **SUCTION LIFT** is limited by the available **NPSH** which is the corrected atmospheric pressure minus the dynamic suction lift, vapor pressure loss and 2 foot safety factor. This **net available NPSH** must exceed the **required NPSH** of the pump or a reduction of capacity, loss of efficiency, noise, vibration and cavitation will result. Calculate the dynamic suction lift from the **low** liquid level to the centerline of the impeller. When pump is priming, it is limited by the dry **PRIMING LIFT** which is the vertical distance from the **high** liquid level to the centerline of the impeller.

Testing is performed with water, specific gravity 1.0 @ 68° F @ (20°C), other fluids may vary performance

# Series B40

Horizontal V-Belt Base, Motor Speed: **1750 RPM**  
 V-Belt Drive, Sheaves & Bushings, Pump Shaft: **1.50 Dia.**



## Self-Priming Universal/Electric Driven

Driven Speed	Speed Ratio	Motor HP	Frame Size	Center Distance	Drive P/N		Driven Speed	Speed Ratio	Motor HP	Frame Size	Center Distance	Drive P/N
2400	1.37	75	365T	22.2	091771		1750	1.00	30	286T	23.2	091810
2400	1.37	60	364T	22.2	091771		1750	1.00	25	284T	23.2	091810
2400	1.37	50	326T	22.2	091772		1750	1.00	20	256T	23.2	091811
2400	1.37	40	324T	22.1	091773		1750	1.00	15	254T	23.2	091812
2400	1.37	30	286T	22.1	091774		1750	1.00	10	215T	23.2	091813
2400	1.37	25	284T	22.1	091775		1750	1.00	7.5	213-215T	23.2	091813
							1750	1.00	5.0	213T	23.2	091813
							1750	1.00	5.0	184T	23.2	091814
2300	1.31	60	364T	22.6	091776		1750	1.00	5.0	184T	23.2	091814
2300	1.31	50	326T	22.6	091777							
2300	1.31	40	324T	21.9	091778		1600	1.09	30	286T	23.7	091815
2300	1.31	30	286T	21.9	091779		1600	1.09	25	284T	23.7	091816
2300	1.31	25	284T	21.9	091780		1600	1.09	20	256T	23.7	091817
2300	1.31	20	256T	21.9	091781		1600	1.09	15	254T	23.7	091817
2300	1.31	15	254T	21.9	091782		1600	1.09	10	215T	23.7	091818
							1600	1.09	7.5	213-215T	23.7	091818
2200	1.25	60	364T	22.8	091783		1600	1.09	5.0	213T	23.7	091819
2200	1.25	50	326T	22.8	091784		1600	1.09	5.0	184T	23.7	091820
2200	1.25	40	324T	23.1	091785							
2200	1.25	30	286T	23.1	091786		1450	1.20	15	254T	22.9	091821
2200	1.25	25	284T	23.1	091787		1450	1.20	10	215T	22.9	091822
2200	1.25	20	256T	23.1	091788		1450	1.20	7.5	213-215T	22.9	091822
2200	1.25	15	254T	23.1	091789		1450	1.20	5.0	213T	22.9	091823
2200	1.25	10	215T	23.1	091790		1450	1.20	5.0	184T	22.9	091824
2100	1.20	50	326T	23.2	091791		1300	1.35	15	254T	23.2	091825
2100	1.20	40	324T	23.2	091792		1300	1.35	10	215T	23.2	091826
2100	1.20	30	286T	22.9	091793		1300	1.35	7.5	213-215T	23.2	091827
2100	1.20	25	284T	22.9	091794		1300	1.35	5.0	213T	23.2	091827
2100	1.20	20	256T	22.9	091795		1300	1.35	5.0	184T	23.2	091828
2100	1.20	15	254T	22.9	091796		1300	1.35	3.0	182-184T	23.2	091829
2100	1.20	10	215T	22.9	091797							
							1150	1.52	7.5	213-215T	21.8	091830
2000	1.14	50	326T	23.4	091798		1150	1.52	5.0	213T	21.8	091831
2000	1.14	40	324T	23.4	091799		1150	1.52	5.0	184T	21.8	091832
2000	1.14	30	286T	23.4	091800		1150	1.52	3.0	182-184T	21.8	091833
2000	1.14	25	284T	23.4	091801							
2000	1.14	20	256T	23.4	091802							
2000	1.14	15	254T	23.4	091803							
2000	1.14	10	215T	23.4	091804							
2000	1.14	7.5	213-215T	23.4	091804							
1900	1.09	40	324T	23.7	091805							
1900	1.09	30	286T	23.7	091806							
1900	1.09	25	284T	23.7	091807							
1900	1.09	20	256T	23.7	091808							
1900	1.09	15	254T	23.7	091808							
1900	1.09	10	215T	23.7	091809							
1900	1.09	7.5	213-215T	23.7	091809							

**Self-Priming Universal/Electric Driven**

**Specifications:**

**SUCTION/DISCHARGE**..... 6" (152mm) x 6" (152mm) 125lb. Flange  
**LIQUID TEMPERATURE** .....160°F (71°C) Continuous  
**VOLUTE/WEARPLATE** .....Cast Iron ASTM A-48, Class 30,  
 Replaceable, External Clearance Adjustment  
**CASE**.....Cast Iron ASTM A-48, Class 30  
**END COVER** .....Cast Iron ASTM A-48, Class 30  
**SEAL PLATE** .....Alloy Steel, Replaceable  
**PEDESTAL**.....Cast Iron ASTM A-48, Class 30  
**IMPELLER: Design** .....Semi-Open Type, Passes 1-1/2" Solids  
**Material** .....Cast Iron ASTM A-48, Class 30  
 Dynamically Balanced, ISO G6.3  
**IMPELLER SHAFT** .....Steel  
**SQUARE RINGS** .....Buna-N  
**HARDWARE** .....Corrosion Resistant Steel  
**PAINT** .....Air Dry Enamel  
**SEAL Design** .....Single Mechanical  
**Lubrication** .....Grease, with Self-Feeding Lubricator  
**Material** .....Rotating Faces - Carbon  
 Stationary Faces - Ceramic  
 Elastomer - Buna-N  
 Hardware - 300 Series Stainless

**BEARING - PUMP END**  
**Design**.....Single Row, Ball  
**Lubrication** .....Oil  
**Load**.....Radial & Thrust

**BEARING - DRIVE END**  
**Design**.....Single Row, Ball  
**Lubrication** .....Oil  
**Load**.....Radial & Thrust

**CHECK VALVE:**  
**Material** .....Elbow - Cast Iron ASTM A-48, Class 30  
 Valve Flap - Neoprene  
 Weight - Cast Iron ASTM A-48, Class 30

**OPTIONAL EQUIPMENT**.....Seal Material, Case Heater, Stainless  
 Hardware; High Temperature Control; Flex Coupled Assy., with Base &  
 OSHA Guard; Right Hand V-Belt Drive Assy., Left Hand V-Belt Drive Assy.,  
 and In-Line Vertical V-Belt Drive Assy., with Base, Motor Adjusting Base &  
 OSHA Guard.

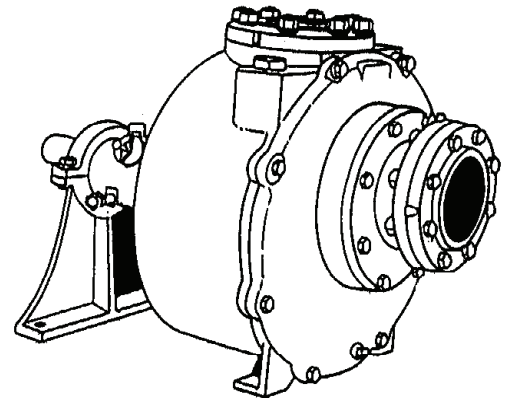

**Series: B60-12X  
 B60-11H  
 B60-11X  
 B60-10L**

**DESCRIPTION:**

SELF-PRIMING CENTRIFUGAL PUMPS  
 DESIGNED FOR MARINE, MUNICIPAL AND  
 INDUSTRIAL APPLICATIONS

# Series B60

Pump End  
6" Flange



## Self-Priming Universal/Electric Driven

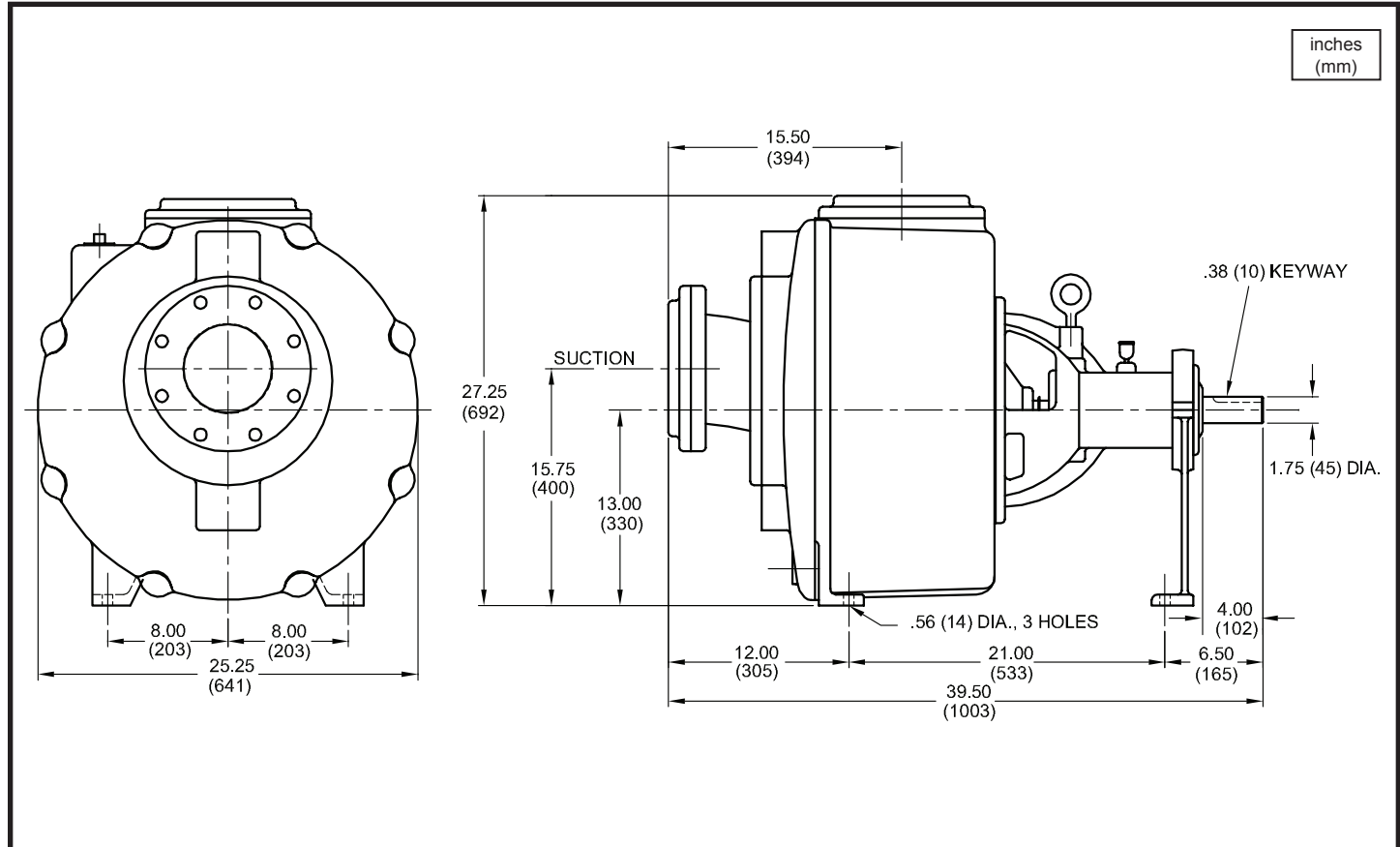

MODEL NO	PART NO	WEIGHT NET LBS (kg)	
B60-12X	6COZD-0012X-001	585 (265)	
B60-11H	6COZD-0011H-001	585 (265)	
B60-11X	6COZD-0011X-001	585 (265)	
B60-10L	6COZD-0010L-001	585 (265)	

### IMPORTANT !

- DO NOT USE FOR PUMPING FLUIDS WITH A FLASH POINT OF LESS THAN 100°F.
- MAKE CERTAIN THAT PUMP AND/OR MOTOR ASSEMBLY AND CONTROLS HAVE THE APPROPRIATE RATINGS FOR THE GIVEN APPLICATION AREA CLASSIFICATION. (ie DIVISION I, AGENCY LISTING ETC.)

SECTION 4E  
PAGE 64  
DATE 5/05

**CRANE**<sup>®</sup>

A Crane Co. Company

**PUMPS & SYSTEMS**

USA: (937) 778-8947 • Canada: (905) 457-6223 • International: (937) 615-3598

## Self-Priming Universal/Electric Driven

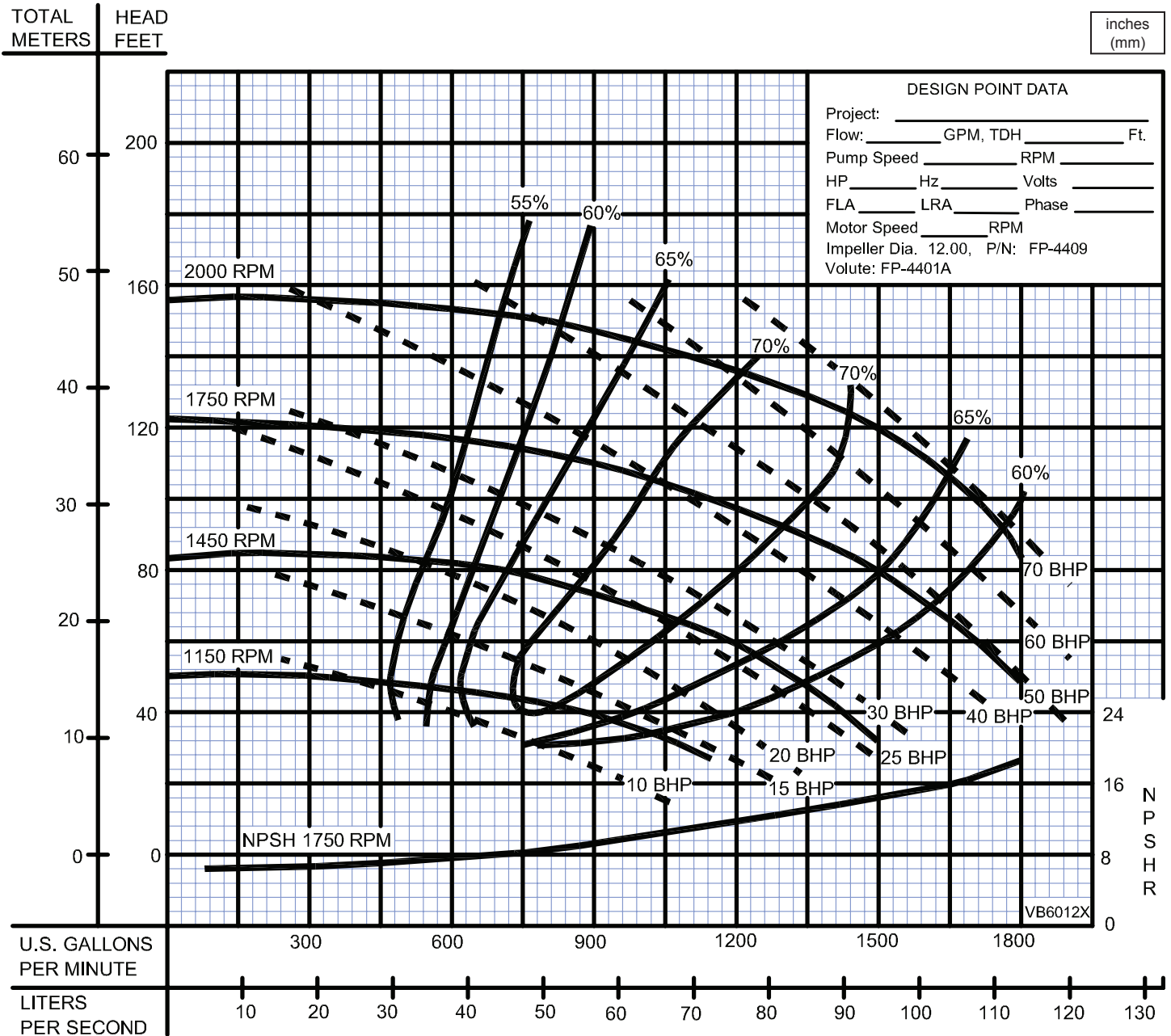

MAXIMUM DRY PRIMING LIFT	
<b>PUMP SPEED</b>	<b>10 Min</b>
1150 RPM	20 Ft.
1450 RPM	25 Ft.
1750 RPM	25 Ft.
2000 RPM	25 Ft.
2250 RPM	25 Ft.

When pump is operating, the **SUCTION LIFT** is limited by the available **NPSH** which is the corrected atmospheric pressure minus the dynamic suction lift, vapor pressure loss and 2 foot safety factor. This **net available NPSH** must exceed the **required NPSH** of the pump or a reduction of capacity, loss of efficiency, noise, vibration and cavitation will result. Calculate the dynamic suction lift from the **low** liquid level to the centerline of the impeller. When pump is priming, it is limited by the dry **PRIMING LIFT** which is the vertical distance from the **high** liquid level to the centerline of the impeller.

Testing is performed with water, specific gravity 1.0 @ 68° F @ (20°C), other fluids may vary performance

# Series B60-11H

Performance Curve  
Pump End



## Self-Priming Universal/Electric Driven

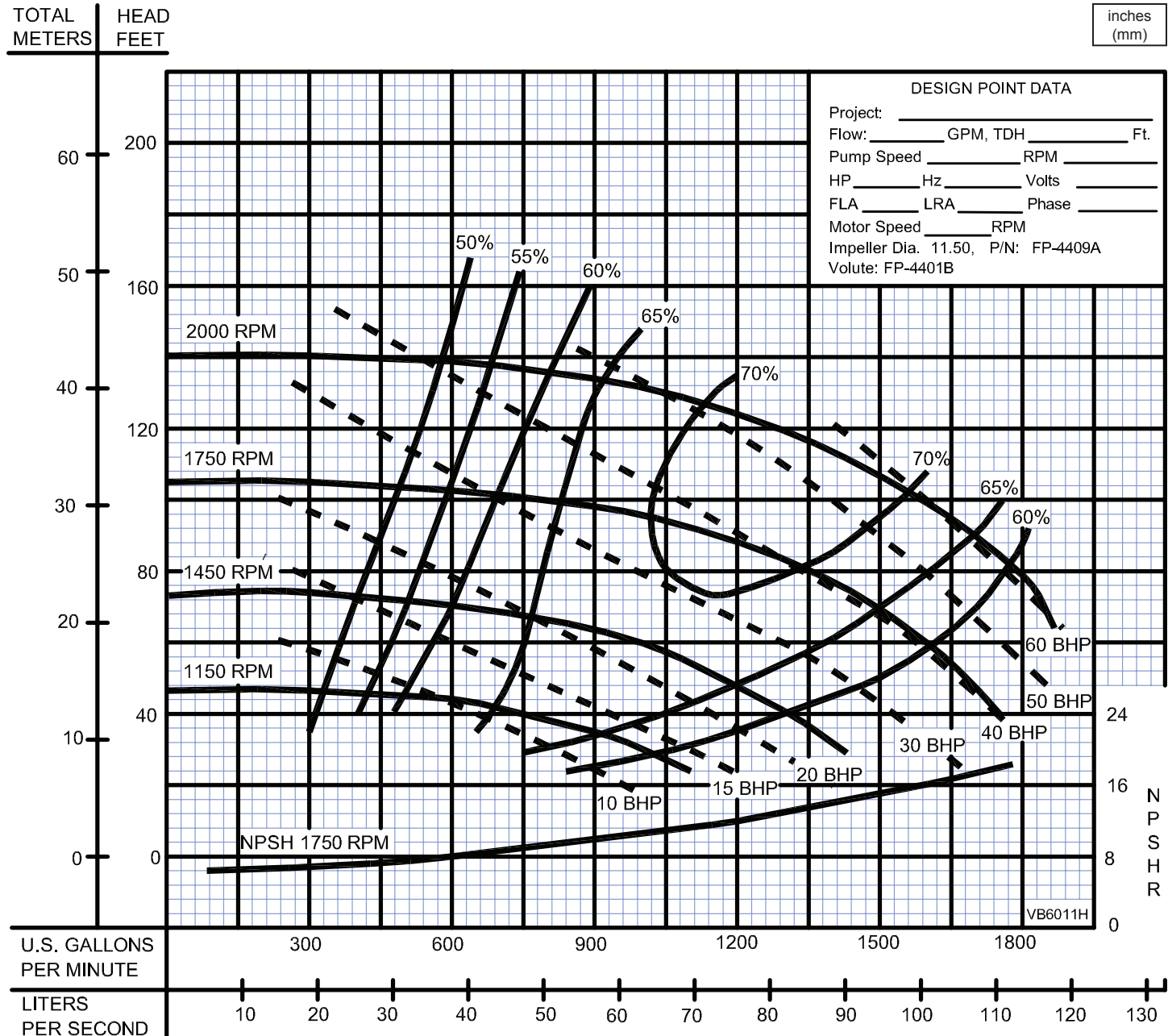

MAXIMUM DRY PRIMING LIFT	
<b>PUMP SPEED</b>	<b>10 Min</b>
1150 RPM	20 Ft.
1450 RPM	25 Ft.
1750 RPM	25 Ft.
2000 RPM	25 Ft.
2250 RPM	25 Ft.

When pump is operating, the **SUCTION LIFT** is limited by the available **NPSH** which is the corrected atmospheric pressure minus the dynamic suction lift, vapor pressure loss and 2 foot safety factor. This **net available NPSH** must exceed the **required NPSH** of the pump or a reduction of capacity, loss of efficiency, noise, vibration and cavitation will result. Calculate the dynamic suction lift from the **low** liquid level to the centerline of the impeller. When pump is priming, it is limited by the dry **PRIMING LIFT** which is the vertical distance from the **high** liquid level to the centerline of the impeller.

Testing is performed with water, specific gravity 1.0 @ 68° F @ (20°C), other fluids may vary performance

SECTION 4E  
PAGE 66  
DATE 5/05



PUMPS & SYSTEMS

A Crane Co. Company

USA: (937) 778-8947 • Canada: (905) 457-6223 • International: (937) 615-3598



## Self-Priming Universal/Electric Driven

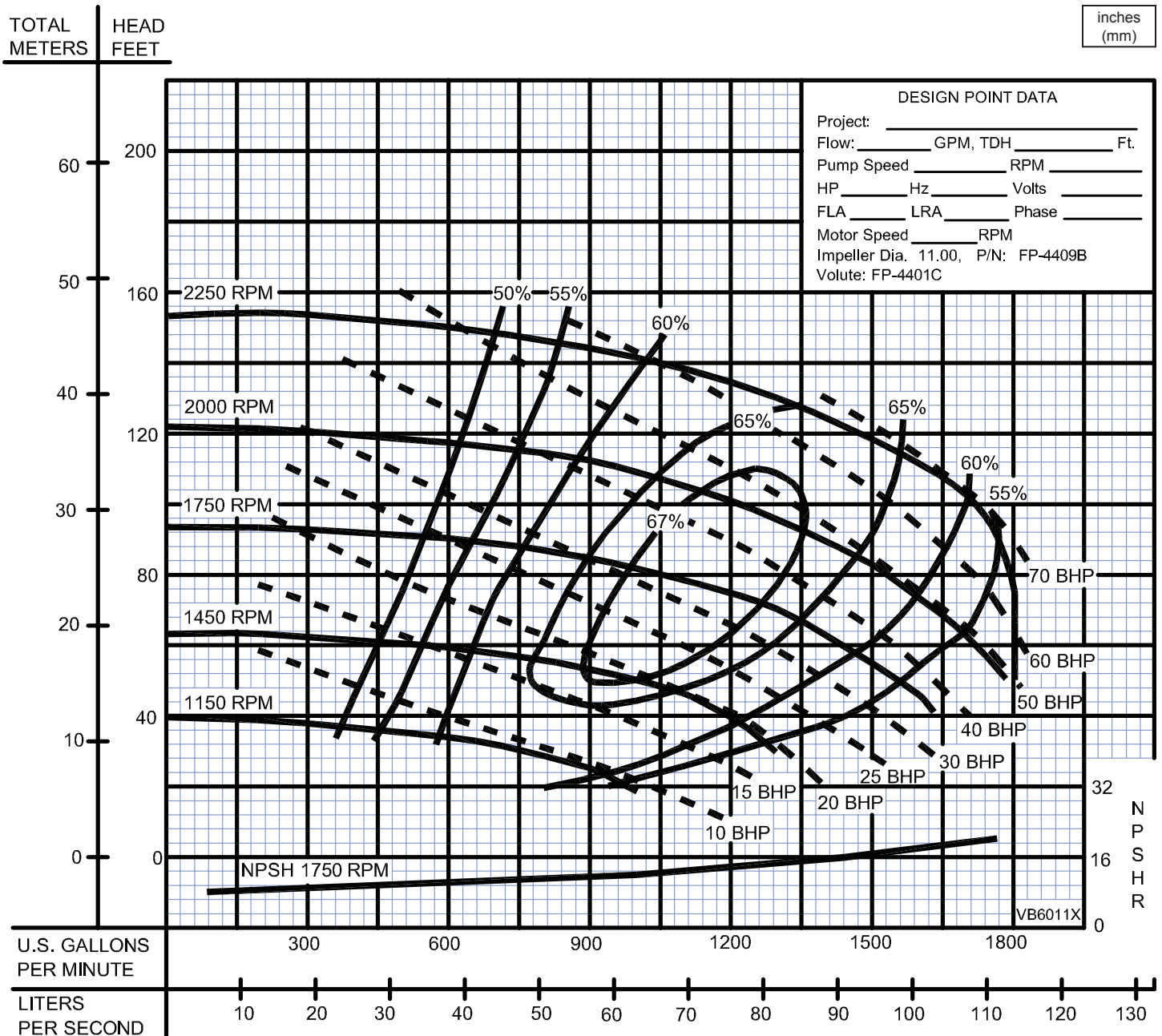

MAXIMUM DRY PRIMING LIFT	
<b>PUMP SPEED</b>	<b>10 Min</b>
1150 RPM	20 Ft.
1450 RPM	25 Ft.
1750 RPM	25 Ft.
2000 RPM	25 Ft.
2250 RPM	25 Ft.

When pump is operating, the **SUCTION LIFT** is limited by the available **NPSH** which is the corrected atmospheric pressure minus the dynamic suction lift, vapor pressure loss and 2 foot safety factor. This **net available NPSH** must exceed the **required NPSH** of the pump or a reduction of capacity, loss of efficiency, noise, vibration and cavitation will result. Calculate the dynamic suction lift from the **low** liquid level to the centerline of the impeller. When pump is priming, it is limited by the dry **PRIMING LIFT** which is the vertical distance from the **high** liquid level to the centerline of the impeller.

Testing is performed with water, specific gravity 1.0 @ 68° F @ (20°C), other fluids may vary performance

# Series B60-10L

Performance Curve  
Pump End



## Self-Priming Universal/Electric Driven

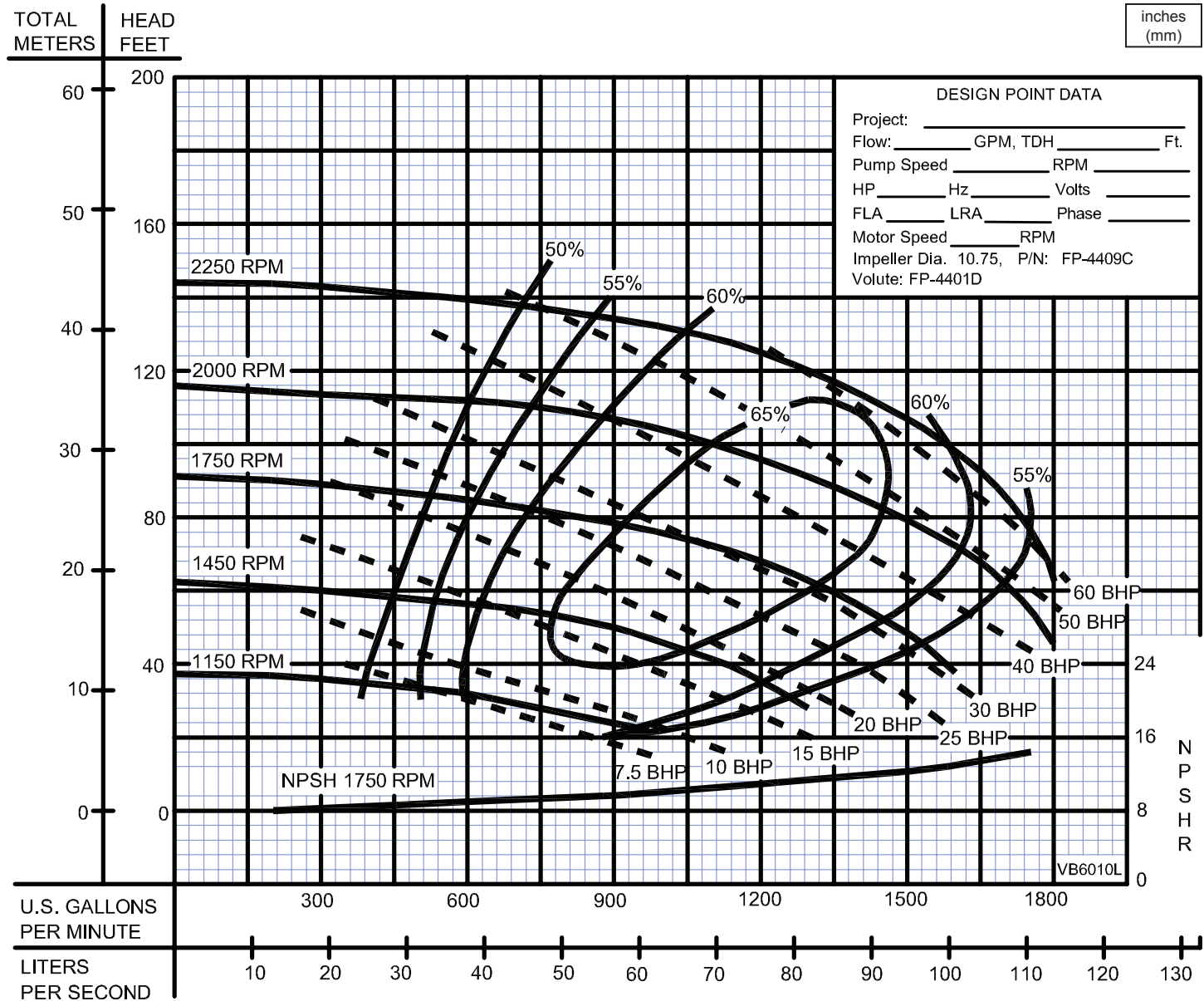

MAXIMUM DRY PRIMING LIFT	
<b>PUMP SPEED</b>	<b>10 Min</b>
1150 RPM	20 Ft.
1450 RPM	25 Ft.
1750 RPM	25 Ft.
2000 RPM	25 Ft.
2250 RPM	25 Ft.

When pump is operating, the **SUCTION LIFT** is limited by the available **NPSH** which is the corrected atmospheric pressure minus the dynamic suction lift, vapor pressure loss and 2 foot safety factor. This **net available NPSH** must exceed the **required NPSH** of the pump or a reduction of capacity, loss of efficiency, noise, vibration and cavitation will result. Calculate the dynamic suction lift from the **low** liquid level to the centerline of the impeller. When pump is priming, it is limited by the dry **PRIMING LIFT** which is the vertical distance from the **high** liquid level to the centerline of the impeller.

Testing is performed with water, specific gravity 1.0 @ 68° F @ (20°C), other fluids may vary performance

SECTION 4E  
PAGE 68  
DATE 5/05



PUMPS & SYSTEMS

A Crane Co. Company

USA: (937) 778-8947 • Canada: (905) 457-6223 • International: (937) 615-3598





# Series B60

Horizontal V-Belt Base, Motor Speed: 1750 RPM  
V-Belt Drive, Sheaves & Bushings, Pump Shaft: 1.75 Dia.

## Self-Priming Universal/Electric Driven

Driven Speed	Speed Ratio	Motor HP	Frame Size	Center Distance	Drive P/N		Driven Speed	Speed Ratio	Motor HP	Frame Size	Center Distance	Drive P/N
2250	1.29	150	405T	30.4	091834		1450	1.20	50	326T	30.2	091871
2250	1.29	125	405T	30.4	091835		1450	1.20	40	324T	30.2	091872
2250	1.29	100	404-405T	30.4	091835		1450	1.20	30	286T	31.4	091873
2250	1.29	75	365T	30.4	091836		1450	1.20	25	284T	31.4	091874
2250	1.29	60	364T	30.6	091837		1450	1.20	20	256T	31.4	091875
2250	1.29	50	326T	30.6	091838		1450	1.20	15	254T	31.4	091876
2100	1.20	125	405T	30.6	091839		1300	1.35	30	286T	31.5	091877
2100	1.20	100	404-405T	30.6	091840		1300	1.35	25	284T	31.5	091878
2100	1.20	75	365T	30.2	091841		1300	1.35	20	256T	31.5	091879
2100	1.20	60	364T	30.2	091842		1300	1.35	15	254T	31.5	091879
2100	1.20	50	326T	30.2	091843		1300	1.35	10	215T	31.5	091880
2100	1.20	40	324T	30.2	091844		1150	1.52	25	284T	32.0	091881
2000	1.14	125	405T	30.1	091845		1150	1.52	20	256T	32.0	091882
2000	1.14	100	404-405T	30.1	091846		1150	1.52	15	254T	32.0	091883
2000	1.14	75	365T	30.1	091847		1150	1.52	10	215T	32.0	091884
2000	1.14	60	364T	30.6	091848		1150	1.52	7.5	213-215T	32.0	091884
2000	1.14	50	326T	30.6	091849							
2000	1.14	40	324T	30.6	091850							
2000	1.14	30	286T	30.6	091851							
1900	1.09	125	405T	29.6	091852							
1900	1.09	100	404-405T	29.6	091853							
1900	1.09	75	365T	29.6	091854							
1900	1.09	60	364T	25.6	091855							
1900	1.09	50	326T	29.6	091856							
1900	1.09	40	324T	30.2	091857							
1900	1.09	30	286T	30.2	091858							
1750	1.00	75	365T	30.7	091859							
1750	1.00	60	364T	30.7	091860							
1750	1.00	50	326T	30.7	091861							
1750	1.00	40	324T	30.7	091862							
1750	1.00	30	286T	29.2	091863							
1750	1.00	25	284T	29.2	091864							
1600	1.09	60	364T	31.1	091865							
1600	1.09	50	326T	31.1	091866							
1600	1.09	40	324T	30.2	091867							
1600	1.09	30	286T	30.2	091868							
1600	1.09	25	284T	30.2	091869							
1600	1.09	20	256T	30.2	091870							

## Self-Priming Universal/Electric Driven

DRAWING No.	DESCRIPTION
<b>10ICU Pumps:</b>	
100063	(FB) Flex Coupled Drive
082726	(RV) Right Hand V-Belt Drive
<b>15ICU, 20ICU, 25ICU Pumps:</b>	
066355	(FB) Flex Coupled Drive
101356	(RV) Right Hand V-Belt Drive

<b>B12, SB12, BH7, SBH7, B19, SB19, B21 &amp; SB21 Pumps:</b>	
550-01047	(FB) Flex Coupled Drive
550-01045	(RV) Right Hand V-Belt Drive
550-01044	(LV) Left Hand V-Belt Drive

<b>B30 Pumps:</b>	
550-01023	(FB) Flex Coupled Drive
550-01019	(RV) Right Hand V-Belt Drive
550-01018	(LV) Left Hand V-Belt Drive

<b>B40 Pumps:</b>	
550-01015	(FB) Flex Coupled Drive
550-01057	(RV) Right Hand V-Belt Drive
550-01058	(LV) Left Hand V-Belt Drive
550-00021	(VV) Vertical V-Belt Drive

<b>B60 Pumps:</b>	
550-01008	(FB) Flex Coupled Drive
550-01007	(RV) Right Hand V-Belt Drive
550-01006	(LV) Left Hand V-Belt Drive
550-01067	(VV) Vertical V-Belt Drive

Consult Factory for Specific Design

DIM. CLASSIFICATION  
KEY CHARACTERISTIC \*

FRAME	A	B	C	D	E	F
56	4.88	3.00	—	18.00	24.00	4
143T	3.31	.75	5.25	28.50	30.00	6
145T	3.31	.75	5.25	28.50	30.00	6
182T	3.31	.75	5.25	28.50	30.00	6
184T	3.31	.75	5.25	28.50	30.00	6
213T	3.31	.75	5.25	28.50	30.00	6
215T	3.31	.75	5.25	28.50	30.00	6

REVISIONS		
REV	DESCRIPTION	DATE
A	RELEASE	3-20-97

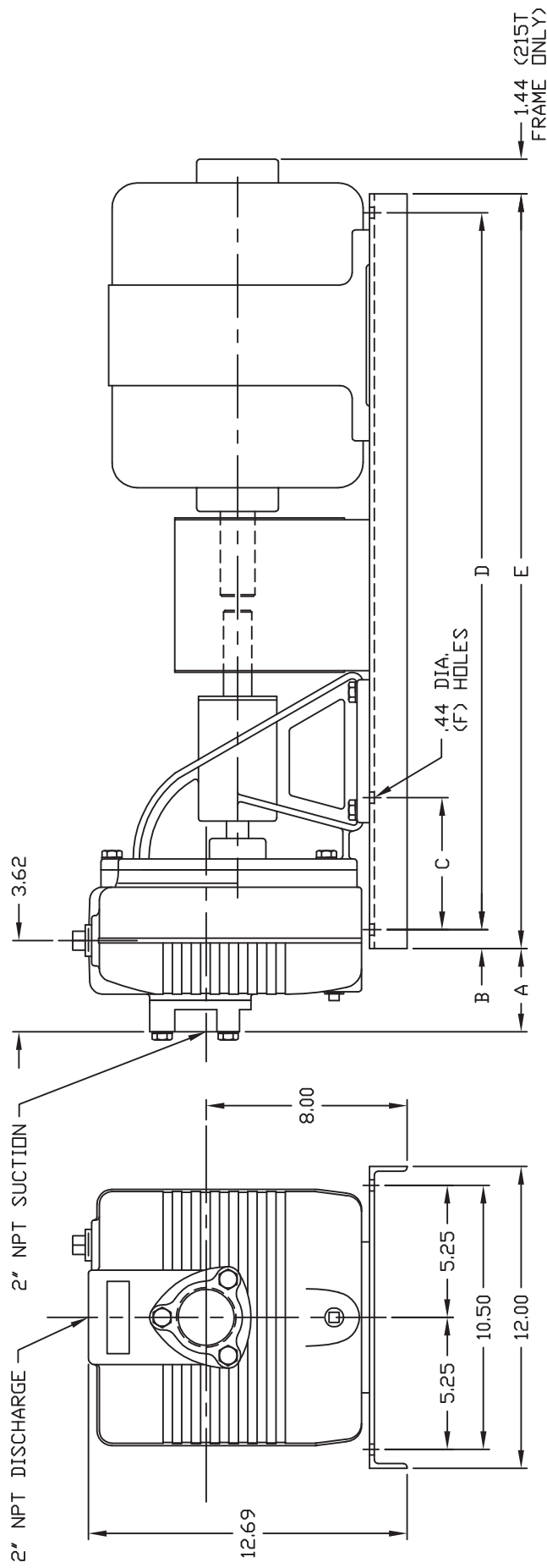

This print is and contains confidential proprietary information owned exclusively by CRANE PUMPS & SYSTEMS INC., and it is furnished on a strictly confidential basis. This restriction includes, but is not limited to, the condition that this print will only be used as a record or to identify or inspect parts or for other information purposes, and will not be used to manufacture or procure the manufacture of the parts shown in this print by any source other than CRANE PUMPS & SYSTEMS INC.

UNLESS OTHERWISE SPECIFIED DIMENSIONS ARE IN INCHES  
TOLERANCES FOR MACH DIM  
2 PL DECIMALS ±.015  
3 PL DECIMALS ±.005  
ANGLES ±1°  
FRACTIONS ±1/16  
TOLERANCES FOR CAST DIM  
FROM 0.00-5.99 ±.030  
FROM 6.00-14.99 ±.045  
FROM 15.00-23.99 ±.060  
FROM 24.00 & UP ±.125  
DO NOT SCALE PRINT

SIGNATURES  
DRAWN **J. CRIM** 3-20-97  
CHECKED **J. CRIM** 3-20-97  
ENGRG  
ISSUED  
MATERIAL  
FINISH

CRANE PUMPS & SYSTEMS  
BURKS PUMPS · BARNES · PROSSER/ENPO · WEINMAN · DEMING  
OUTLINE, 101CU, FLEX-CPLD  
56 THRU 215T MOTOR FRAMES  
SIZE B CAGE NO 96046 DWG NO 100063  
SCALE 1=4 FILE 100063 SHEET 1 OF 1

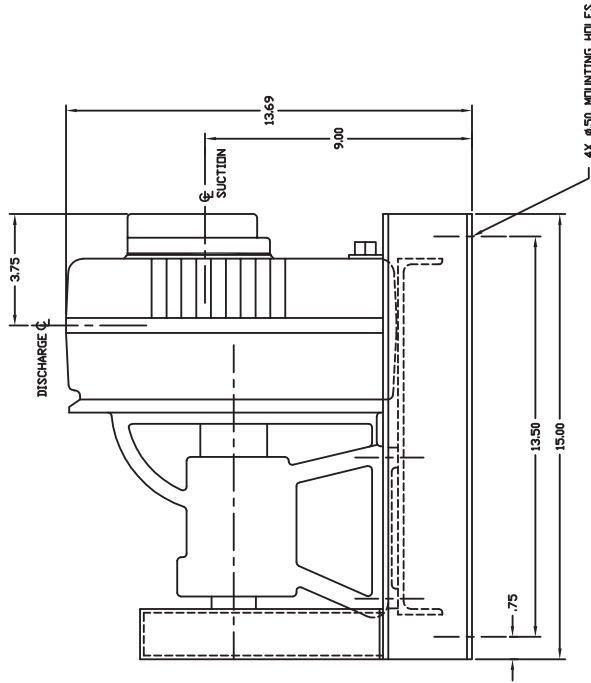
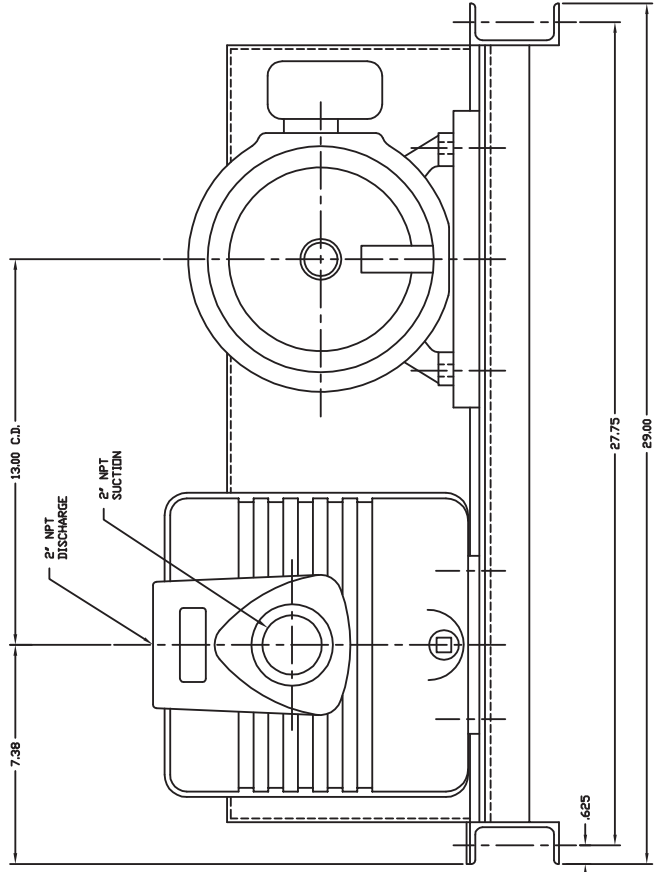

This print is and contains confidential, proprietary information owned exclusively by COME PUMPS & SYSTEMS INC. and it is furnished to the customer under a license. No part of this information may be reproduced, stored, transmitted, or disseminated in any form or by any means without the prior written permission of COME PUMPS & SYSTEMS INC. The licensee agrees to indemnify and hold COME PUMPS & SYSTEMS INC. harmless from and against all claims, damages, losses, and expenses, including reasonable attorneys' fees, that may be incurred by COME PUMPS & SYSTEMS INC. as a result of any use of this information by the licensee, other than as expressly authorized by COME PUMPS & SYSTEMS INC. in writing.

DESIGNER	DATE
MARKET POWER	4-7-92
CHECKED	
DESIGNED	
APPROVED	
ISSUED	
REVISED	

UNLESS OTHERWISE SPECIFIED  
DIMENSIONS ARE IN INCHES  
TOLERANCES FOR HARD SPA  
3.0 DIMENSIONS UNLESS  
SPECIFIED OTHERWISE  
TOLERANCES FOR CAST SPA  
FOR DIMENSIONS FROM 0.00-0.99  
FROM 1.00-4.99 0.010  
FROM 5.00-24.99 0.015  
FROM 25.00-99.99 0.020  
FROM 100-499.99 0.030  
FROM 500-999.99 0.040  
FROM 1000-9999.99 0.050  
FRACTIONS 1/16" MINIMUM  
DO NOT SCALE PRINT

COMPANY	PROJECT
CRANE	PUMPS & SYSTEMS
1451, 185-41 MOTOR FRAMES, RIGHT-HAND	
101CU, V-BELT DRIVEN	
OUTLINE	

SIZE D  
DWG NO 96046  
PAGE NO 082726  
SCALE 1/2 FILE 082726  
SHEET 1 OF 1

FRAME	A	B	C	D	E	F	G
143T	11.19	2.00	—	26.00	41.19	4	—
145T	11.19	2.00	—	26.00	41.19	4	—
182T	8.75	2.00	—	26.00	38.75	4	.81
184T	8.75	2.00	—	26.00	38.75	4	1.81
213T	8.75	1.00	12.00	36.00	46.75	8	—
215T	8.75	1.00	12.00	36.00	46.75	8	—
254T	8.75	1.00	12.00	36.00	46.75	8	—
256T	8.75	1.00	12.00	36.00	46.75	8	1.06

REVISIONS			
REV	DESCRIPTION	DATE	APPROVED
B	00268-97 ADDED 254-6T	3-17-97	JAC
C	00832-99 ADDED 151CU & 201CU	8-4-99	

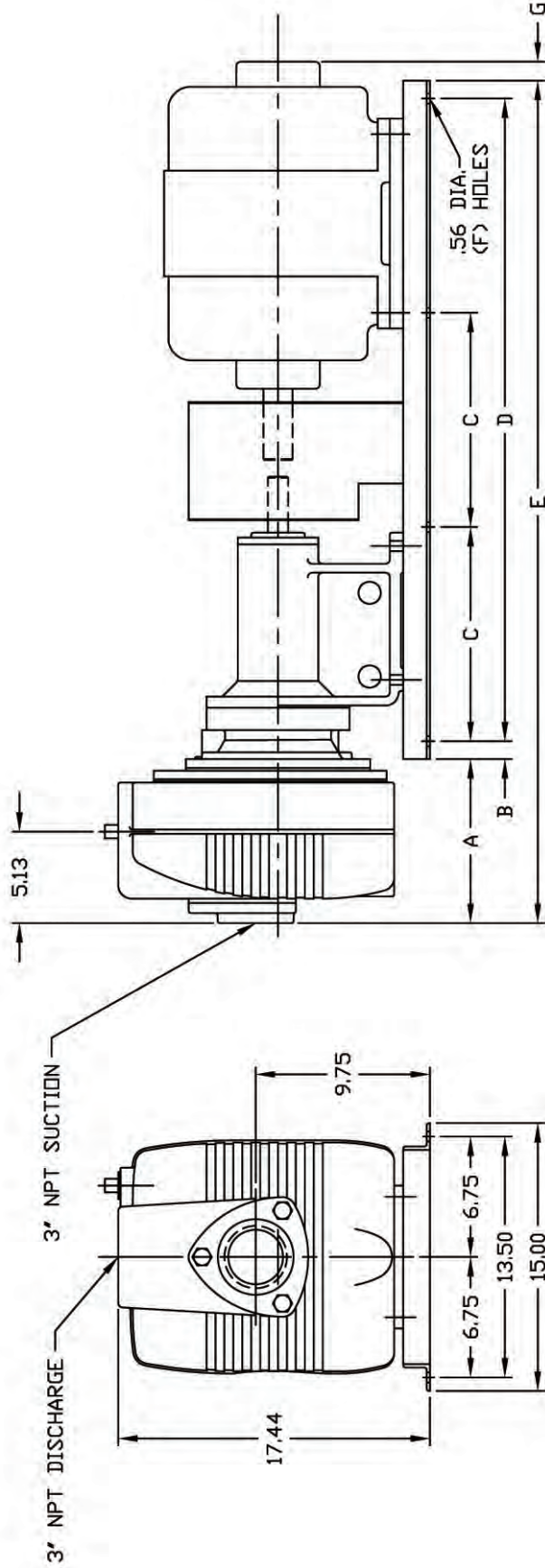

CRANE PUMPS & SYSTEMS			
BURKS PUMPS • BARNES • PROSSER/EMPO • WERNAN • DOBING			
OUTLINE, 151CU-201CU-251CU FLEX-CPLD, 143-256T MOTOR FRAMES			
SIZE	CAGE NO	DWG NO	
B	96046	066355	
SCALE	1=6	FILE	066355
		SHEET	1 OF 1

REVISIONS

REV	DESCRIPTION	DATE	APPROVED
A	RELEASE	5-12-97	JAC
B	00627-98 ADDED 15ICU-20ICU	7-1-98	

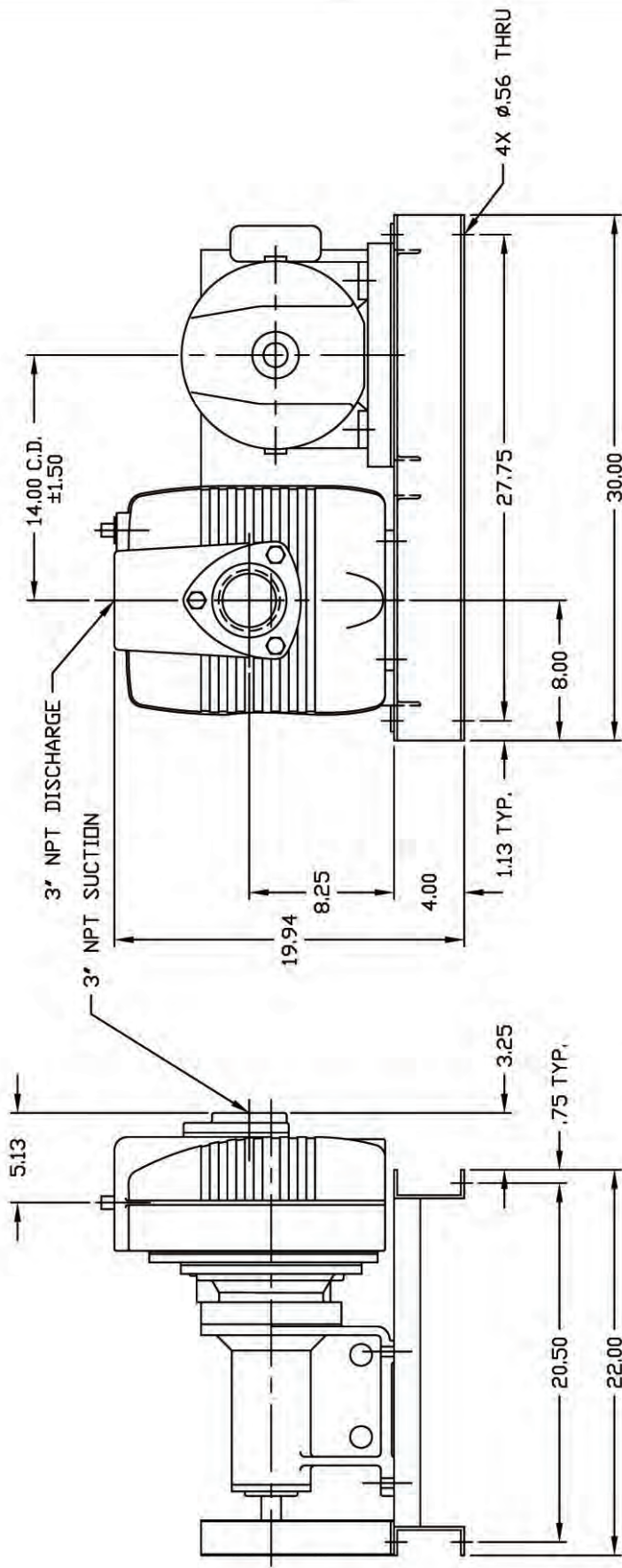

CRANE PUMPS & SYSTEMS  
 BURGESS PUMPS • BARNES • PROSSER/ENPO • NEWMAN • DOWNS

OUTLINE, 15ICU-20ICU-25ICU  
 V-BELT DRIVE, 182-215T

SIZE	CAGE NO	DWG NO	101356
B	96046	FILE	101356
SCALE	1=6	SHEET	1 OF 1



REVISIONS		
REV	DESCRIPTION	DATE
A		6/24/93

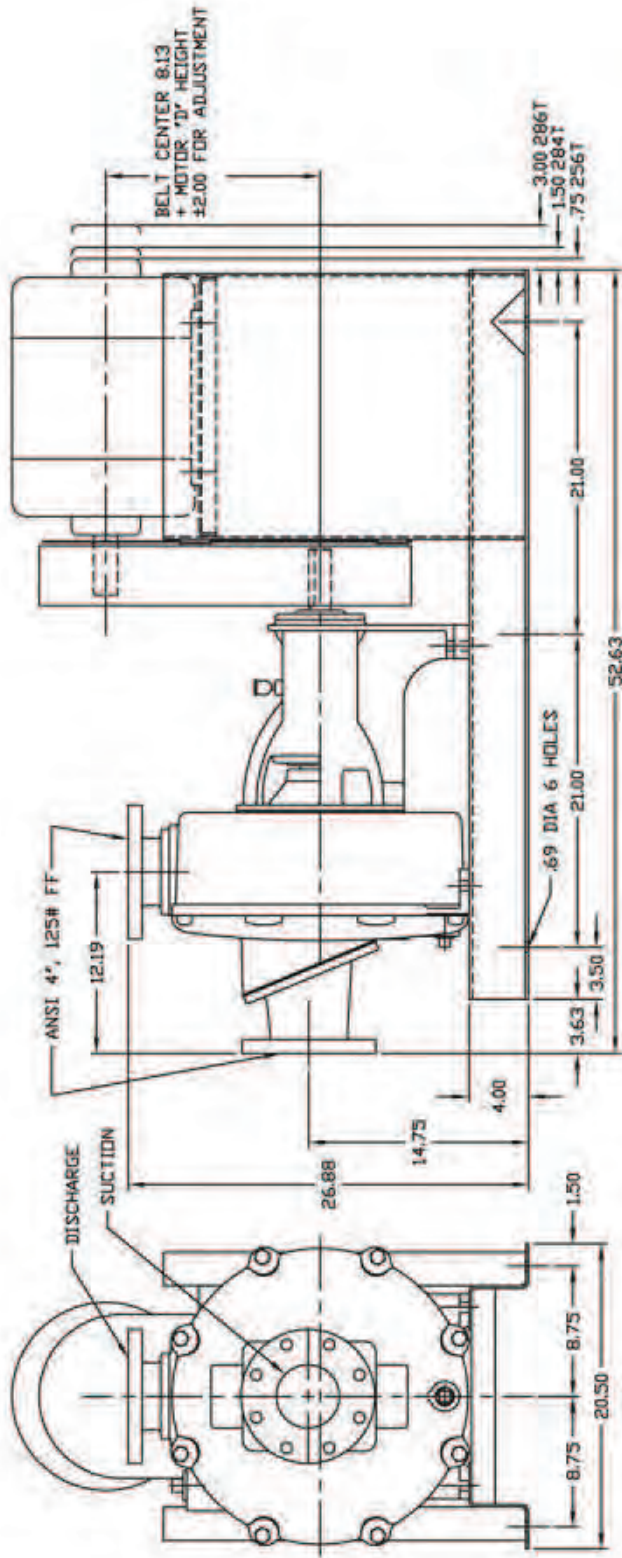

NOTE: ALL DIMENSIONS ARE ±.13.

CRANE	PUMPS & SYSTEMS
REV NO	96046
REV NO	550-00021
SCALE	1:6
FILE	04075
SHEET	1 OF 1

REVISIONS		
REV	DESCRIPTION	DATE
A		6/29/93

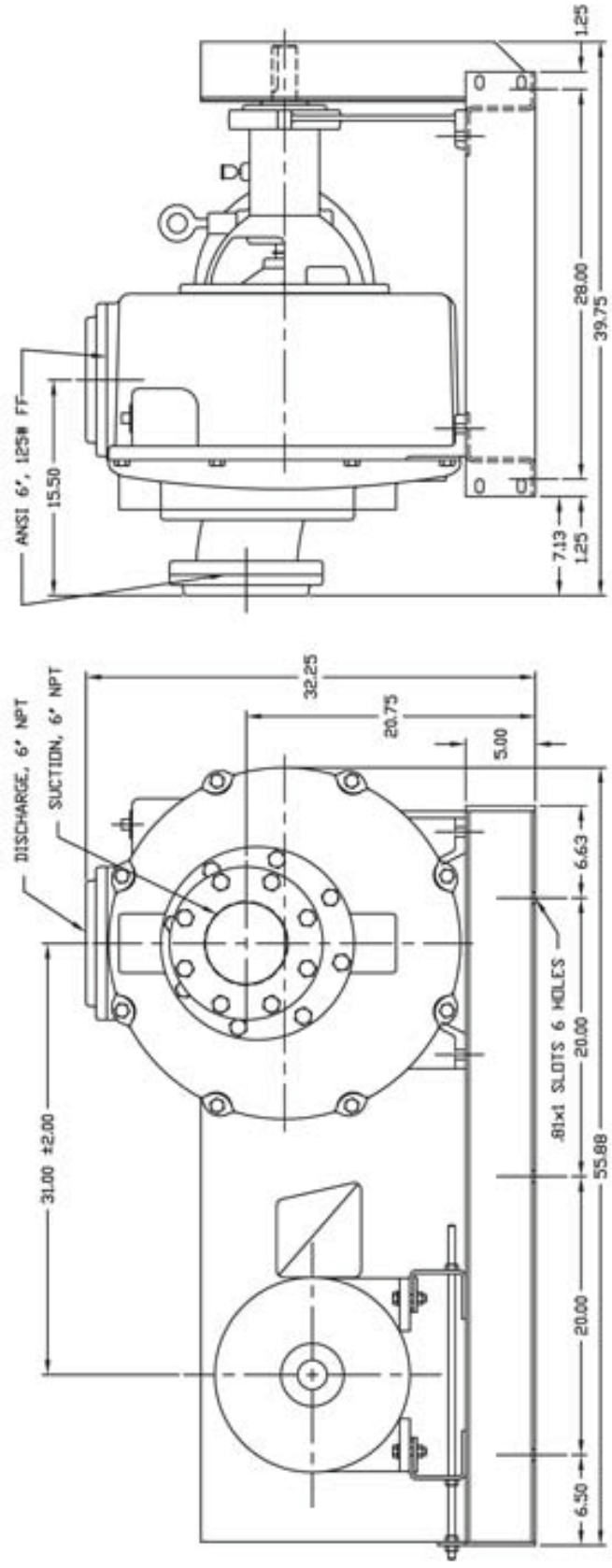

CRANE	PUMPS & SYSTEMS
DATE	6/29/93
REV	A
B60 L.H. V-BELT	
FILE	96046
SCALE	1:4
DRW NO	550-01006
DATE	04/78
SHEET	1 OF 1



4 3 2 1

D C B A

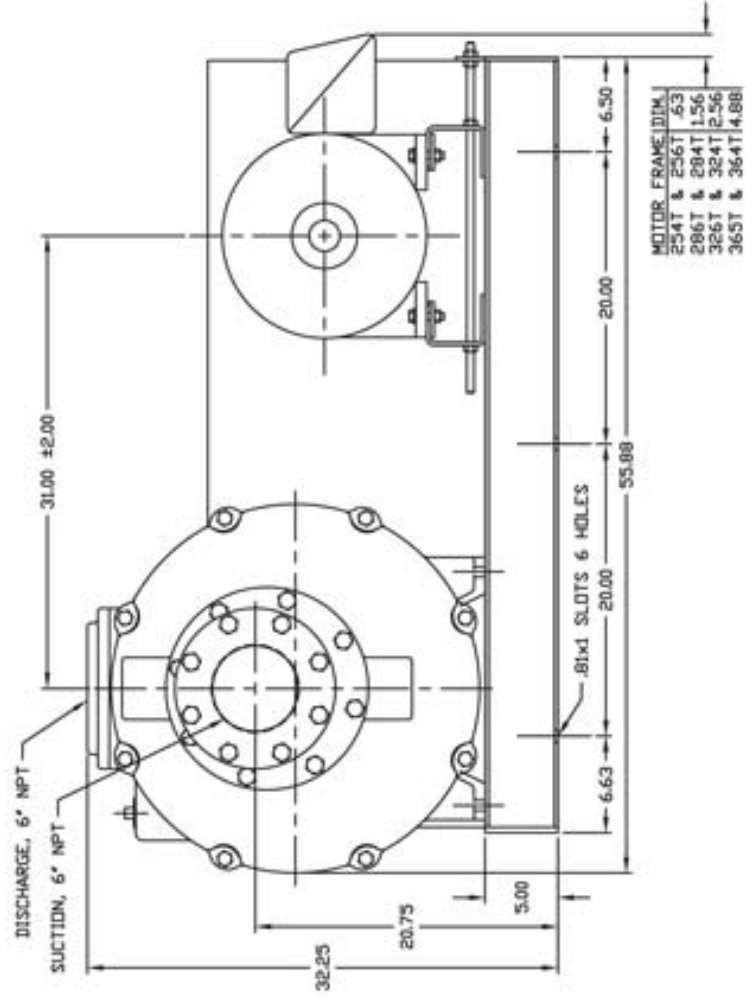
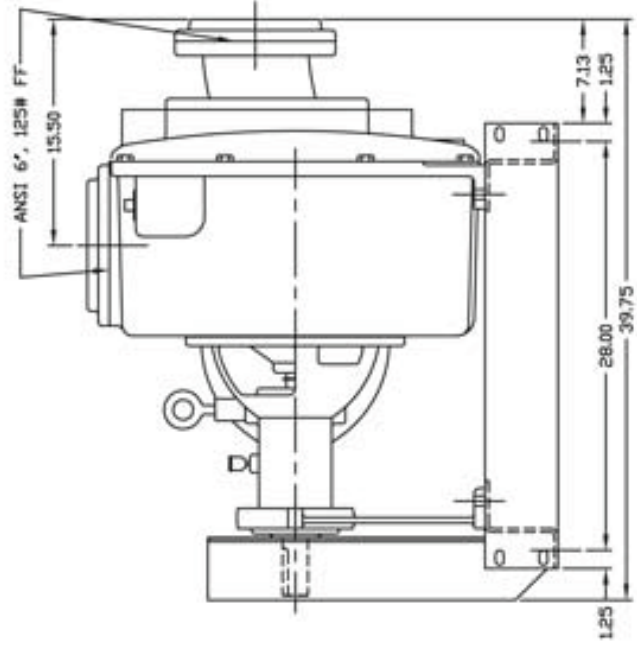

<p>THIS PRINT IS AND CONTAINS PROPRIETARY INFORMATION OWNED EXCLUSIVELY BY CRANE PUMPS &amp; SYSTEMS, INC. THIS RESTRICTION INCLUDES, BUT IS NOT LIMITED TO THE CONDITION THAT THIS PRINT WILL ONLY BE USED AS A RECORD OR TO IDENTIFY OR INSPECT PARTS OR FOR OTHER INFORMATION PURPOSES, AND WILL NOT BE USED TO MANUFACTURE OR PROCURE THE MANUFACTURE OF THE PARTS SHOWN IN THIS PRINT BY ANY OTHER SOURCE THAN CRANE PUMPS &amp; SYSTEMS, INC.</p>	<p>THIS DRAWING IS APPROVED FOR UNCONTROLLED DISTRIBUTION</p>		<p>TITLE</p> <p><b>B60 R.H. V-BELT</b></p>	<p>DWG NO</p> <p><b>550-01007</b></p>	<p>REV</p> <p><b>A</b></p>	<p>DRAWING NO</p> <p><b>96046</b></p>
	<p>WWW.BARNESPUMPS.COM</p>		<p>CRANE</p>	<p>PUMPS &amp; SYSTEMS</p>	<p><b>BARNES®</b></p>	<p>1 OF 1</p>

4 3 2 1

REVISIONS		
REV	DESCRIPTION	DATE
A		6/28/93

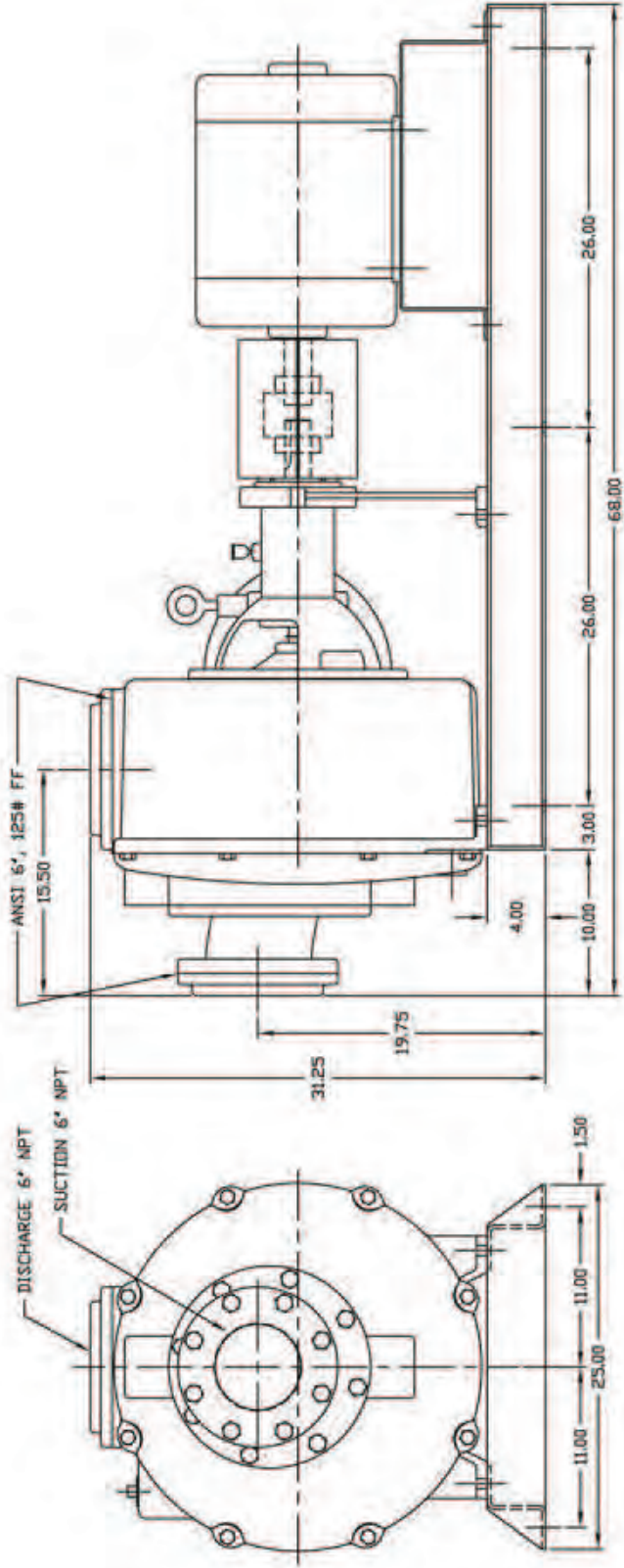

NOTE: ALL DIMENSIONS ARE ±.13

CRANE	PUMPS & SYSTEMS
BRAND NAME	WILLIAMS
B60 FLEX COUPLING	
SIZE	96046
C	96046
SCALE	1:1
FILE	04076
REV. NO.	550-01008
SHEET	1 OF 1

REVISIONS		
REV	DESCRIPTION	DATE APPROVED
A		6/16/93

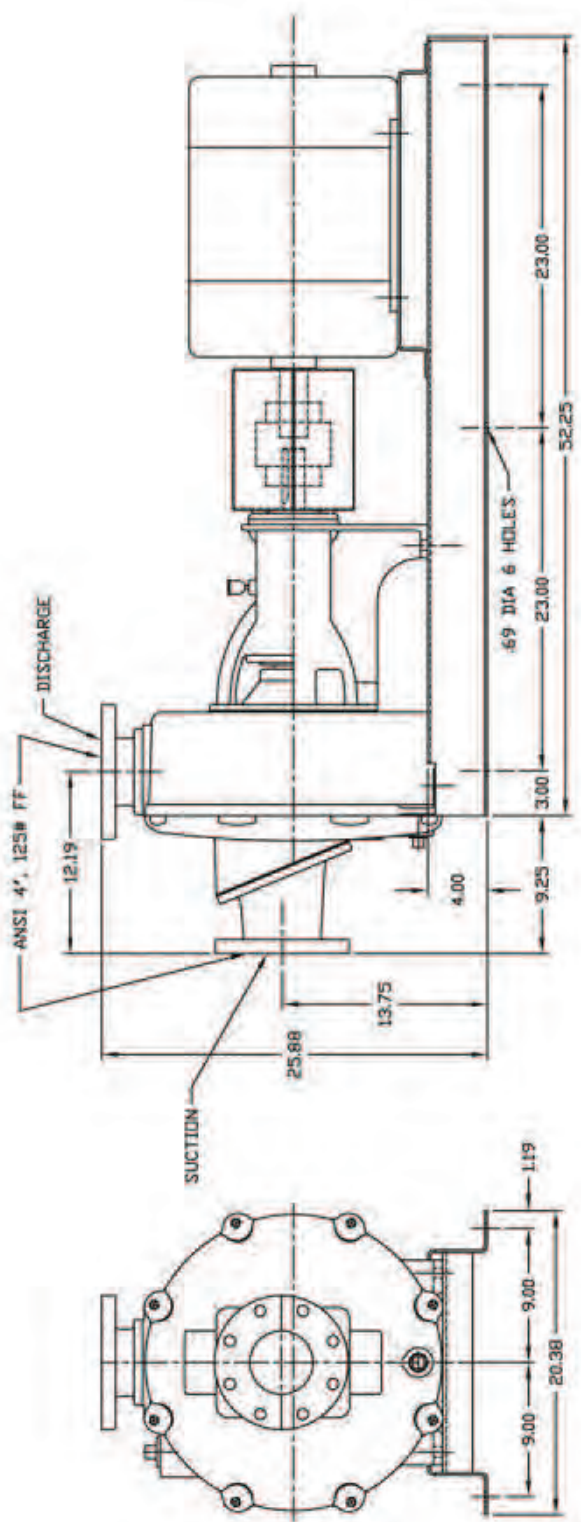

CRANE	PUMPS & SYSTEMS
REV. DATE	REV. DATE
B40 FLEX COUPLING	
SIZE	DWG. NO.
C	96046
SCALE	FILE
1:6	04071
SHEET	1 OF 1

REVISIONS		
REV	DESCRIPTION	DATE APPROVED
A		6/16/93

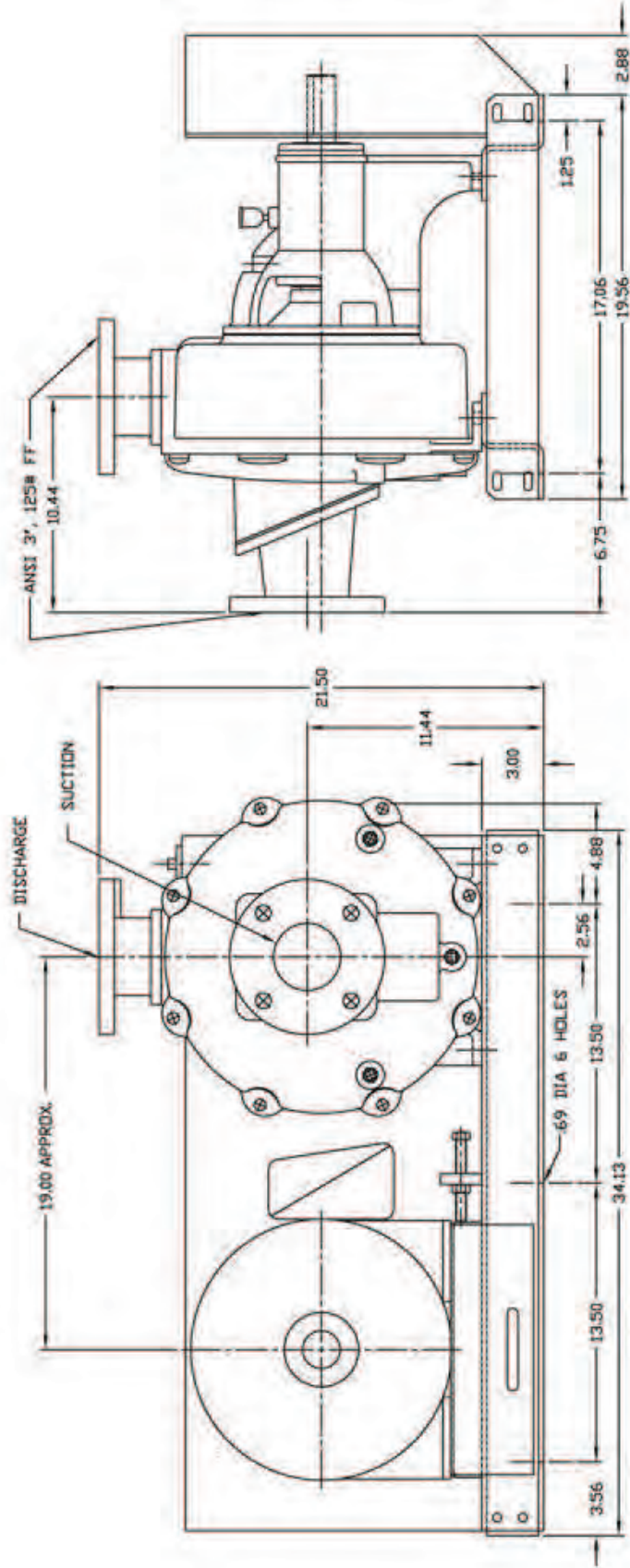

NOTE: ALL DIMENSIONS ARE ±.13.

CRANE	PUMPS & SYSTEMS
REVISED BY	REVISED DATE
B30 L.H. V-BELT	
SIZE	DATE
C	96046
NO. OF SHEETS	550-01018
NO. OF SHEETS	04070
NO. OF SHEETS	1 OF 1



REVISIONS		
REV	DESCRIPTION	DATE
A		6/16/93

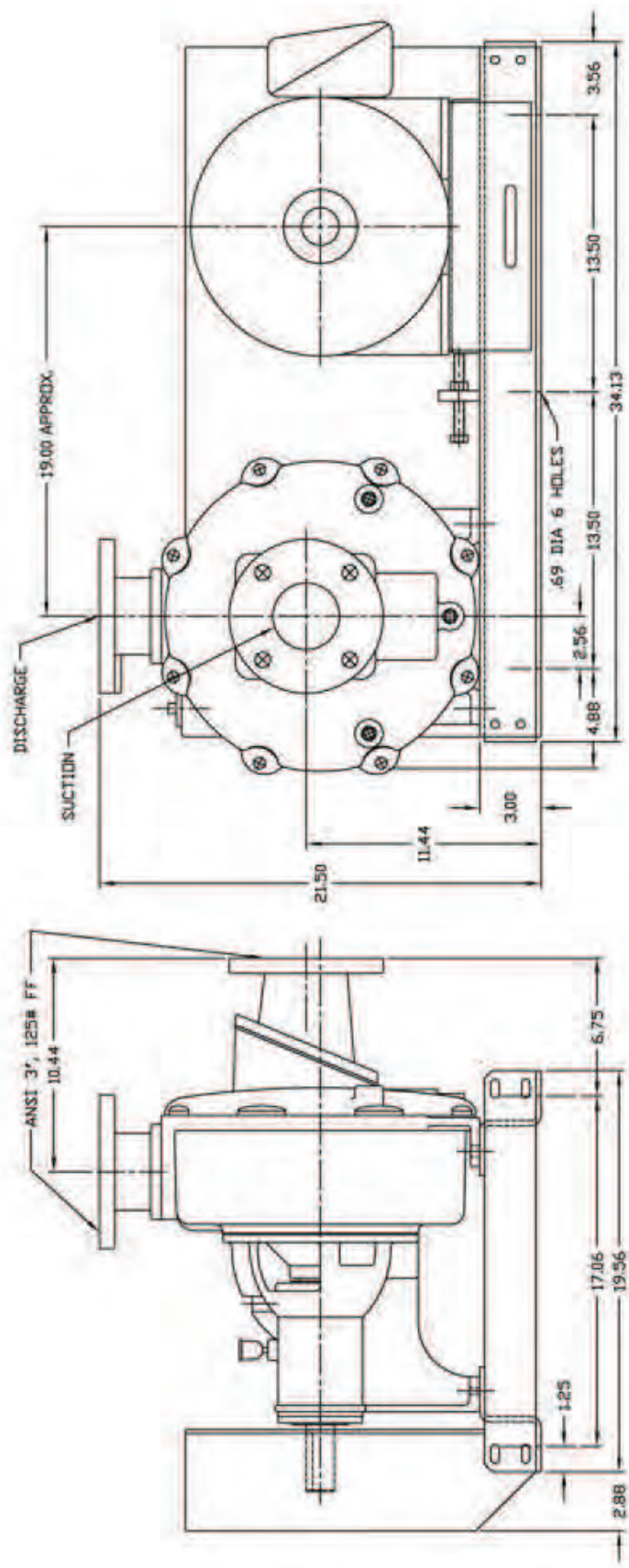

NOTE: ALL DIMENSIONS ARE 4.13.

CRANE	PUMPS & SYSTEMS
96046	B30 R.H. V-BELT
96046	550-01019
1-4	04069
C	1

REVISIONS		
REV	DESCRIPTION	DATE
B		6/4/13

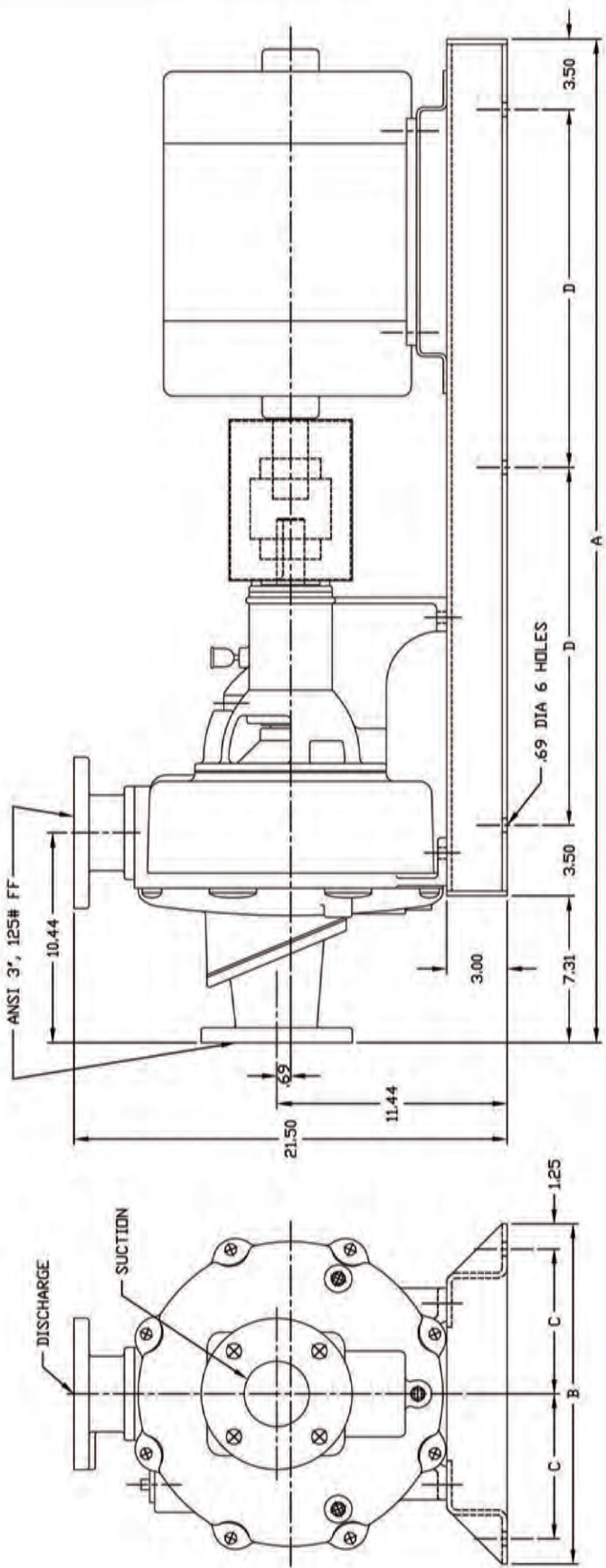

MOTOR FRAME	A	B	C	D
254T-256T	49.81	16.88	7.19	17.75
182T-215T	44.31	16.50	7.00	15.00

NOTE: ALL DIMENSIONS ARE ±.13.

CRANE	PUMPS & SYSTEMS
BONE PUMPS • BONES • PUMPS/PSPS • BOMAN • BOMAS	
SIZE	DWG NO
C	96046
SCALE	FILE
1=4	550-01023
	SHEET
	1 OF 1

B30 FLEX COUPLING

REVISIONS		
REV	DESCRIPTION	DATE APPROVED
A		6/15/93

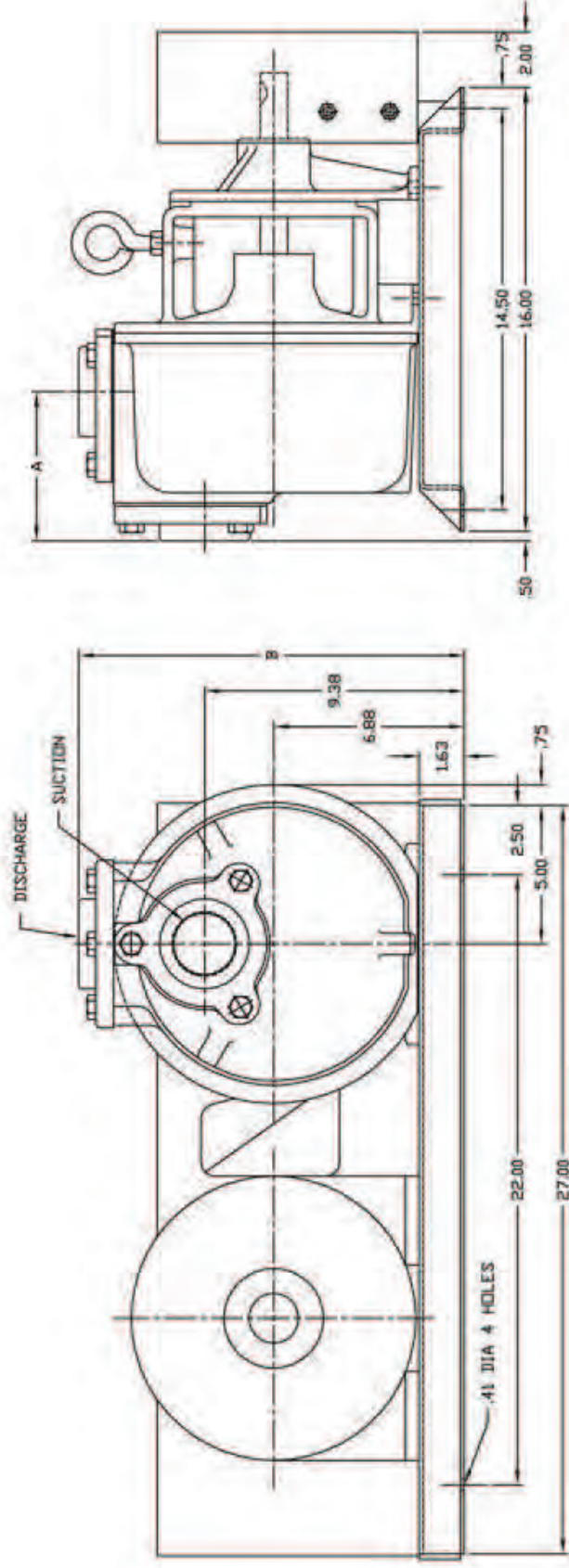

MODEL	A	B	SUCTION	DISCHARGE
B12, B17	5.38	13.88	2" NPT	2" NPT
B19, B21	6.25	14.75	3" NPT	3" NPT

NOTE: ALL DIMENSIONS ARE ±.13.

CRANE	PUMPS & SYSTEMS
B12-B21 L.H. V-BELT	
SIZE	96046
C	550-01044
SCALE	1:3
FILE	04067
SHEET	1 OF 1



REVISIONS		
REV	DESCRIPTION	DATE
A		6/15/93

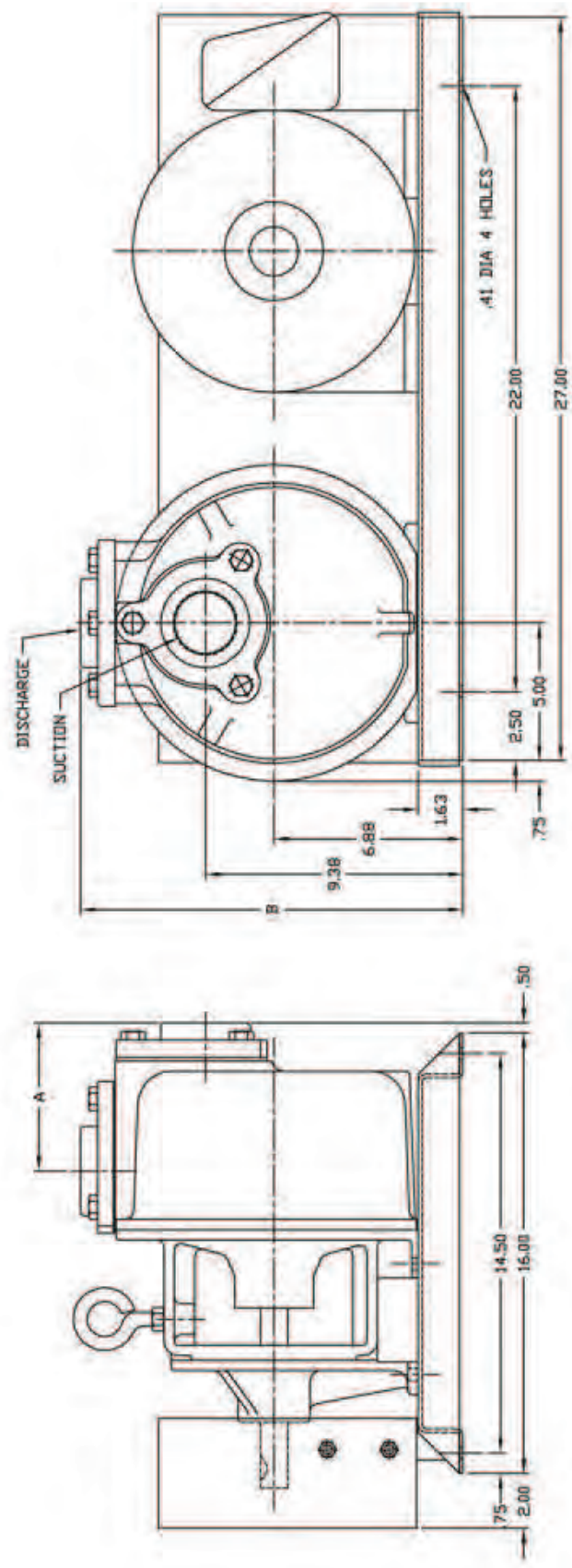

MODEL	A	B	SUCTION	DISCHARGE
B12, B17	5.38	13.88	2" NPT	2" NPT
B19, B21	6.25	14.75	3" NPT	3" NPT

NOTE: ALL DIMENSIONS ARE ±.13.

CRANE	PUMPS & SYSTEMS
1100 1100	1100 1100
B12-B21 R.H. V-BELT	
SIZE	FIG. NO.
C	550-01045
DATE	REV.
1-3	04066
	SHEET
	1 OF 1



REVISIONS		
REV	DESCRIPTION	DATE
A		5/14/93

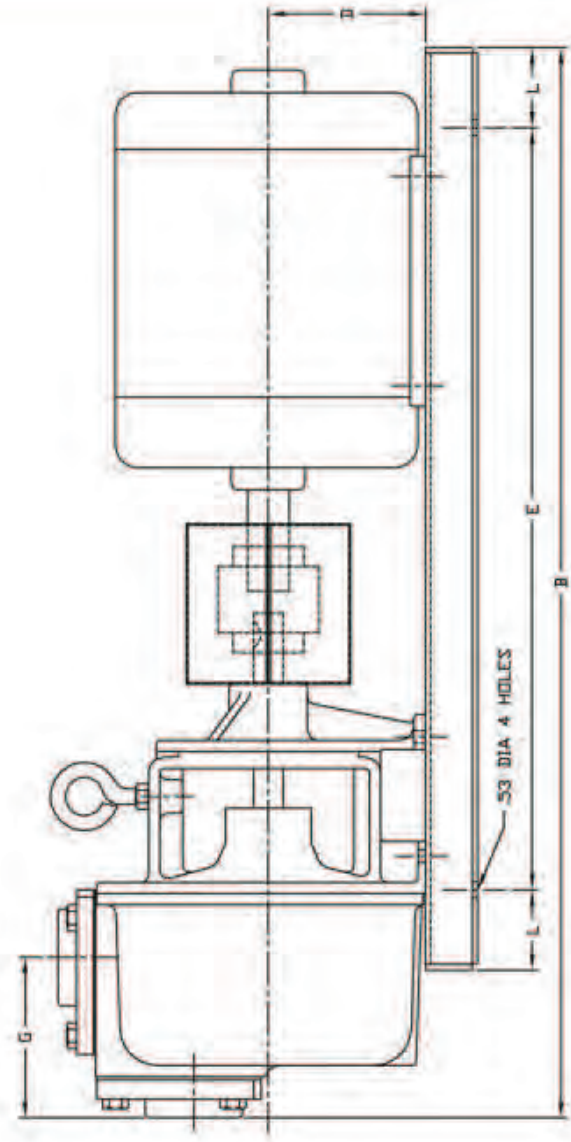
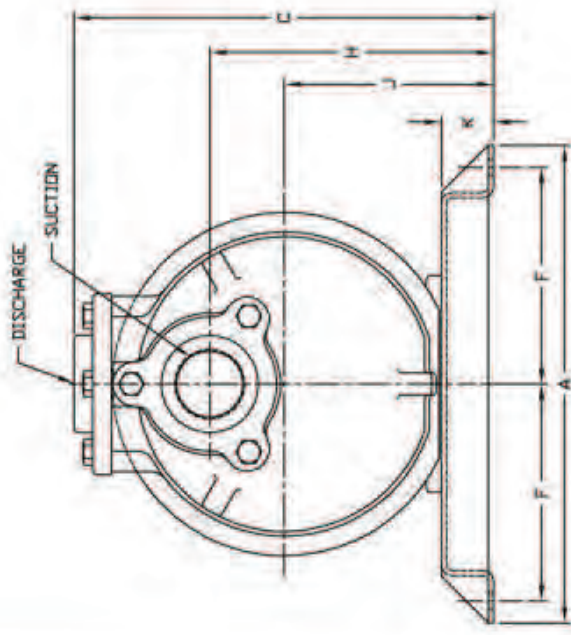

MODEL	SUCTION	DISCHARGE	MOTOR	R.P.M.	A	B	C	D	E	F	G	H	J	K	L
B12.B47	2" NPT	2" NPT	215T	3450	16.00	35.88	14.00	5.25	25.50	7.25	5.38	9.50	7.00	1.75	2.69
B12.B47	2" NPT	2" NPT	143T-182T	1750	16.00	33.13	14.00	5.25	23.00	7.25	5.38	9.50	7.00	1.75	2.50
B19.B21	3" NPT	3" NPT	215T	3450	16.00	36.75	14.88	5.25	25.50	7.25	6.25	9.50	7.00	1.75	2.69
B19.B21	3" NPT	3" NPT	143T-182T	1750	16.00	34.00	14.88	5.25	23.00	7.25	6.25	9.50	7.00	1.75	2.50

NOTE: ALL DIMENSIONS ARE ±.13

CRANE	PUMPS & SYSTEMS
DATE	5/14/93
REV	A
SCALE	1:3
FILE	04063
SHEET	1 OF 1

B12-B21 FLEX COUPLING

SIZE C  
 CRANE NO. 96046  
 PWD NO. 550-01047

REVISIONS		
REV	DESCRIPTION	DATE
A		5/11/93

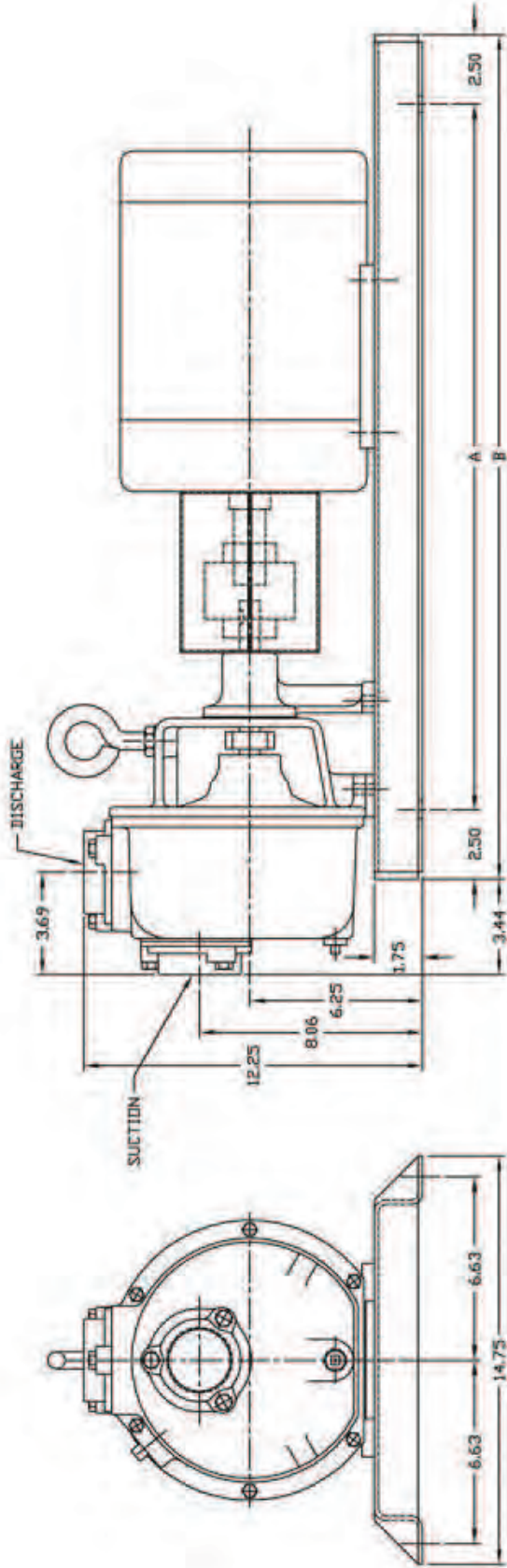

SUCTION	DISCHARGE	MOTOR FRAME	A	B
B4	1.50" NPT	145T-184T	21.00	25.00
B6	1.50" NPT	213T-215T	26.50	30.50
B9	2.00" NPT			

NOTE: ALL DIMENSIONS ARE ±.13.

CRANE		PUMPS & SYSTEMS	
DATE	SIZE	FILE	DWG NO.
C	96046		550-01052
SCALE: 1-3		FILE: D4062	SHEET: 1 OF 1

B4, B6, B9, FLEX COUPLING

REVISIONS		
REV	DESCRIPTION	DATE
1		8/11/93
APPROVED		

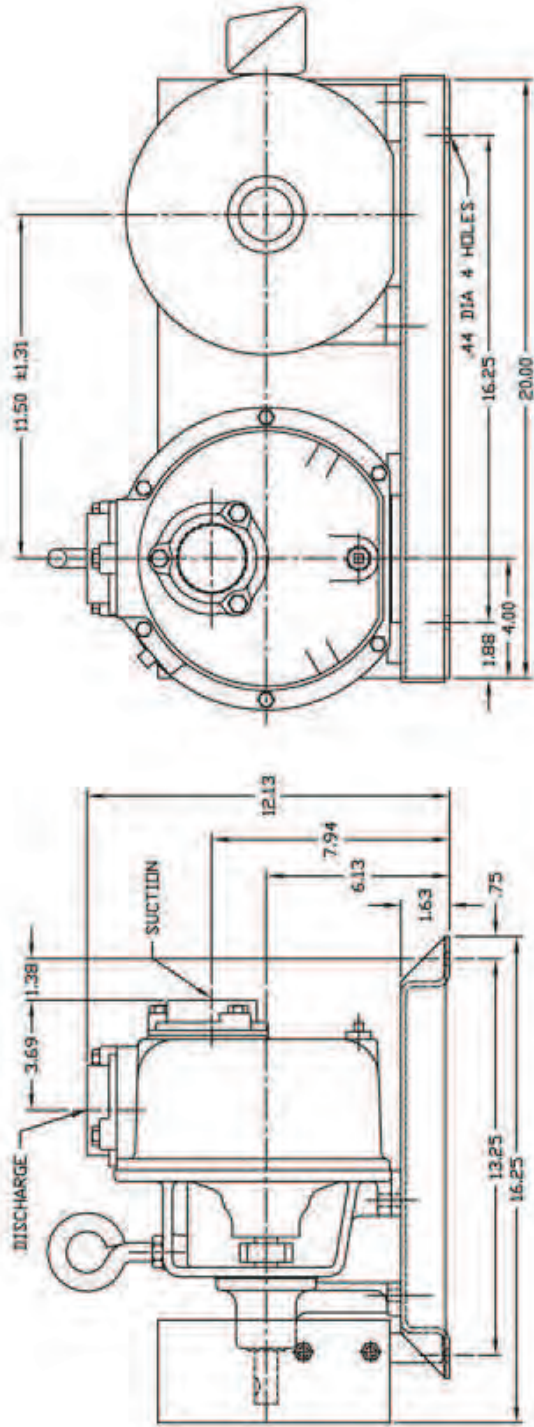

SUCTION DISCHARGE	
B4	1.50" NPT 1.50" NPT
B6	1.50" NPT 1.50" NPT
B9	2.00" NPT 2.00" NPT

NOTE: ALL DIMENSIONS ARE ±.13.

CRANE PUMPS & SYSTEMS	
MODEL NAME	DESIGNATION
B4, B6, B9, R.H. V-BELT	
DATE: 9/6/96	REV: 01
SCALE: 1:3	DRAWING NO: 550-01055
	SHEET: 04063
	OF: 1



REVISIONS		
REV #	DESCRIPTION	DATE
1		6/14/93

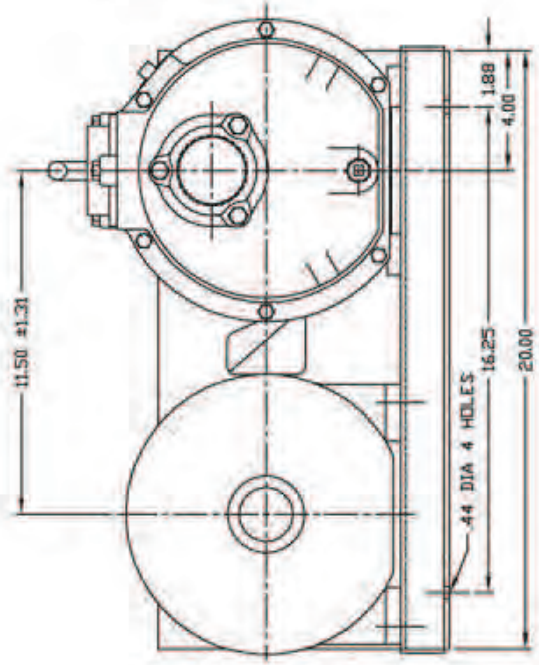
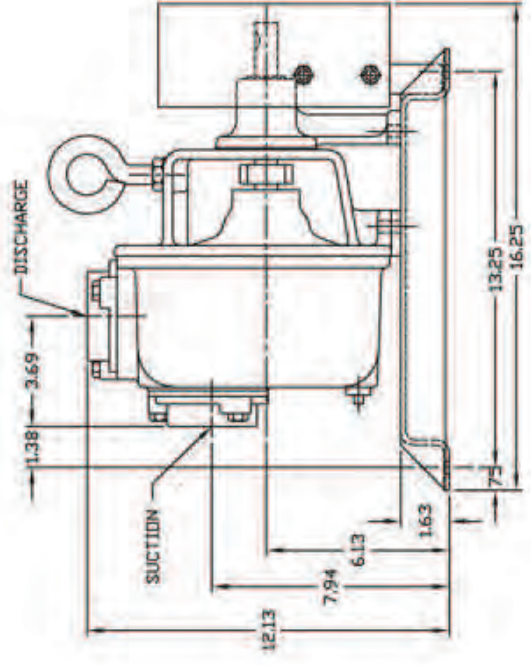

SUCTION DISCHARGE	
B4	1.50" NPT   1.50" NPT
B6	1.50" NPT   1.50" NPT
B9	2.00" NPT   2.00" NPT

NOTE: ALL DIMENSIONS ARE ±.13.

CRANE	PUMPS & SYSTEMS
B4, B6, B9, L.H. V-BELT	
SIZE C	96046
REV 1-3	REV 04064
PAGE 1	SHEET 1 OF 1

REVISIONS		
REV	DESCRIPTION	DATE
1		6/18/93

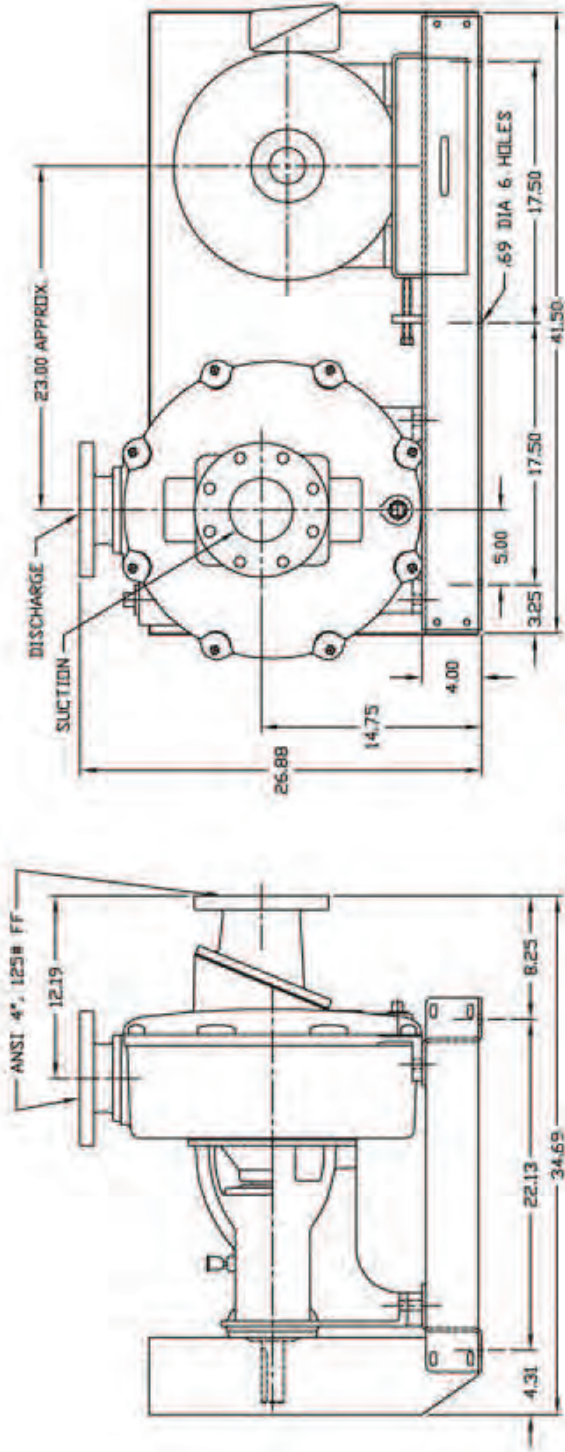

NOTE: ALL DIMENSIONS ARE ±.13.

CRANE	PUMPS & SYSTEMS
96046	BELT
B40 R.H. V-BELT	
96046	550-01057
1-45	04072
SCALE	1.00

REVISIONS		
REV #	DESCRIPTION	DATE APPROVED

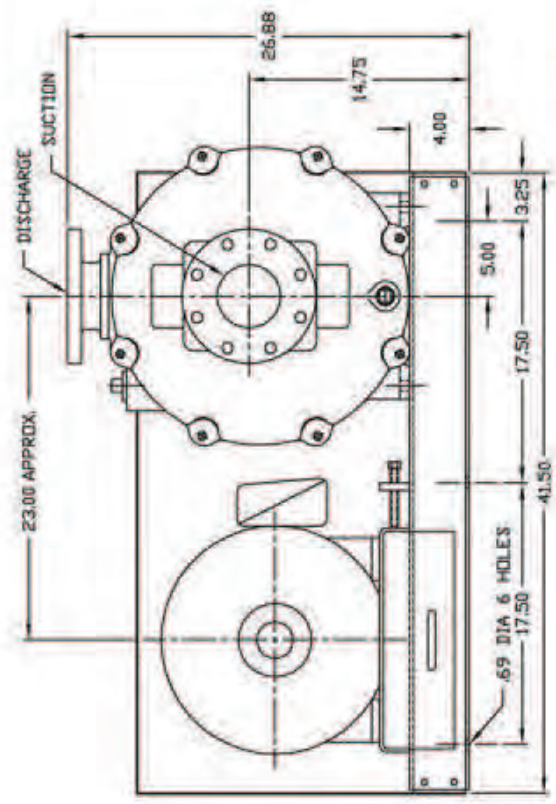
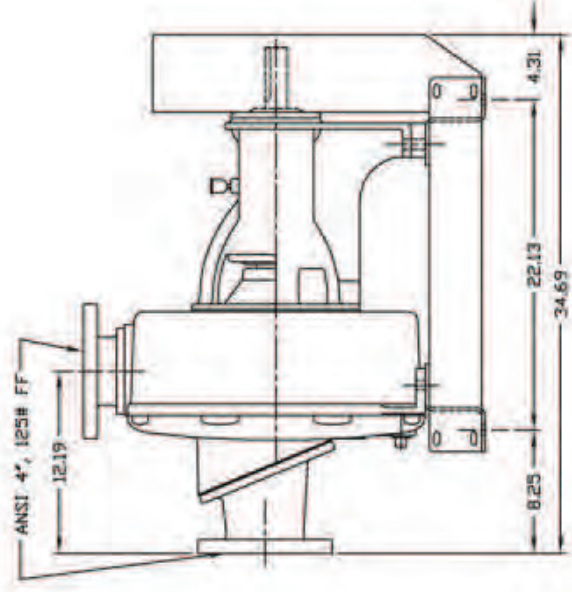

NOTE: ALL DIMENSIONS ARE ±.13.

CRANE	PUMPS & SYSTEMS	REV. NO.	550-01058
DATE	6/7/73	REV.	04073
SIZE	C	REV.	1 OF 1
B40 L.H. V-BELT			

4 3 2 1

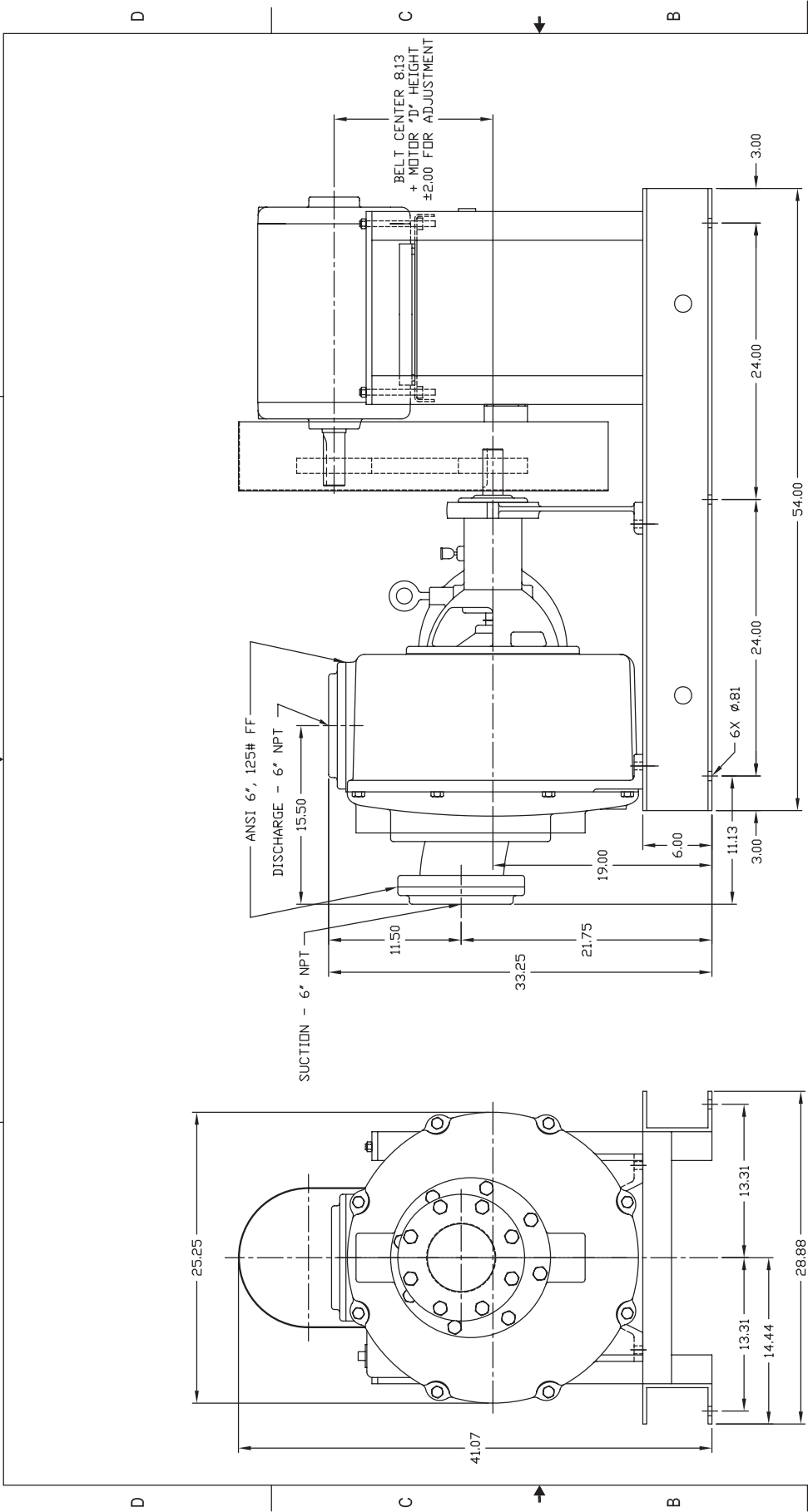

NOTE: ALL DIMENSIONS ARE ±.13.

<p>THIS PRINT IS AND CONTAINS PROPRIETARY INFORMATION OWNED EXCLUSIVELY BY CRANE PUMPS &amp; SYSTEMS, INC. THIS RESTRICTION INCLUDES, BUT IS NOT LIMITED TO THE CONDITION THAT THIS PRINT WILL ONLY BE USED AS A RECORD OR TO IDENTIFY OR INSPECT PARTS OR FOR OTHER INFORMATION PURPOSES, AND WILL NOT BE USED TO MANUFACTURE OR PROCURE THE MANUFACTURE OF THE PARTS SHOWN IN THIS PRINT BY ANY OTHER SOURCE THAN CRANE PUMPS &amp; SYSTEMS, INC.</p>	<p>THIS DRAWING IS APPROVED FOR UNCONTROLLED DISTRIBUTION</p>	<p>TITLE</p> <p><b>B60, VERTICAL V-BELT, 213-286T MOTOR FRAME</b></p>	<p>CAGE NO</p> <p><b>96046</b></p>
	<p>AS A RESULT OF CRANE PUMPS &amp; SYSTEMS CONSTANT PRODUCT IMPROVEMENT PROGRAM, PRODUCT CHANGES MAY OCCUR. AS SUCH, CRANE PUMPS &amp; SYSTEMS RESERVES THE RIGHT TO CHANGE PRODUCT WITHOUT PRIOR WRITTEN NOTIFICATION</p> <p>WWW.CRANEPUMPS.COM</p>	<p>DWG NO</p> <p><b>550-01067</b></p>	<p>REV</p> <p><b>A</b></p>
<p>1 OF 1</p>	<p>SHEET</p>	<p>CRANE® PUMPS &amp; SYSTEMS</p>	<p>1</p>

4 3 2 1

This page intentionally left blank